



Vuelift
Residential
Elevator

Planning
Guide

 savaria.

IMPORTANT NOTICE

This Planning Guide provides nominal dimensions and specifications useful for the initial planning of a project. Before beginning actual construction, make sure you have the installation (shop) drawings customized with specifications and dimensions for your specific project.

Lift configurations and dimensions are in accordance with our interpretation of the standards set forth by the codes listed on the front cover of this Planning Guide. Please consult Savaria or the authorized Savaria dealer in your area for more specific information pertaining to your project, including any discrepancy between referenced standards and those of any local codes or laws.

The dimensions and specifications in this Planning Guide are subject to change (without notice) due to product enhancements and continually evolving codes and product applications.

Visit our website **www.savaria.com** for the most current Vuelift drawings and dimensions.

Copyright © 2018
Savaria Concord Lifts, Inc.
All rights reserved.

Printed in Canada

Purpose of This Guide

This guide assists architects, contractors, and lift professionals to incorporate the Vuelift Residential Elevator into a residential design. The design and manufacture of the Vuelift Elevator meets the requirements of the following codes and standards:

- ASME A17.1/CSA B44 2000, Section 5.3
- ASME A17.1/CSA B44 2004, Section 5.3
- ASME A17.1 2004, Addendum 2005, Section 5.3
- ASME A17.1/CSA B44 2007, Section 5.3
- ASME A17.1/CSA B44, Addendum 2008, Section 5.3
- ASME A17.1/CSA B44 2010, Section 5.3
- ASME A17.1/CSA B44 2013, Section 5.3
- ASME A17.1/CSA B44 2016, Section 5.3
- ASME A17.1 1996, Part 5

We recommend that you contact your local authority having jurisdiction to ensure that you adhere to all local rules and regulations pertaining to residential elevators.

IMPORTANT: This Planning Guide provides nominal dimensions and specifications useful for the initial planning of a vertical platform lift project. Dimensions and specifications are subject to change without notice due to continually evolving code and product applications.

Before beginning actual construction, please consult Savaria or the authorized Savaria dealer in your area to ensure you receive your site-specific installation drawings with the dimensions and specifications for your project.

Visit our website for the most recent Vuelift drawings and dimensions.

How to Use This Guide

- 1 Determine your client's intended use of the lift.
- 2 Determine the local code requirements.
- 3 Determine the site installation parameters.
- 4 Determine the cab type and hoistway size requirements.
- 5 Plan for electrical requirements.

Revision History of This Guide

December 4, 2017 - Initial release

December 14, 2017 - Added Electrical Requirements section on page 9 (round) and page 25 (octagonal)

January 31, 2018 - Added drawings for Type 2, Octagonal, Glass on pages 38 to 43

March 8, 2018 - Revised Noise Level spec in Specifications tables on pages 6 to 22

March 23, 2018 - Added dimensions for controller box and UPS on pages 21 and 45

March 29, 2018 - Revised drawing on page 42

May 7, 2018 - Added wheelchair plan views on pages 21 and 46

May 14, 2018 - Added notes to wheelchair plan views on pages 21 and 46

May 16, 2018 - Added note on pages 22 and 47 stating that a remote controller cannot be more than 50 feet away from the top of the unit in order for the cable to reach

June 7, 2018 - New front cover

Table of Contents

Chapter 1: Round Elevator (Acrylic)	5
Specifications (Round)	6
Safety First (Round)	8
3 & 5 rule (code prior to 2016)	8
3/4 & 4 rule (code 2016 and after)	8
Electrical Requirements (Round)	9
Provisions By Others (Round)	10
General	10
Dimensions	10
Structural	10
Electrical	10
Entrances	10
Site Preparation (Round)	11
Finished Floors	11
230V Power (with Switched Disconnect)	11
110V Power (with Switched Disconnect)	11
Telephone Works	11
Floor Built for Load	11
Floor and Pit Cutouts Complete	11
Check Floor to Floor Maximum and Minimum Distances	11
Drywall and Painting	11
Load Calculations (Round)	12
Drawings (Round)	13
Chapter 2: Octagonal Elevator (Acrylic or Silica Glass)	22
Specifications (Octagonal)	23
Safety First (Octagonal)	25
3 & 5 rule (code prior to 2016)	25
3/4 & 4 rule (code 2016 and after)	25
Electrical Requirements (Octagonal)	26
Provisions By Others (Octagonal)	27
General	27
Dimensions	27
Structural	27
Electrical	27
Entrances	27
Site Preparation (Octagonal)	28
Finished Floors	28
230V Power (with Switched Disconnect)	28
110V Power (with Switched Disconnect)	28
Telephone Works	28
Floor Built for Load	28
Floor and Pit Cutouts Complete	28
Check Floor to Floor Maximum and Minimum Distances	28
Drywall and Painting	28
Load Calculations (Octagonal Acrylic)	29
Load Calculations (Octagonal Silica Glass)	30
Drawings (Octagonal)	31

Chapter 1: Round Elevator (Acrylic)



Specifications (Round)

Specification	Specification Data
Load capacity	840 lb (381 kg)
Maximum travel	42.5 ft (12.95 m)
Travel speed	32 ft/min (0.16 m/s)
Noise level (for typical installation)	65 dB
Daily cycle	Normal: 40 Heavy: 80 Excessive: 150 Maximum starts in 1 hour on standard installation: 20 NOTE: Please consult your Sales Representative if there's a chance you may exceed these amounts.
Maximum levels serviced	6
Minimum overhead	106" (2692 mm) for standard cab 96" (2438 mm) for short cab
Cab	Cab walls: Full clear acrylic Cab interior height (standard): 84 in (2.13 m) Cab interior height (optional): 76.5 in (1.94 m) Cab weight: 550 lb (250 kg) Cab floor area: 13.09 sq ft (1.22 sq m)
Footprint	54" diameter (1.37 m)
Power supply	30A, 230-V, single-phase, 50/60 Hz
Cab lighting	15A, 115V, single-phase, 50/60 Hz
Suspension	Type: Galvanized aircraft cable (2 x 3/8" diameter) Construction: IWRC 7 x 19 RHRL Nominal strength: 14,400 lb (6,545 kg) Weight of ropes: 0.243 lb/ft (3.616 g/cm) Travel cable weight: 0.228 lb/ft (3.393 g/cm)
Drive train	Type: Winding drum Motor: 1.5 HP with integrated brake Transmission: Ultra-low vibration, 3-stage, right-angle, helical-bevel drive Motor control: Preprogrammed variable frequency drive Door interlocks: Honeywell RDI-G-L5B certified (compliant with ASME A17.1 Section 2.12.4.3)
Pit/floor load	Refer to the section "Load Calculations"
Distance between 2 landings	93" (2362 mm) minimum
Pit depth	4" - 12" (102 mm- 305 mm) No pit with optional short ramp
Temperature	-10 °C to +40 °C (14 °F to 104 °F)
Safety features	Pit run/stop switch and car top run/stop switch Emergency stop switch Safety brakes Overspeed governor Manual lowering Emergency battery back-up for cab lighting and lowering

Specification	Specification Data
Options	Optional configurations: Type 1, 2, 3 Optional colors: <ul style="list-style-type: none">• White (Texture White PX521W859)• Silver (Texture Silver PX521S343)• Custom powder-coat frame Note that Black is the standard color (Texture Black PX622N365) Other options: Up to 6 stops, panoramic car ceiling, balcony attachment

Safety First (Round)

3 & 5 rule (code prior to 2016)

The ASME A17.1/CSA-B44–Safety Code for Elevators and Escalators (**PRIOR TO 2016**) mandates the following maximum hoistway door clearances (see drawing on next page).

- Clearance between the hoistway door and the hoistway edge of the landing sill shall not exceed 3" (76 mm).
- Distance between the hoistway face of the landing door and the car door shall not exceed 5" (127 mm).
- Vuelift Residential Elevator design is with a maximum 1.25" (32 mm) running clearance.

3/4 & 4 rule (code 2016 and after)

The ASME A17.1-2016/CSA B44-16 Safety Code for Elevators and Escalators (**2016 AND AFTER**) mandates the following maximum hoistway door clearances (see drawing on next page):

- Clearance between the hoistway door and the hoistway edge of the landing sill shall not exceed 0.75" (19 mm).
- Distance between the hoistway face of the landing door and the car door shall not exceed 4" (102 mm).
- Vuelift Residential Elevator design is with a maximum 1.25" (32 mm) running clearance.

Electrical Requirements (Round)

Your electrician and phone installer must supply the following connections:

- Main Disconnect - One 230V single-phase, 30 Amp fused disconnect box with 20 Amp fuse/breaker. If voltage is not 230V minimum, a buck-boost transformer is required.
- Lighting Disconnect - One 120V, 15 Amp fused disconnect or circuit breaker for cab lighting.
- Telephone Line - One telephone line jack is closes proximity to the controller.

NOTE: Savaria does not provide power cable to main disconnect.

Recommended manufacturers for fused disconnect

Square D

- Main disconnect: 230V single-phase disconnect model # H221N.
240V, 30 Amp with Interlock Kit - ELK031 Aux Contacts (normally opened/normally closed).
In addition, two each - 250V, 20 Amp, RK5 fuses.
- Lighting disconnect: 120V, 15 Amp fused disconnect or circuit breaker.

Siemens

- Main disconnect: 230V single-phase disconnect model #HF221N.
240V, 30 Amp with Interlock Kit-HA 161234 Aux Contacts (normally opened/normally closed).
In addition, two each - 250V, 20 Amp, RK5 fuses.
- Lighting disconnect: 120V, 15 Amp fused disconnect or circuit breaker.

G.E.

- Main disconnect: 230V single-phase disconnect model # TH3221.
240V, 30 Amp with Interlock Kit - THAUX21D Aux Contacts (normally opened/normally closed).
In addition, two each - 250V, 20 Amp, RK5 fuses.
- Lighting disconnect - 120V, 15 Amp fused disconnect or circuit breaker.

Cutler Hammer

- Main disconnect: 230V single-phase disconnect model # DH221NGK.
240V, 30 Amp with Interlock Kit - THAUX21D Aux Contacts (normally opened/normally closed).
In addition, two each - 250V, 20 Amp, RK5 fuses.
- Lighting disconnect: 120V, 15 Amp fused disconnect or circuit breaker.

Recommended manufacturers for circuit breakers at the distribution panel (and the distribution panel itself): Square D or Siemens only.

Provisions By Others (Round)

General

Construction Site

The owner/agent is required to provide all masonry, carpentry, and drywall work as required. Floors shall be in a finished state prior to installation of the unit. Refer to the section, Site Preparation on the next page.

Dimensions

The contractor/customer must verify all clearance dimensions prior to delivery of the unit.

Structural Floor Loads

A structural engineer is required to ensure that the building will safely support all loads imposed by the lift equipment. Refer to the tables on the installation drawings (shop drawings) for pit/floor loads imposed by the equipment. Refer to the section, Load Calculations.

Electrical Power Supply

See the following table. Lockable fused disconnects must be installed in compliance with electrical code and are to be provided prior to installation of the unit. Roughed in power to the lift must be provided to the head assembly location prior to installation of the unit.

Power Supply Specifications	Disconnect Size	Time Delay Fuse Size	Volts	Phase
Motor and equipment	30 Amps	30 Amps	230 Volts	Single
Cab lights	15 Amps	15 Amps	115 Volts	Single

Telephone

If a telephone circuit is required, the jack is to be provided and installed by others. This circuit shall be brought to a location next to the controller and be available to connect and test upon elevator installation.

Permanent Power

Before installation can begin, permanent power must be supplied.

Entrances Handrails

All balcony levels require handrails to be installed per local codes after installation is completed. The handrail and installation is to be provided by the contractor/customer. Savaria Concord Lifts Inc. and/or local installer are not responsible for handrail installation or materials.

Site Preparation (Round)

The following items **MUST** be completed prior to installation of the elevator.

Finished Floors

- Finished floors be installed at all landing levels.

230V Power (with Switched Disconnect)

- Permanent 230V, single-phase, 30-Ampere dedicated power to a lockable fused (cartridge type) disconnect switch.
- Disconnect switch must be mounted in a location within line of sight of the elevator or controller.
- 230V source must be run from the disconnect switch to a junction box in a discrete location at the top of the elevator hoistway location.
- Disconnect must be installed according to all applicable local codes.

110V Power (with Switched Disconnect)

- Permanent 110V, single-phase, 15-Ampere dedicated power to a lockable, fused (cartridge type) disconnect switch.
- Disconnect switch must be mounted near the 230V disconnect switch.

Telephone Works

- Telephone jack must be provided next to the electrical disconnects. This can be the common house line in most jurisdictions. Please check with your local installer or building contractor for code requirements.

Floor Built for Load

- Smooth level surface for installing the elevator, with floor load bearing capacity for the elevator plus rated load. An exact specification can be provided by contacting Savaria.

Floor and Pit Cutouts Complete

- If a pit is to be used, a smooth, level surface of at least 4" must be provided. For pit depths greater than 12", contact Savaria to ensure proper equipment will be provided.
- It is recommended that any pit floor and walls be finished prior to installation. Pit floor and walls are visible after elevator installation is completed.
- Hole in floor, or modified balcony rail as directed by drawings.

Check Floor to Floor Maximum and Minimum Distances

- 106" (2692 mm) minimum overhead distance from upper floor level to the underside of the finished ceiling for standard cab configuration.
- 96" (2438 mm) minimum overhead distance from upper floor level to the underside of the finished ceiling for modified short cab configuration.

Drywall and Painting

- All drywall and painting must be complete.

Load Calculations (Round)

- Primary loads are carried by the four support columns that run from top to bottom on the elevator.
- The load (represented below as Lower Floor Total Load) is supported on 4"x4" plates at the bottom of each of the four columns.
- Vuelift elevators are designed such that the dead load and impact load are transferred to the lowest level through the rail base plates and rings when installed properly in a building with structural integrity including consistent floor to floor heights.

Note: Vuelift elevators are designed for applications in buildings that maintain consistent floor to floor height as the building ages.

If floor to floor height changes after installation, the elevator **MUST** be taken out of service pending inspection and correction by a trained installation technician.
- All mid floors including the bottom floor may be subjected to a maximum lateral load of 200 lb.
- Walls of bricks, terra-cotta, hollow blocks, and similar materials shall not be used for attachment of column (guide rail) brackets unless adequately reinforced.
- Where necessary, the building construction shall be reinforced to provide adequate support for the columns (guide rails).
- Shipping weight is estimated actual including crating materials, etc.
- Floor load figures include elevator structure weight when loaded with full test capacity.
- Floor load figures shown here are actual loads; your building engineer must add a proper factor of safety to the floor design.
- Many jurisdictions require floor designs to include at least a safety factor of 2.0, doubling the loads shown here.
- **To reiterate, these figures DO NOT include your factor of safety for floor loads.** Engineer your floor to include (add) an appropriate safety factor and comply with local building codes.

$$\text{Lower Floor Dead Load (lbf)} = (38 \times \text{feet of hoistway}) + (60 \times \text{number of floors}) + 2193$$

$$\text{Lower Floor Impact Load (lbf)} = 3703$$

$$\text{Lower Floor Total Load (lbf)} = \text{Dead Load} + \text{Impact Load}$$

$$\text{Mid Floor Load (lbf)} = 182$$

$$\text{Shipping Weight (lb)} = (694 \times \text{number of floors}) + 1720$$

Note: Shipping weight includes the actual component weights for all parts, plus shipping crate and packaging weight.

Examples

	<u>3 stop with 36' of hoistway</u>	<u>2 stop with 19' hoistway</u>
Lower Floor Dead Load	3,741	3,035
Lower Floor Impact Load	<u>3,703</u>	<u>3,703</u>
Lower Floor Total Load	7,444	6,738
Mid Floor Loads (on each mid floor)	182	182
Shipping Weight	3,802	3,108

Drawings (Round)

- Plan view
- Pit/bottom floor/thru-floor view
- Balcony detail
- Thru-floor detail
- Elevation view
- Provisions by others
- Pit cutout detail
- Wheelchair plan view
- Controller box and UPS dimensions

Figure 1: Plan view (round)

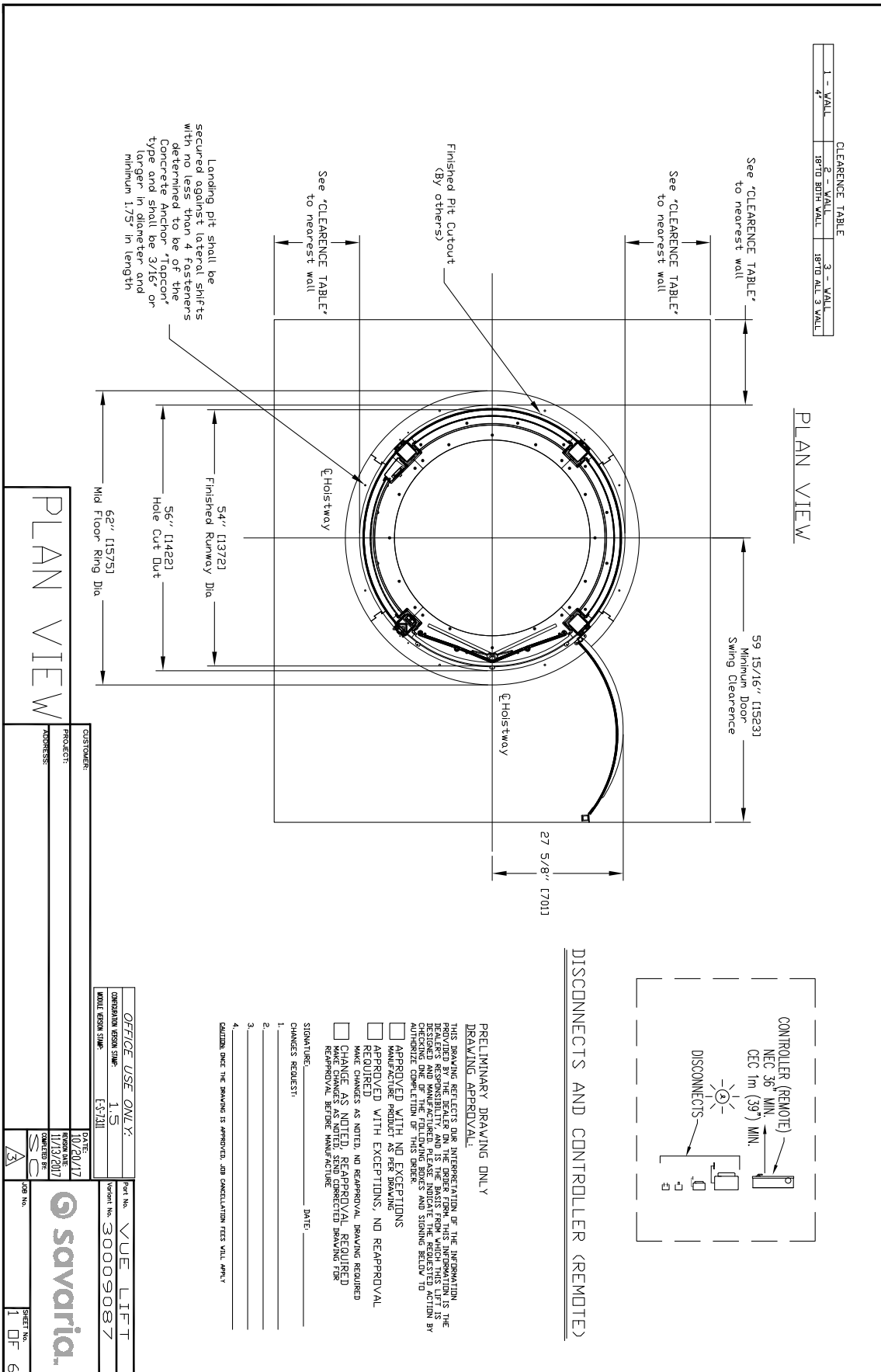
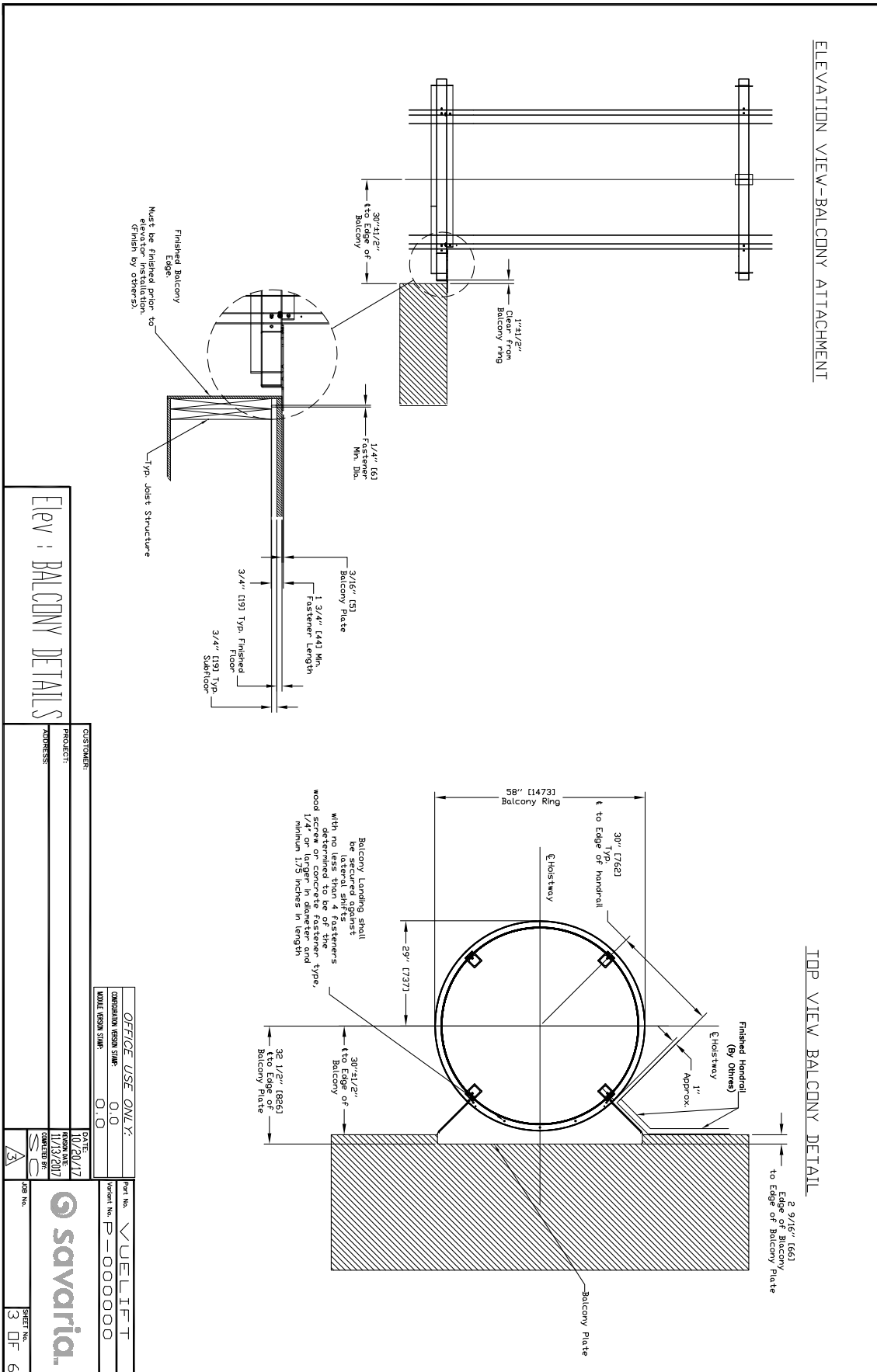

Figure 3: Balcony detail (round)



Rev : BALCONY DETAILS

CUSTOMER:	PROJECT:	DATE:	Part No.
ADDRESS:	ADDRESS:	10/2/2017	VUELIFT
		11/13/2017	Variant No. P-000000
			3 OF 6



Figure 4: Thru-floor detail (round)

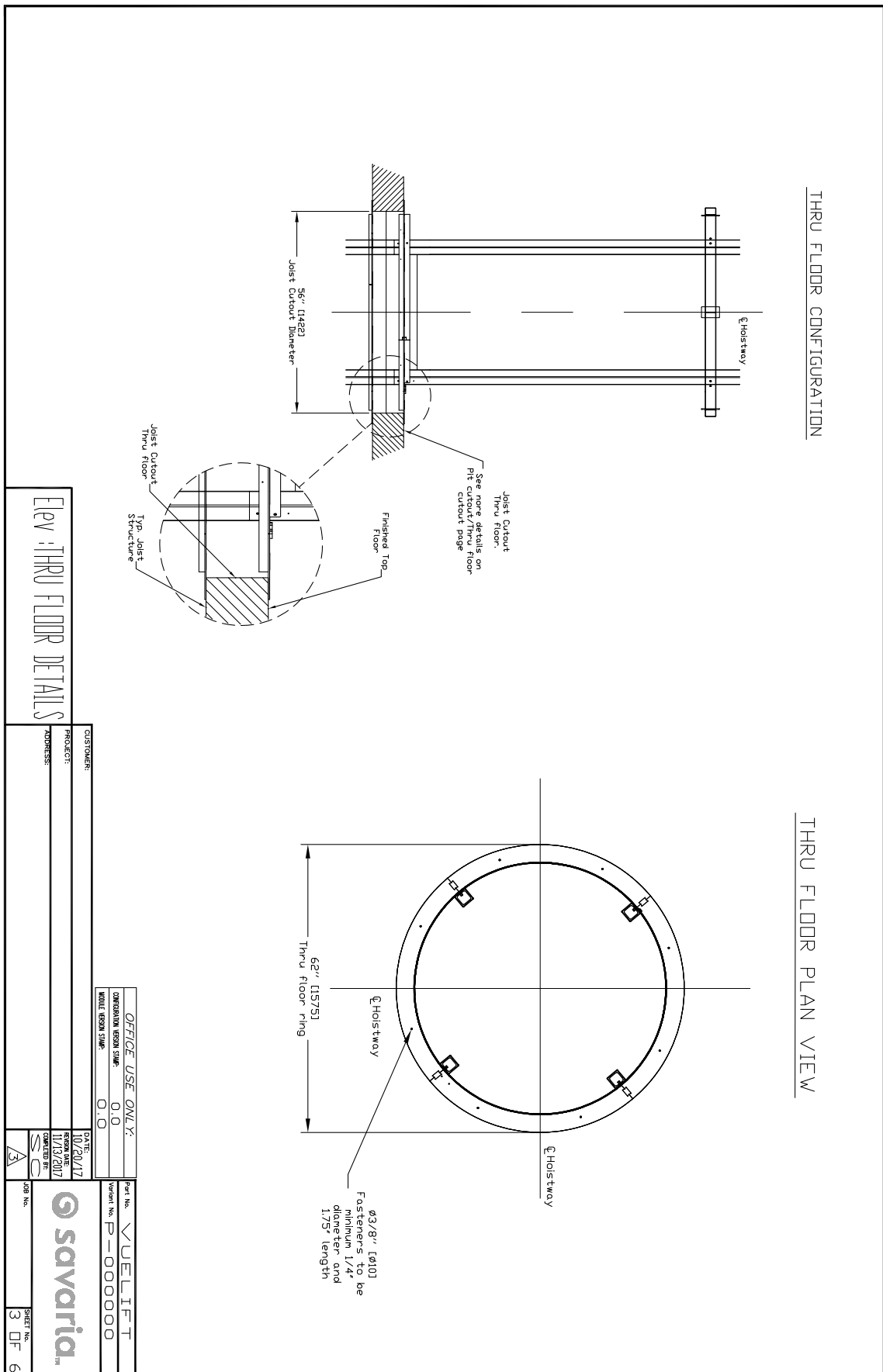

Figure 5: Elevation view (round)

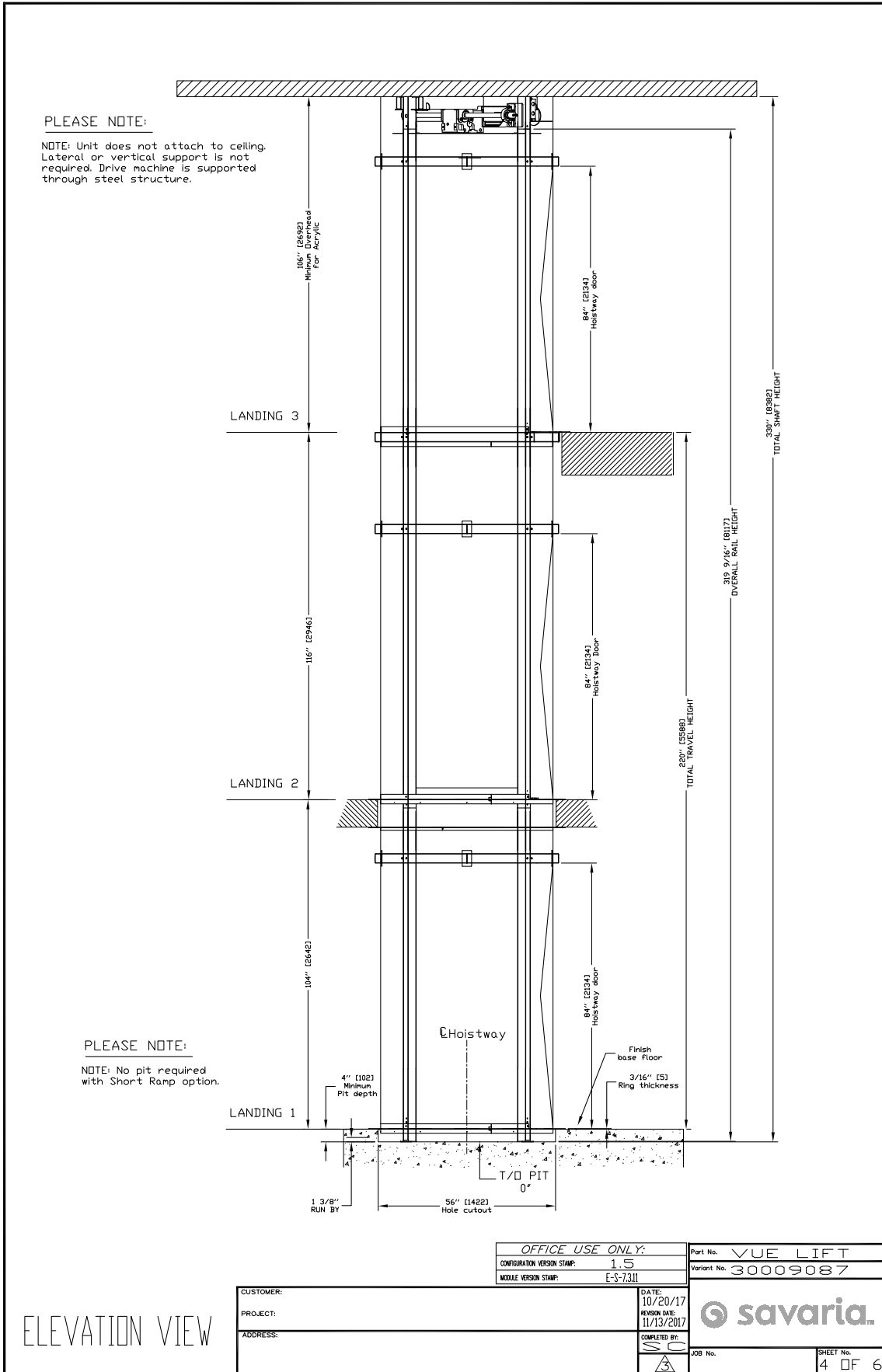

Figure 7: Pit cutout detail (round)

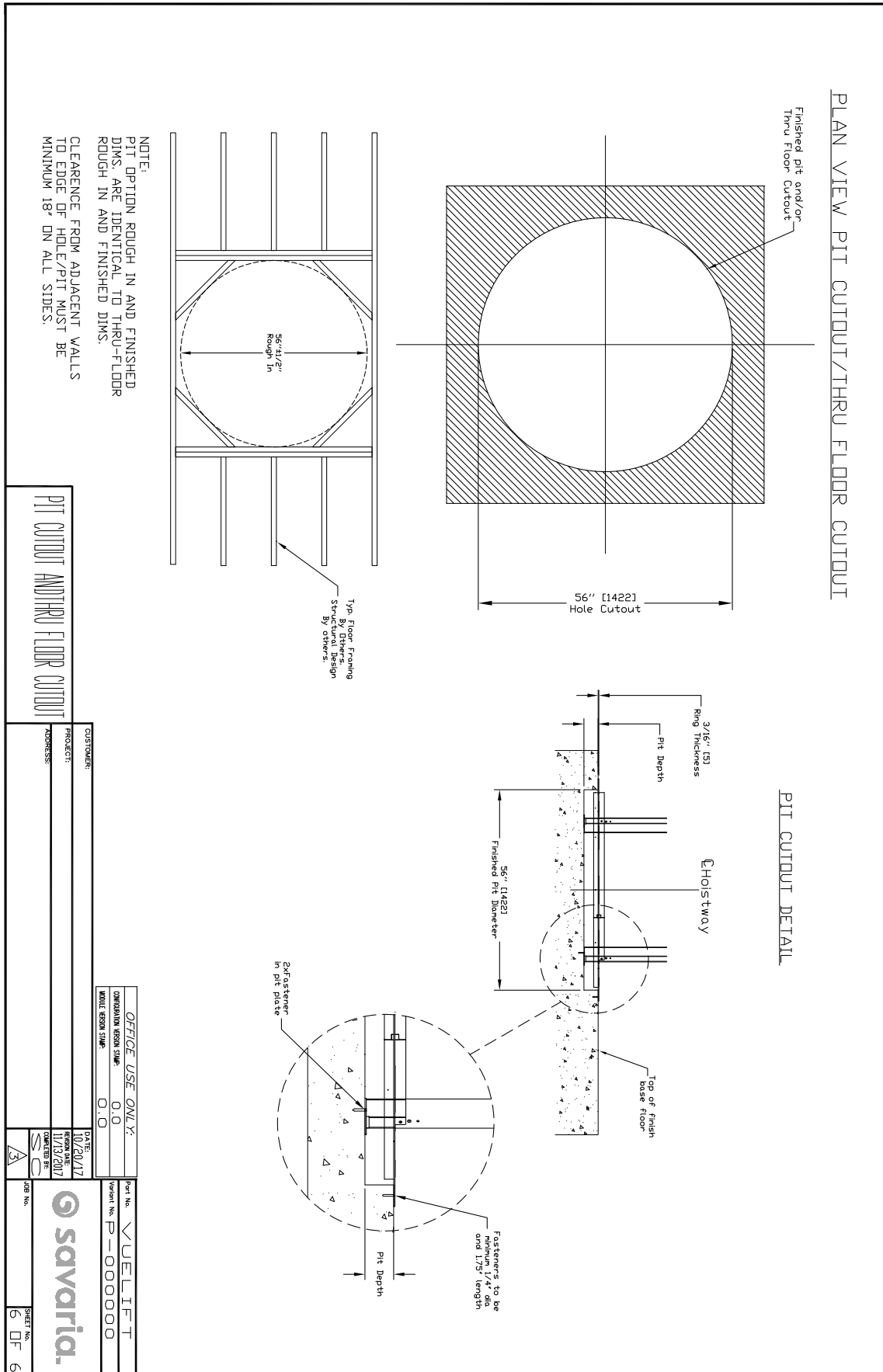
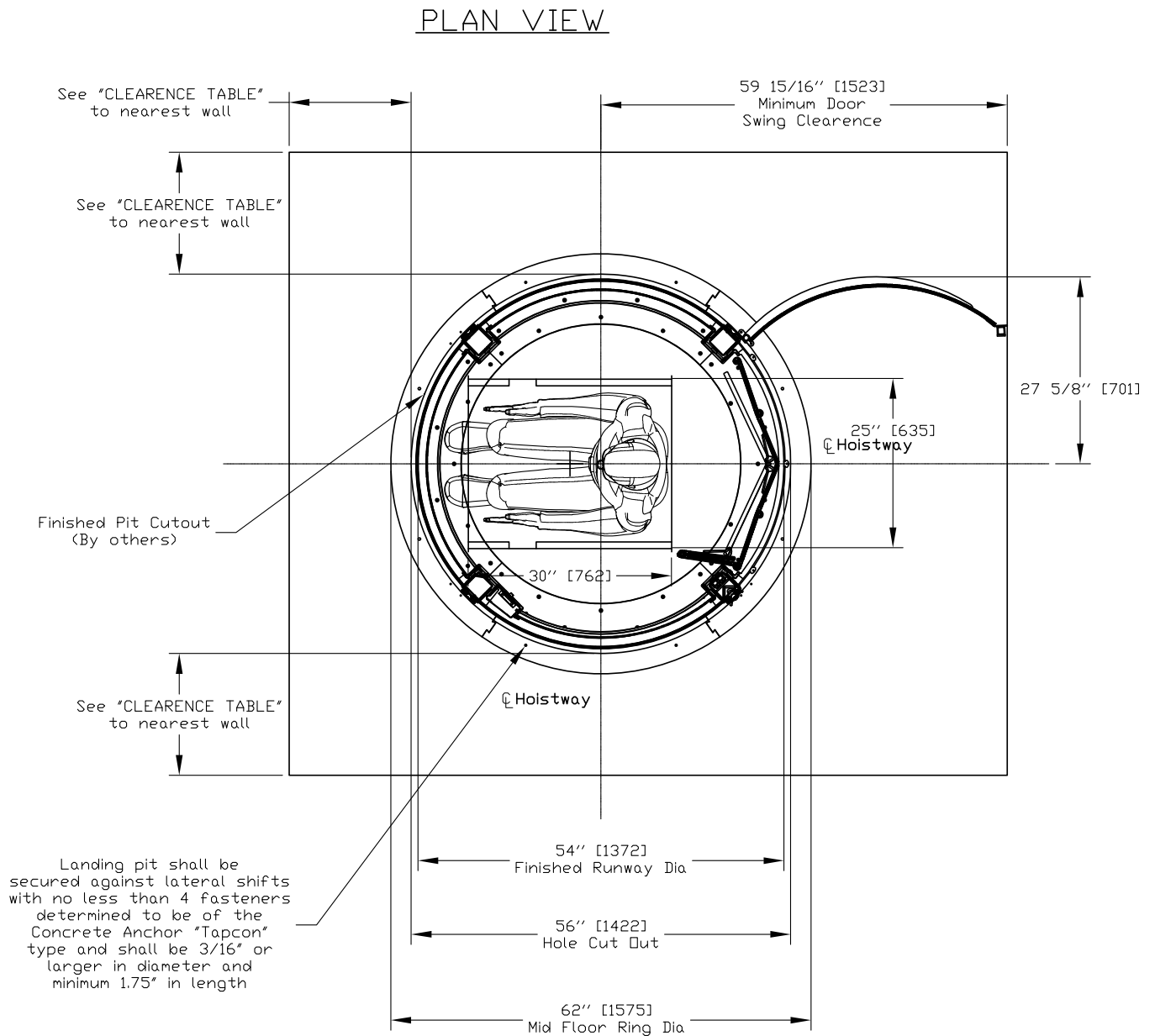

Figure 8: Wheelchair plan view (round)



Notes: * No footrest used on wheelchair.

** Size may vary. Please review with your local dealer the availability of a true size template to review if chair will fit.

Figure 9: Controller box and UPS dimensions

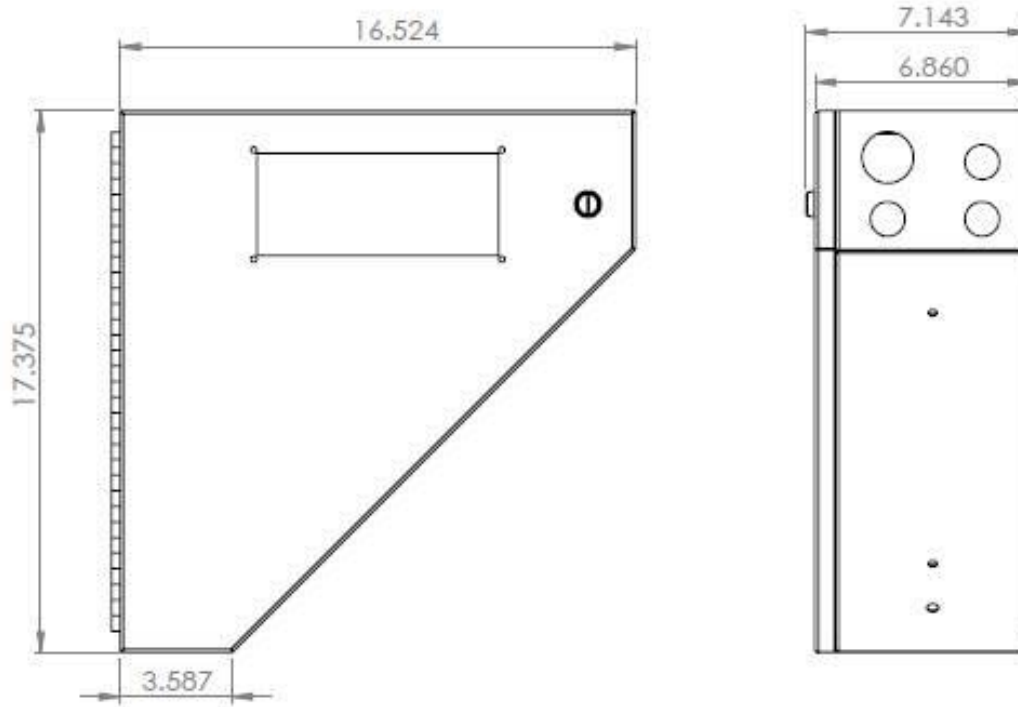

NOTE: A remote controller cannot be more than 50 feet (15.24 meters) away from the top of the unit in order for the cable to reach.

Chapter 2: Octagonal Elevator (Acrylic or Silica Glass)

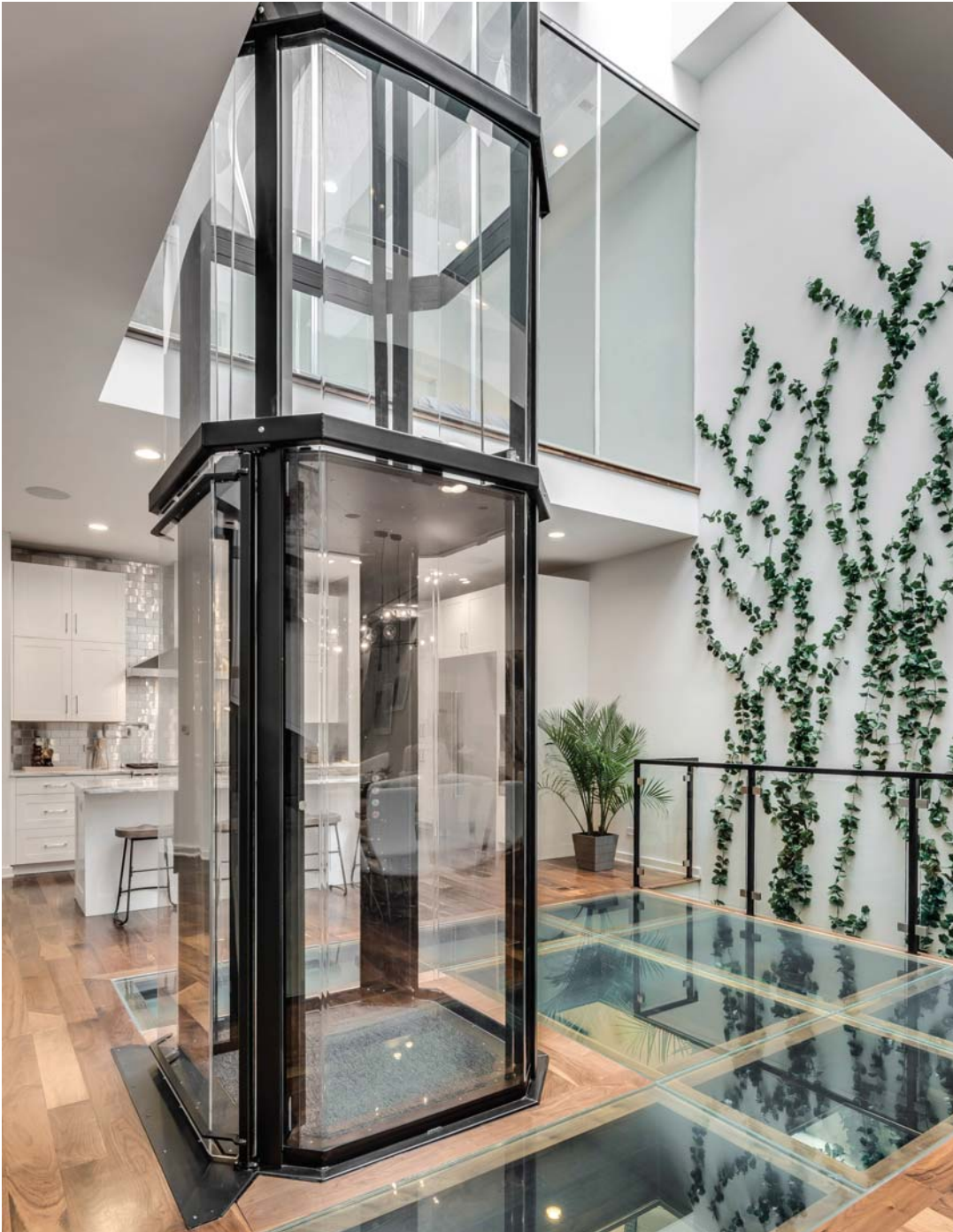

Specifications (Octagonal)

Specification	Specification Data
Load capacity	Acrylic model: 840 lb (381 kg) Silica glass model: 950lb (432 kg)
Maximum travel	42.5 ft (12.95 m)
Travel speed	Acrylic model: 32 ft/min (0.16 m/s) Silica glass model: 40 ft/min (0.20 m/s)
Noise level (for typical installation)	65 dB
Daily cycle	Normal: 40 Heavy: 80 Excessive: 150 Maximum starts in 1 hour on standard installation: 20 NOTE: Please consult your Sales Representative if there a chance you may exceed these amounts.
Maximum levels serviced	6
Minimum overhead	Acrylic model (standard cab): 106" (2692 mm) Acrylic model (optional short cab): 96" (2438 mm) Silica glass model: 108" (2743 mm)
Cab	Cab walls: Full clear acrylic or silica glass Cab interior height (standard): 84 in (2.13 m) Cab interior height (optional, acrylic only): 76.5 in (1.94 m) Cab weight (acrylic): 500 lb (250 kg) Cab weight (silica glass): 1000 lb (455 kg) Cab floor area: 12.83 sq ft (1.19 sq m)
Footprint	48" x 48" (1.2 m x 1.2 m)
Power supply	30A, 230-V, single-phase, 50/60 Hz
Cab lighting	15A, 115V, single-phase, 50/60 Hz
Suspension	Type: Galvanized aircraft cable (2 x 3/8" diameter) Construction: IWRC 7 x 19 RHRL Nominal strength: 14,400 lb (6,545 kg) Weight of ropes: 0.243 lb/ft (3.616 g/cm) Travel cable weight: 0.228 lb/ft (3.393 g/cm)
Drive train	Type: Winding drum Motor (acrylic model): 1.5 HP with integrated brake Motor (silica glass model): 3.0 HP with integrated brake Transmission: Ultra-low vibration, 3-stage, right-angle, helical-bevel drive Motor control: Preprogrammed variable frequency drive Door interlocks: Honeywell RDI-G-L5B certified (compliant with ASME A17.1 Section 2.12.4.3)
Pit/floor load	Refer to the section "Load Calculations"
Distance between 2 landings	93" (2362 mm) minimum
Pit depth	4" - 12" (102 mm - 305 mm) No pit with optional short ramp
Temperature	-10 °C to +40 °C (14 °F to 104 °F)

Specification	Specification Data
Safety features	Pit run/stop switch and car top run/stop switch Emergency stop switch Safety brakes Overspeed governor Manual lowering Emergency battery back-up for cab lighting and lowering
Options	Optional configurations: Type 1, 2, 3 Optional cab wall and hoistway: Acrylic or low-iron silica glass Optional colors: <ul style="list-style-type: none"> • White (Texture White PX521W859) • Silver (Texture Silver PX521S343) • Custom powder-coat frame Note that Black is the standard color (Texture Black PX622N365) Other options: Up to 6 stops, panoramic car ceiling, balcony attachment

Safety First (Octagonal)

3 & 5 rule (code prior to 2016)

The ASME A17.1/CSA-B44–Safety Code for Elevators and Escalators (**PRIOR TO 2016**) mandates the following maximum hoistway door clearances (see drawing on next page).

- Clearance between the hoistway door and the hoistway edge of the landing sill shall not exceed 3" (76 mm).
- Distance between the hoistway face of the landing door and the car door shall not exceed 5" (127 mm).
- Vuelift Residential Elevator design is with a maximum 1.25" (32 mm) running clearance.

3/4 & 4 rule (code 2016 and after)

The ASME A17.1-2016/CSA B44-16 Safety Code for Elevators and Escalators (**2016 AND AFTER**) mandates the following maximum hoistway door clearances (see drawing on next page):

- Clearance between the hoistway door and the hoistway edge of the landing sill shall not exceed 0.75" (19 mm).
- Distance between the hoistway face of the landing door and the car door shall not exceed 4" (102 mm).
- Vuelift Residential Elevator design is with a maximum 1.25" (32 mm) running clearance.

Electrical Requirements (Octagonal)

Your electrician and phone installer must supply the following connections:

- Main Disconnect - One 230V single-phase, 30 Amp fused disconnect box with 20 Amp fuse/breaker. If voltage is not 230V minimum, a buck-boost transformer is required.
- Lighting Disconnect - One 120V, 15 Amp fused disconnect or circuit breaker for cab lighting.
- Telephone Line - One telephone line jack is closes proximity to the controller.

NOTE: Savaria does not provide power cable to main disconnect.

Recommended manufacturers for fused disconnect

Square D

- Main disconnect: 230V single-phase disconnect model # H221N.
240V, 30 Amp with Interlock Kit - ELK031 Aux Contacts (normally opened/normally closed).
In addition, two each - 250V, 20 Amp, RK5 fuses.
- Lighting disconnect: 120V, 15 Amp fused disconnect or circuit breaker.

Siemens

- Main disconnect: 230V single-phase disconnect model #HF221N.
240V, 30 Amp with Interlock Kit-HA 161234 Aux Contacts (normally opened/normally closed).
In addition, two each - 250V, 20 Amp, RK5 fuses.
- Lighting disconnect: 120V, 15 Amp fused disconnect or circuit breaker.

G.E.

- Main disconnect: 230V single-phase disconnect model # TH3221.
240V, 30 Amp with Interlock Kit - THAUX21D Aux Contacts (normally opened/normally closed).
In addition, two each - 250V, 20 Amp, RK5 fuses.
- Lighting disconnect - 120V, 15 Amp fused disconnect or circuit breaker.

Cutler Hammer

- Main disconnect: 230V single-phase disconnect model # DH221NGK.
240V, 30 Amp with Interlock Kit - THAUX21D Aux Contacts (normally opened/normally closed).
In addition, two each - 250V, 20 Amp, RK5 fuses.
- Lighting disconnect: 120V, 15 Amp fused disconnect or circuit breaker.

Recommended manufacturers for circuit breakers at the distribution panel (and the distribution panel itself): Square D or Siemens only.

Provisions By Others (Octagonal)

General

Construction Site

The owner/agent is required to provide all masonry, carpentry, and drywall work as required. Floors shall be in a finished state prior to installation of the unit. Refer to the section, Site Preparation on the next page.

Dimensions

The contractor/customer must verify all clearance dimensions prior to delivery of the unit.

Structural Floor Loads

A structural engineer is required to ensure that the building will safely support all loads imposed by the lift equipment. Refer to the tables on the installation drawings (shop drawings) for pit/floor loads imposed by the equipment. Refer to the section, Load Calculations.

Electrical Power Supply

See the following table. Lockable fused disconnects must be installed in compliance with electrical code and are to be provided prior to installation of the unit. Roughed in power to the lift must be provided to the head assembly location prior to installation of the unit.

Power Supply Specifications	Disconnect Size	Time Delay Fuse Size	Volts	Phase
Motor and equipment	30 Amps	30 Amps	230 Volts	Single
Cab lights	15 Amps	15 Amps	115 Volts	Single

Telephone

If a telephone circuit is required, the jack is to be provided and installed by others. This circuit shall be brought to a location next to the controller and be available to connect and test upon elevator installation.

Permanent Power

Before installation can begin, permanent power must be supplied.

Entrances Handrails

All balcony levels require handrails to be installed per local codes after installation is completed. The handrail and installation is to be provided by the contractor/customer. Savaria Concord Lifts Inc. and/or local installer are not responsible for handrail installation or materials.

Site Preparation (Octagonal)

The following items **MUST** be completed prior to installation of the elevator.

Finished Floors

- Finished floors be installed at all landing levels.

230V Power (with Switched Disconnect)

- Permanent 230V, single-phase, 30-Ampere dedicated power to a lockable fused (cartridge type) disconnect switch.
- Disconnect switch must be mounted in a location within line of sight of the elevator or controller.
- 230V source must be run from the disconnect switch to a junction box in a discrete location at the top of the elevator hoistway location.
- Disconnect must be installed according to all applicable local codes.

110V Power (with Switched Disconnect)

- Permanent 110V, single-phase, 15-Ampere dedicated power to a lockable, fused (cartridge type) disconnect switch.
- Disconnect switch must be mounted near the 230V disconnect switch.

Telephone Works

- Telephone jack must be provided next to the electrical disconnects. This can be the common house line in most jurisdictions. Please check with your local installer or building contractor for code requirements.

Floor Built for Load

- Smooth level surface for installing the elevator, with floor load bearing capacity for the elevator plus rated load. An exact specification can be provided by contacting Savaria.

Floor and Pit Cutouts Complete

- If a pit is to be used, a smooth, level surface of at least 4" must be provided. For pit depths greater than 12", contact Savaria to ensure proper equipment will be provided.
- It is recommended that any pit floor and walls be finished prior to installation. Pit floor and walls are visible after elevator installation is completed.
- Hole in floor, or modified balcony rail as directed by drawings.

Check Floor to Floor Maximum and Minimum Distances

- 106" (2692 mm) minimum overhead distance from upper floor level to the underside of the finished ceiling for standard cab configuration.
- 96" (2438 mm) minimum overhead distance from upper floor level to the underside of the finished ceiling for modified short cab configuration.
- 108" (2743 mm) minimum overhead distance from upper floor level to the underside of the finished ceiling for silica glass model.

Drywall and Painting

- All drywall and painting must be complete.

Load Calculations (Octagonal Acrylic)

- Primary loads are carried by the four support columns that run from top to bottom on the elevator.
- The load (represented below as Lower Floor Total Load) is supported on 4"x4" plates at the bottom of each of the four columns.
- Vuelift elevators are designed such that the dead load and impact load are transferred to the lowest level through the rail base plates and rings when installed properly in a building with structural integrity including consistent floor to floor heights.
 - Note: Vuelift elevators are designed for applications in buildings that maintain consistent floor to floor height as the building ages.
 - If floor to floor height changes after installation, the elevator **MUST** be taken out of service pending inspection and correction by a trained installation technician.
- All mid floors including the bottom floor may be subjected to a maximum lateral load of 200 lb.
- Walls of bricks, terra-cotta, hollow blocks, and similar materials shall not be used for attachment of column (guide rail) brackets unless adequately reinforced.
- Where necessary, the building construction shall be reinforced to provide adequate support for the columns (guide rails).
- Shipping weight is estimated actual including crating materials, etc.
- Floor load figures include elevator structure weight when loaded with full test capacity.
- Floor load figures shown here are actual loads; your building engineer must add a proper factor of safety to the floor design.
- Many jurisdictions require floor designs to include at least a safety factor of 2.0, doubling the loads shown here.
- **To reiterate, these figures DO NOT include your factor of safety for floor loads.** Engineer your floor to include (add) an appropriate safety factor and comply with local building codes.

Lower Floor Dead Load (lbf) = (38 x feet of hoistway) + (60 x number of floors) + 2193

Lower Floor Impact Load (lbf) = 3703

Lower Floor Total Load (lbf) = Dead Load + Impact Load

Mid Floor Load (lbf) = 182

Shipping Weight (lb) = (694 x number of floors) + 1720

Note: Shipping weight includes the actual component weights for all parts, plus shipping crate and packaging weight.

Examples

	<u>3 stop with 36' of hoistway</u>	<u>2 stop with 19' hoistway</u>
Lower Floor Dead Load	3,741	3,035
Lower Floor Impact Load	<u>3,703</u>	<u>3,703</u>
Lower Floor Total Load	7,444	6,738
Mid Floor Loads (on each mid floor)	182	182
Shipping Weight	3,802	3,108

Load Calculations (Octagonal Silica Glass)

- Primary loads are carried by the four support columns that run from top to bottom on the elevator.
- The load (represented below as Lower Floor Total Load) is supported on 4"x4" plates at the bottom of each of the four columns.
- Each middle floor carries a separate Mid Floor Load supporting only that floor's metal floor rings, while the main cab/hoistway load (Lower Floor Total Load) is transferred fully to the bottom floor.
- Walls of bricks, terra-cotta, hollow blocks, and similar materials shall not be used for attachment of column (guide rail) brackets unless adequately reinforced.
- Where necessary, the building construction shall be reinforced to provide adequate support for the columns (guide rails).
- Shipping weight is estimated actual including crating materials, etc.
- Floor load figures include elevator structure weight when loaded with full test capacity.
- Floor load figures shown here are actual loads; your building engineer must add a proper factor of safety to the floor design.
- Many jurisdictions require floor designs to include at least a safety factor of 2.0, doubling the loads shown here
- **To reiterate, these figures DO NOT include your factor of safety for floor loads.** Engineer your floor to include (add) an appropriate safety factor and comply with local building codes.

$$\text{Lower Floor Dead Load (lbf)} = (143.0 \times \text{feet of hoistway}) + (340 \times \text{number of floors}) + 3100$$

$$\text{Lower Floor Impact Load (lbf)} = 7491$$

$$\text{Lower Floor Total Load (lbf)} = \text{Dead Load} + \text{Impact Load}$$

$$\text{Mid Floor Load (lbf)} = 200$$

$$\text{Shipping Weight (lb)} = (1967 \times \text{number of floors}) + 2562$$

Note: Shipping weight includes the actual component weights for all parts, plus shipping crate and packaging weight.

Examples

3 stop with 32.2' of hoistway

Lower Floor Dead Load	8,725
Lower Floor Impact Load	<u>7,491</u>
Lower Floor Total Load	16,759

Total Load is distributed as follows:

- At any point in time, two opposing columns may have up to 12,000 lbf (6000 lbf/column)
- However, the max load carried by all four column combined will not exceed 16,759 lbf before addition of factor of safety required by local building code.

Mid Floor Loads (on each mid floor)	200
-------------------------------------	-----

Shipping Weight	8,463
-----------------	-------

Drawings (Octagonal)

TYPE 1

- Plan view
- Pit/bottom floor/thru-floor view
- Balcony details
- Thru-floor details
- Elevation view
- Provisions by others (acrylic models)
- Pit cutout/thru-floor cutout

TYPE 2 (Octagonal Glass)

- Plan view
- Pit/bottom floor/thru-floor view
- Balcony details
- Elevation view
- Provisions by others (glass models)
- Pit cutout/thru-floor cutout

Wheelchair plan view (octagonal)

Controller box and UPS

Figure 11: Pit/bottom floor/thru-floor view (octagonal, type 1)

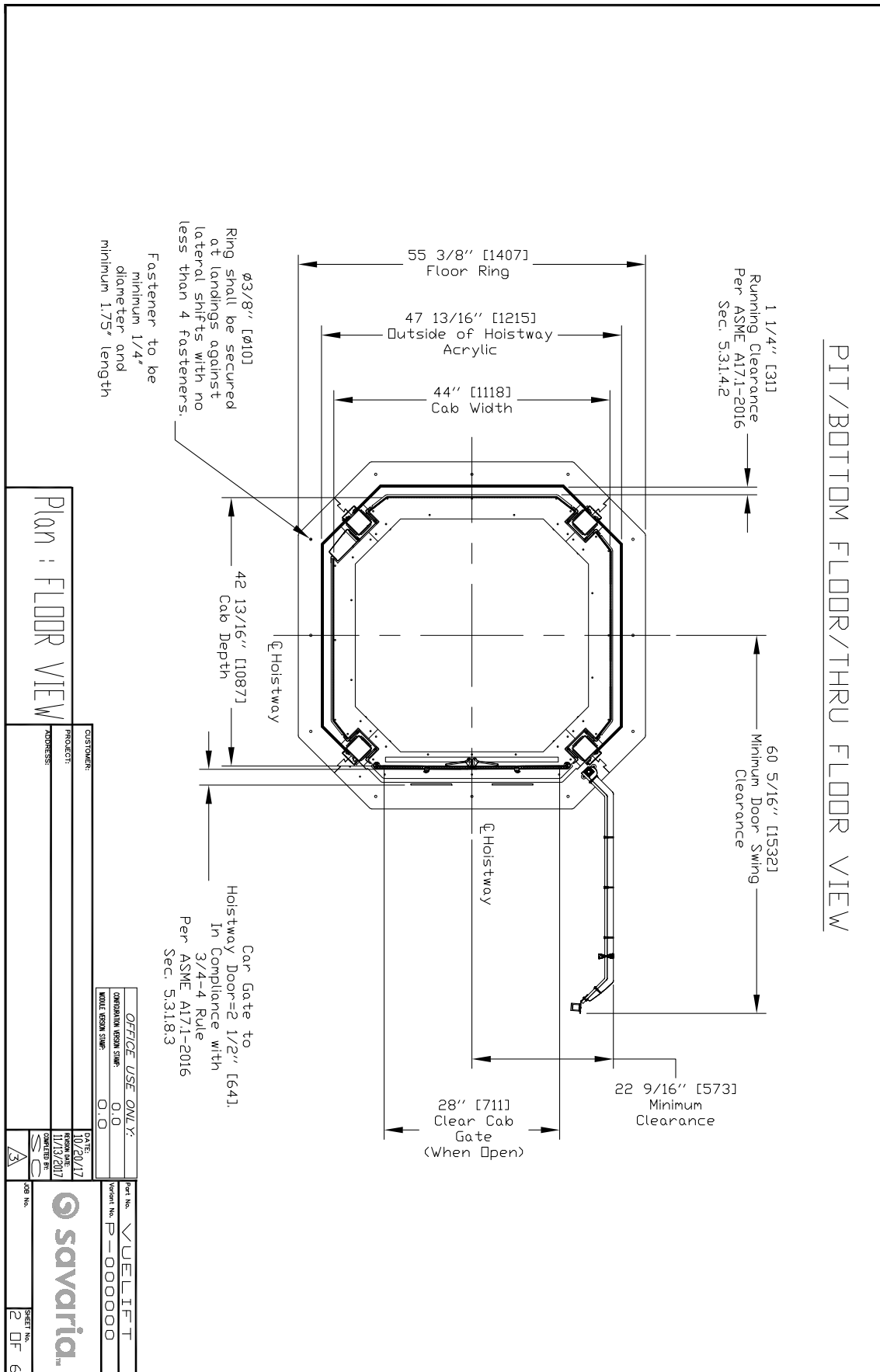

Figure 14: Elevation view (octagonal, type 1)

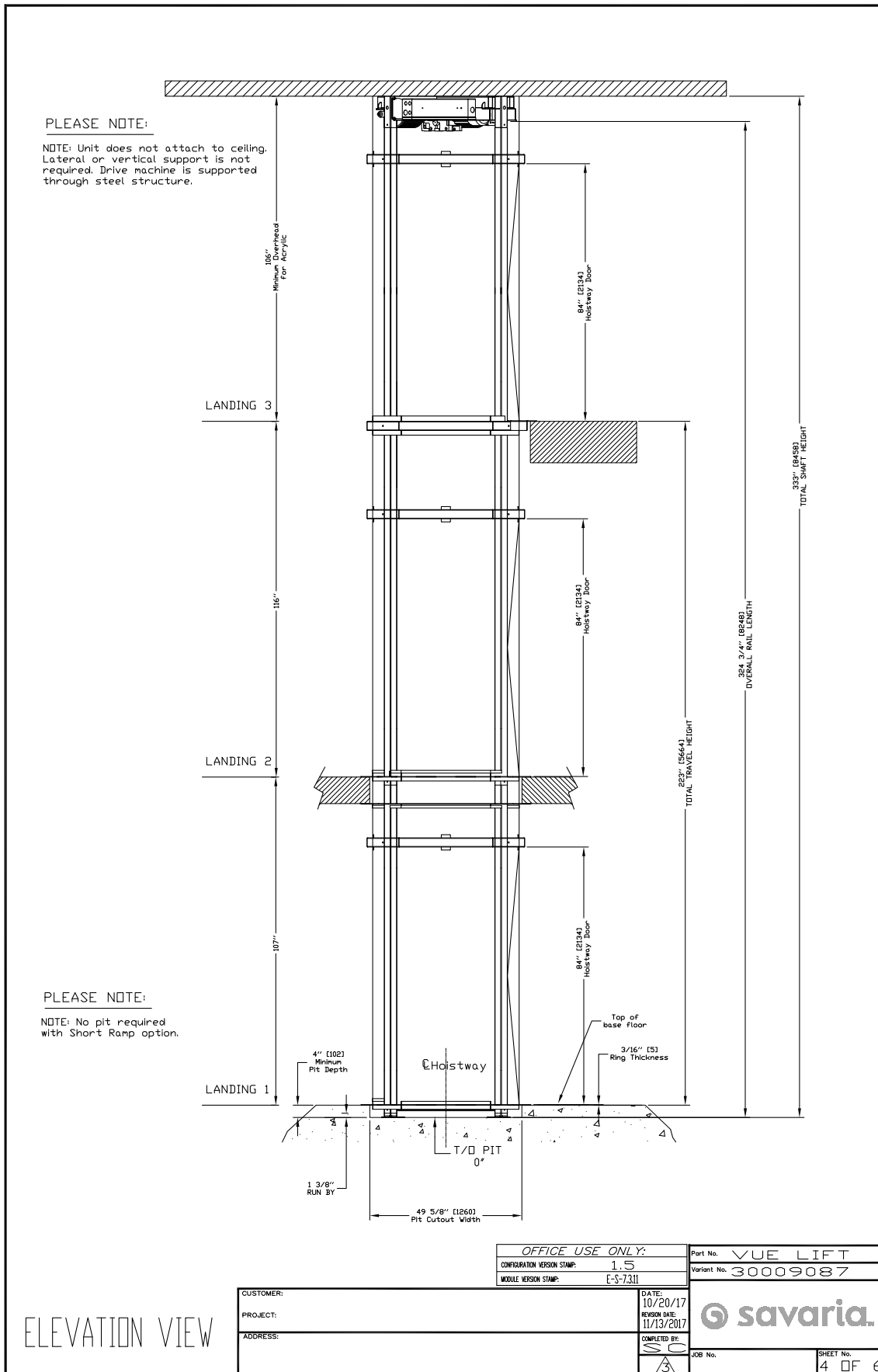

Figure 15: Provisions by others (octagonal, acrylic models, type 1)

PROVISIONS BY OTHERS

GENERAL

CLASSIFICATION: Residential Building
 APPLIED CODE: ASME 171-2016 SEC. 5.3
 NCC 2008
 Full Clear Acrylic-Complies with ANSI 297.1

VALTS: _____
 NUMBER OF FLOORS: 3
 MODEL: Octagonal Acrylic
 CAPACITY: 840 lbs. (381) kg)
 NOMINAL SPEED: 32 Fpm. (10.1666 m/s)
 CAB FLOOR AREA: 11.91 Square Feet (1.11 square meters)
 CAB INT HEIGHT: 84 Inches (2133 mm)
 CAB WEIGHT: 700 lbs. (318kg)
 TOTAL TRAVEL: 339 Inches
 PIT DEPTH (OPTIM): 4 Inches (102-305mm)
 POWER SUPPLY: 50/60Hz Single Phase 230V
 SAFETIES: 2 Type A Instantaneous Safeties in compliance with ASME A17.1 Sections 217.81 & 117.51
 Hfg Savaria P/N VL581001-01

SUSPENSION:

TYPE: Galvanized Aircraft Cable 2x3/8" dia
 CONSTRUCTION: 1xRC 7 x 19 RHRL
 NOMINAL STRENGTH: 14,400 lbs. (6531 kg)
 WT. OF ROPES: 0.243 lbs/ft (3.616 g/cm)
 TRAVEL CABLE WT: 0.228 lbs/ft (3.393 g/cm)

DRIVE/TRAIN:

TYPE: Winding Drum
 MOTOR: 1/2 HP with Integrated Brake
 TRANSMISSION: Ultra-Low Vibration 5-Stage Right Angle Helical-Bevel Drive
 MOTOR CONTROL: Pre-Programmed Variable Freq. Drive
 DOOR INTRLOCKS: Honeywell RII-0-12B certified in compliance with ASME A17.1 Sections 212.4.3
 PIT/FLOOR LOAD: _____ (ft of Hoistway*38) + (ft of Floor*60) + 2193 Dead Load (lbs) 3703 lbs Impact Load (in of Hoistway*56) + (ft of Floor*27/22) + 995 Dead Load (lbs) 1680 kg Impact Load

GENERAL

CONTRACTOR/CUSTOMER TO PROVIDE ALL NECESSARY CONCRETE AND REINFORCEMENT FOR ALL DIMENSIONS AND TO VERIFY ALL DIMENSIONS PRIOR TO UNIT BELIEVER.
 CONTRACTOR/CUSTOMER TO VERIFY ALL DIMENSIONS PRIOR TO UNIT BELIEVER.

STRUCTURAL

FLOOR LOADS: STRUCTURAL ENGINEER TO ASSURE THAT BUILDING VALL, SLAB, BEAMS, AND BRACINGS ARE CAPABLE OF SUPPORTING THE WEIGHT OF THIS DRIVING FOR PIT/FLOOR LOADS IMPOSED BY THE EQUIPMENT.
 NOTE: PER ASME A17-2016 THE CLEARANCE BETWEEN THE HOISTWAY DOORS OR GATES AND THE HOISTWAY BEAMS OF THE LANDING BETWEEN THE HOISTWAY DOORS OR GATES AND THE HOISTWAY BEAMS OF THE LANDING DOOR OR GATE AND THE CAR DOOR OR GATE SHALL NOT EXCEED 3/8 IN.
 ELECTRICAL: PROVIDE SPACELY SET SPECIFICATIONS BEHIND LOCKABLE FUSED DISCONNECTS. INSTALLATION EQUIPPED IN POWER TO LIFT UNIT MUST BE PROVIDED PRIOR TO PERMANENT INSTALLATION PRIOR TO INSTALLATION.
 PERMANENT POWER BEFORE INSTALLATION CAN BEGUN. PERMANENT POWER MUST BE PROVIDED PRIOR TO INSTALLATION.

INSTALLANCES

CONTRACTOR/CUSTOMER TO PROVIDE ALL NECESSARY CONCRETE AND REINFORCEMENT FOR ALL DIMENSIONS AND TO VERIFY ALL DIMENSIONS PRIOR TO UNIT BELIEVER.
 CONTRACTOR/CUSTOMER TO VERIFY ALL DIMENSIONS PRIOR TO UNIT BELIEVER.

MECHANICAL

CONTRACTOR/CUSTOMER TO PROVIDE ALL NECESSARY CONCRETE AND REINFORCEMENT FOR ALL DIMENSIONS AND TO VERIFY ALL DIMENSIONS PRIOR TO UNIT BELIEVER.
 CONTRACTOR/CUSTOMER TO VERIFY ALL DIMENSIONS PRIOR TO UNIT BELIEVER.

WATER

CONTRACTOR/CUSTOMER TO PROVIDE ALL NECESSARY CONCRETE AND REINFORCEMENT FOR ALL DIMENSIONS AND TO VERIFY ALL DIMENSIONS PRIOR TO UNIT BELIEVER.
 CONTRACTOR/CUSTOMER TO VERIFY ALL DIMENSIONS PRIOR TO UNIT BELIEVER.

TELEPHONE

CONTRACTOR/CUSTOMER TO PROVIDE ALL NECESSARY CONCRETE AND REINFORCEMENT FOR ALL DIMENSIONS AND TO VERIFY ALL DIMENSIONS PRIOR TO UNIT BELIEVER.
 CONTRACTOR/CUSTOMER TO VERIFY ALL DIMENSIONS PRIOR TO UNIT BELIEVER.

TELEVISION

CONTRACTOR/CUSTOMER TO PROVIDE ALL NECESSARY CONCRETE AND REINFORCEMENT FOR ALL DIMENSIONS AND TO VERIFY ALL DIMENSIONS PRIOR TO UNIT BELIEVER.
 CONTRACTOR/CUSTOMER TO VERIFY ALL DIMENSIONS PRIOR TO UNIT BELIEVER.

TELEPHONE

CONTRACTOR/CUSTOMER TO PROVIDE ALL NECESSARY CONCRETE AND REINFORCEMENT FOR ALL DIMENSIONS AND TO VERIFY ALL DIMENSIONS PRIOR TO UNIT BELIEVER.
 CONTRACTOR/CUSTOMER TO VERIFY ALL DIMENSIONS PRIOR TO UNIT BELIEVER.

TELEVISION

CONTRACTOR/CUSTOMER TO PROVIDE ALL NECESSARY CONCRETE AND REINFORCEMENT FOR ALL DIMENSIONS AND TO VERIFY ALL DIMENSIONS PRIOR TO UNIT BELIEVER.
 CONTRACTOR/CUSTOMER TO VERIFY ALL DIMENSIONS PRIOR TO UNIT BELIEVER.

TELEPHONE

CONTRACTOR/CUSTOMER TO PROVIDE ALL NECESSARY CONCRETE AND REINFORCEMENT FOR ALL DIMENSIONS AND TO VERIFY ALL DIMENSIONS PRIOR TO UNIT BELIEVER.
 CONTRACTOR/CUSTOMER TO VERIFY ALL DIMENSIONS PRIOR TO UNIT BELIEVER.

TELEVISION

CONTRACTOR/CUSTOMER TO PROVIDE ALL NECESSARY CONCRETE AND REINFORCEMENT FOR ALL DIMENSIONS AND TO VERIFY ALL DIMENSIONS PRIOR TO UNIT BELIEVER.
 CONTRACTOR/CUSTOMER TO VERIFY ALL DIMENSIONS PRIOR TO UNIT BELIEVER.

GENERAL

CLASSIFICATION: Residential Building
 APPLIED CODE: ASME 171-2016 SEC. 5.3
 NCC 2008
 Full Clear Acrylic-Complies with ANSI 297.1

VALTS: _____
 NUMBER OF FLOORS: 3
 MODEL: Octagonal Acrylic
 CAPACITY: 840 lbs. (381) kg)
 NOMINAL SPEED: 32 Fpm. (10.1666 m/s)
 CAB FLOOR AREA: 11.91 Square Feet (1.11 square meters)
 CAB INT HEIGHT: 84 Inches (2133 mm)
 CAB WEIGHT: 700 lbs. (318kg)
 TOTAL TRAVEL: 339 Inches
 PIT DEPTH (OPTIM): 4 Inches (102-305mm)
 POWER SUPPLY: 50/60Hz Single Phase 230V
 SAFETIES: 2 Type A Instantaneous Safeties in compliance with ASME A17.1 Sections 217.81 & 117.51
 Hfg Savaria P/N VL581001-01

SUSPENSION:

TYPE: Galvanized Aircraft Cable 2x3/8" dia
 CONSTRUCTION: 1xRC 7 x 19 RHRL
 NOMINAL STRENGTH: 14,400 lbs. (6531 kg)
 WT. OF ROPES: 0.243 lbs/ft (3.616 g/cm)
 TRAVEL CABLE WT: 0.228 lbs/ft (3.393 g/cm)

DRIVE/TRAIN:

TYPE: Winding Drum
 MOTOR: 1/2 HP with Integrated Brake
 TRANSMISSION: Ultra-Low Vibration 5-Stage Right Angle Helical-Bevel Drive
 MOTOR CONTROL: Pre-Programmed Variable Freq. Drive
 DOOR INTRLOCKS: Honeywell RII-0-12B certified in compliance with ASME A17.1 Sections 212.4.3
 PIT/FLOOR LOAD: _____ (ft of Hoistway*38) + (ft of Floor*60) + 2193 Dead Load (lbs) 3703 lbs Impact Load (in of Hoistway*56) + (ft of Floor*27/22) + 995 Dead Load (lbs) 1680 kg Impact Load

GENERAL

CONTRACTOR/CUSTOMER TO PROVIDE ALL NECESSARY CONCRETE AND REINFORCEMENT FOR ALL DIMENSIONS AND TO VERIFY ALL DIMENSIONS PRIOR TO UNIT BELIEVER.
 CONTRACTOR/CUSTOMER TO VERIFY ALL DIMENSIONS PRIOR TO UNIT BELIEVER.

STRUCTURAL

FLOOR LOADS: STRUCTURAL ENGINEER TO ASSURE THAT BUILDING VALL, SLAB, BEAMS, AND BRACINGS ARE CAPABLE OF SUPPORTING THE WEIGHT OF THIS DRIVING FOR PIT/FLOOR LOADS IMPOSED BY THE EQUIPMENT.
 NOTE: PER ASME A17-2016 THE CLEARANCE BETWEEN THE HOISTWAY DOORS OR GATES AND THE HOISTWAY BEAMS OF THE LANDING BETWEEN THE HOISTWAY DOORS OR GATES AND THE HOISTWAY BEAMS OF THE LANDING DOOR OR GATE AND THE CAR DOOR OR GATE SHALL NOT EXCEED 3/8 IN.
 ELECTRICAL: PROVIDE SPACELY SET SPECIFICATIONS BEHIND LOCKABLE FUSED DISCONNECTS. INSTALLATION EQUIPPED IN POWER TO LIFT UNIT MUST BE PROVIDED PRIOR TO PERMANENT INSTALLATION PRIOR TO INSTALLATION.
 PERMANENT POWER BEFORE INSTALLATION CAN BEGUN. PERMANENT POWER MUST BE PROVIDED PRIOR TO INSTALLATION.

INSTALLANCES

CONTRACTOR/CUSTOMER TO PROVIDE ALL NECESSARY CONCRETE AND REINFORCEMENT FOR ALL DIMENSIONS AND TO VERIFY ALL DIMENSIONS PRIOR TO UNIT BELIEVER.
 CONTRACTOR/CUSTOMER TO VERIFY ALL DIMENSIONS PRIOR TO UNIT BELIEVER.

MECHANICAL

CONTRACTOR/CUSTOMER TO PROVIDE ALL NECESSARY CONCRETE AND REINFORCEMENT FOR ALL DIMENSIONS AND TO VERIFY ALL DIMENSIONS PRIOR TO UNIT BELIEVER.
 CONTRACTOR/CUSTOMER TO VERIFY ALL DIMENSIONS PRIOR TO UNIT BELIEVER.

WATER

CONTRACTOR/CUSTOMER TO PROVIDE ALL NECESSARY CONCRETE AND REINFORCEMENT FOR ALL DIMENSIONS AND TO VERIFY ALL DIMENSIONS PRIOR TO UNIT BELIEVER.
 CONTRACTOR/CUSTOMER TO VERIFY ALL DIMENSIONS PRIOR TO UNIT BELIEVER.

TELEPHONE

CONTRACTOR/CUSTOMER TO PROVIDE ALL NECESSARY CONCRETE AND REINFORCEMENT FOR ALL DIMENSIONS AND TO VERIFY ALL DIMENSIONS PRIOR TO UNIT BELIEVER.
 CONTRACTOR/CUSTOMER TO VERIFY ALL DIMENSIONS PRIOR TO UNIT BELIEVER.

TELEVISION

CONTRACTOR/CUSTOMER TO PROVIDE ALL NECESSARY CONCRETE AND REINFORCEMENT FOR ALL DIMENSIONS AND TO VERIFY ALL DIMENSIONS PRIOR TO UNIT BELIEVER.
 CONTRACTOR/CUSTOMER TO VERIFY ALL DIMENSIONS PRIOR TO UNIT BELIEVER.

TELEPHONE

CONTRACTOR/CUSTOMER TO PROVIDE ALL NECESSARY CONCRETE AND REINFORCEMENT FOR ALL DIMENSIONS AND TO VERIFY ALL DIMENSIONS PRIOR TO UNIT BELIEVER.
 CONTRACTOR/CUSTOMER TO VERIFY ALL DIMENSIONS PRIOR TO UNIT BELIEVER.

TELEVISION

CONTRACTOR/CUSTOMER TO PROVIDE ALL NECESSARY CONCRETE AND REINFORCEMENT FOR ALL DIMENSIONS AND TO VERIFY ALL DIMENSIONS PRIOR TO UNIT BELIEVER.
 CONTRACTOR/CUSTOMER TO VERIFY ALL DIMENSIONS PRIOR TO UNIT BELIEVER.

TELEPHONE

CONTRACTOR/CUSTOMER TO PROVIDE ALL NECESSARY CONCRETE AND REINFORCEMENT FOR ALL DIMENSIONS AND TO VERIFY ALL DIMENSIONS PRIOR TO UNIT BELIEVER.
 CONTRACTOR/CUSTOMER TO VERIFY ALL DIMENSIONS PRIOR TO UNIT BELIEVER.

TELEVISION

CONTRACTOR/CUSTOMER TO PROVIDE ALL NECESSARY CONCRETE AND REINFORCEMENT FOR ALL DIMENSIONS AND TO VERIFY ALL DIMENSIONS PRIOR TO UNIT BELIEVER.
 CONTRACTOR/CUSTOMER TO VERIFY ALL DIMENSIONS PRIOR TO UNIT BELIEVER.

ENTRANCE SIDE LEGEND

LANDING CHART

DOOR TYPE	LANDING 1	LANDING 2	LANDING 3	LANDING 4	LANDING 5	LANDING 6
DOOR ENTRANCE SIDE	S.WING	DOORSWING	DOORSWING	DOOR	NA	NA
DOOR SWING	RH SWING	C	RH SWING	C	NA	NA
HALL CALL KEY SWITCH	HIDDEN	WELL	HIDDEN	WELL	NA	NA
FLOOR MARKING	PT1				NA	NA
LANDING CONFIGURATION		THIRDFLOOR		BALCONY		

DATA SHEET

CUSTOMER	PROJECT	COMPLETION DATE	OFFICE USE ONLY:
			OPERATION REGION SHIP: 1.5
			MODEL REGION SHIP: E5/7011
			DATE: 10/30/17
			ISSUE DATE: 11/13/2017
			COMPLETED BY: S.C.
			APP. NO.:
			REP. NO.:
			SAVARIA
			SHEET NO. 5 OF 6

Figure 17: Plan view (octagonal glass, type 2)

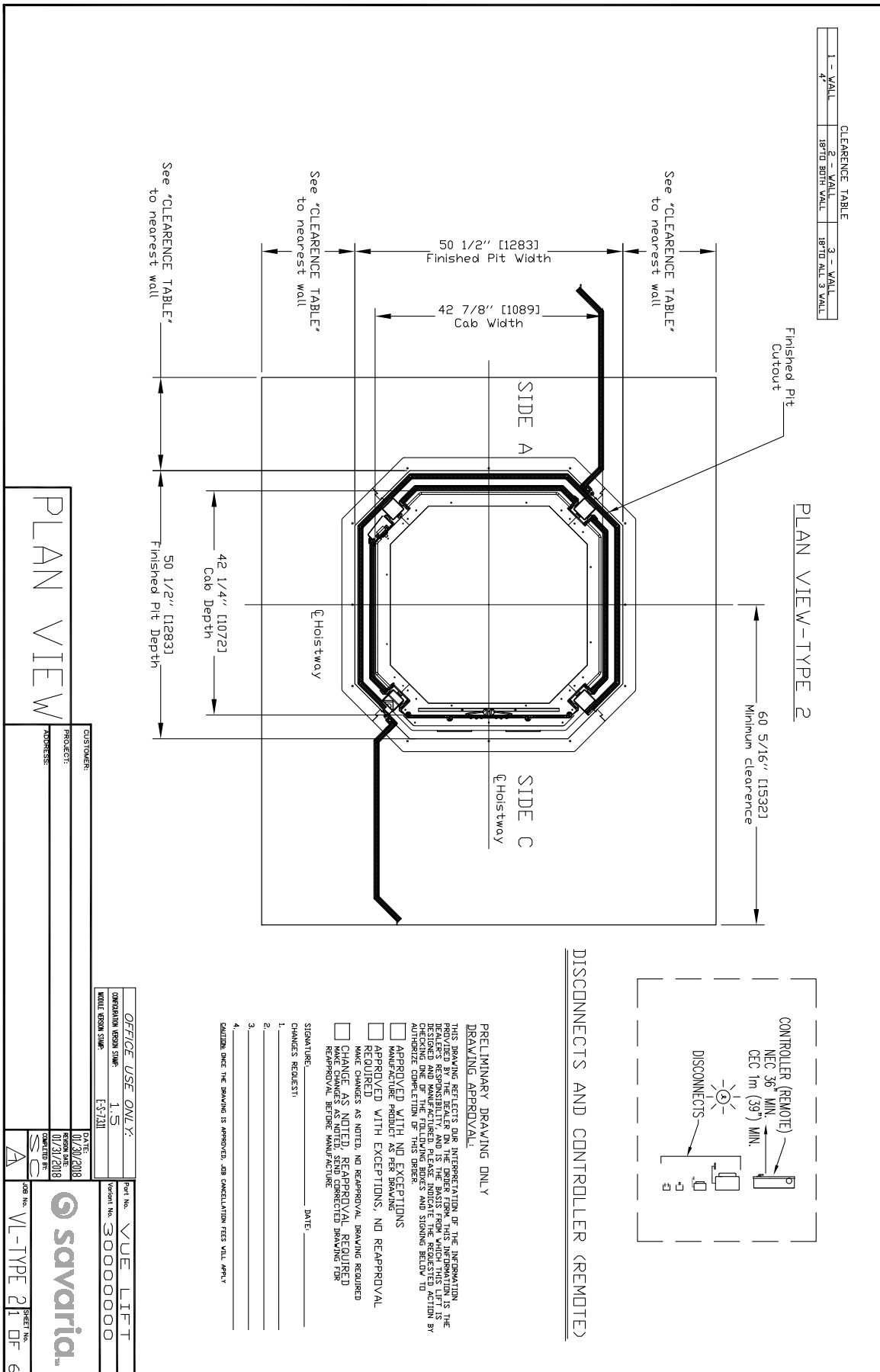

Figure 18: Pit/bottom floor/thru-floor view (octagonal glass, type 2)

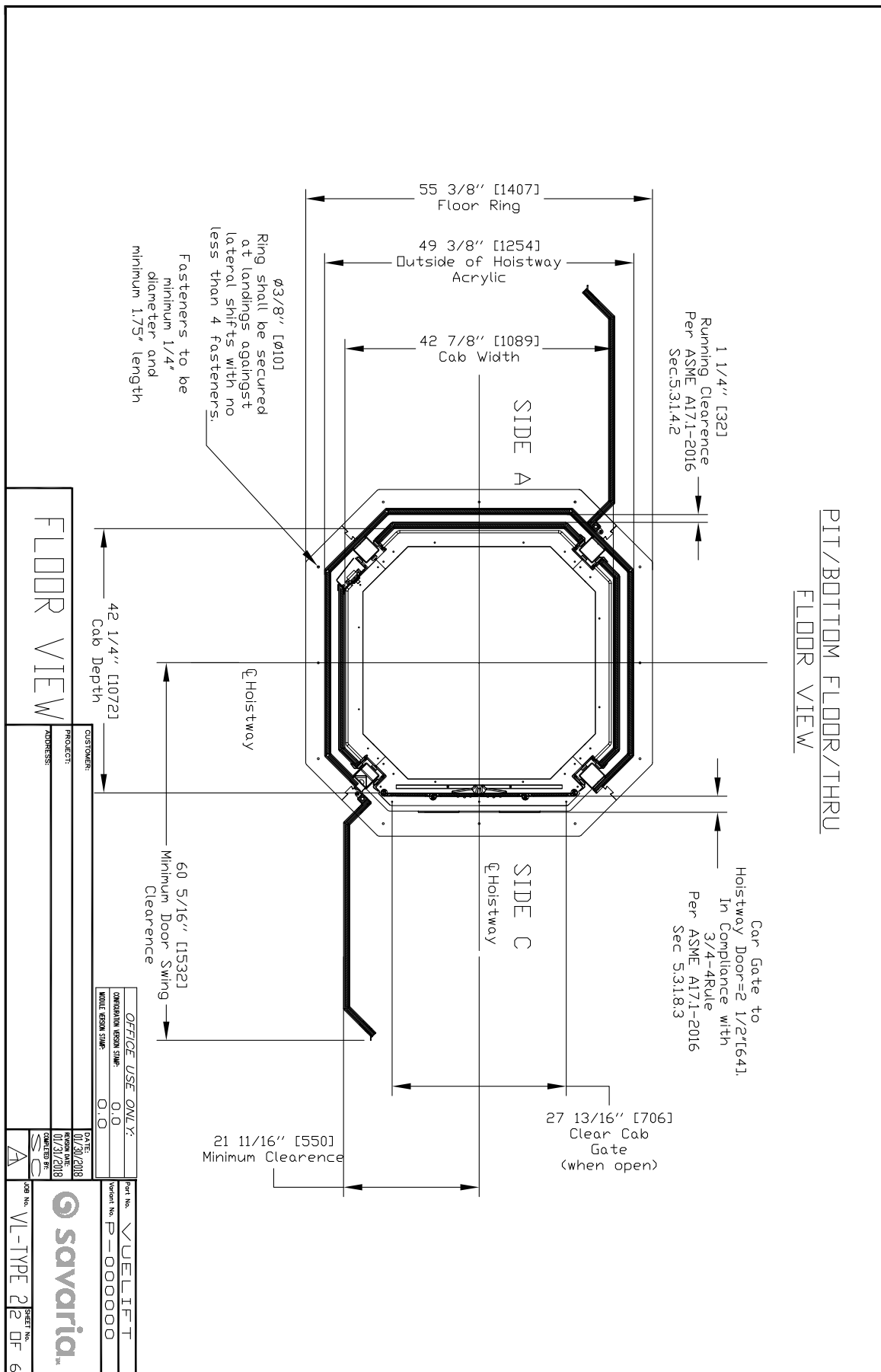

Figure 20: Elevation view (octagonal glass, type 2)

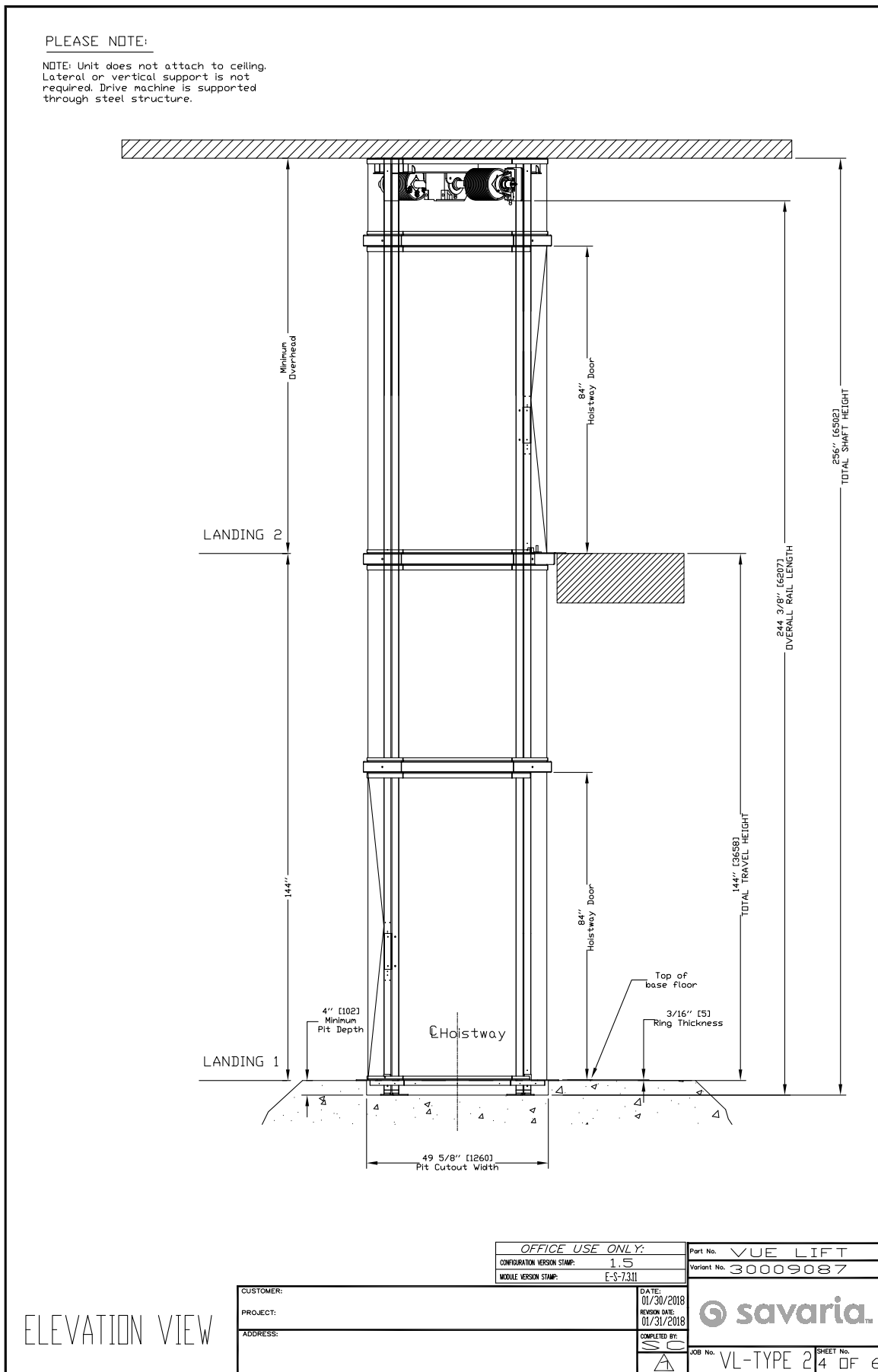

Figure 21: Provisions by others (octagonal glass, type 2)

PROVISIONS BY OTHERS

GENERAL
GENERAL SITE, OWNER/AGENT TO PROVIDE ALL MASONRY, CARPENTRY AND IRONWORK AS REQUIRED. FLOORS SHALL BE IN FINISHED STATE PRIOR TO INSTALLATION OF UNIT.
DISCUSSIONS, CONTRACTOR/CUSTOMER TO VERIFY ALL CLEARANCE DIMENSIONS PRIOR TO UNIT DELIVERY.

STRUCTURAL
FLOOR LOADS STRUCTURAL ENGINEER TO ASSURE THAT BUILDING WITH SAFETY SURROUNDING AREA IS PROPERLY DESIGNED TO SUPPORT THE WEIGHT OF THIS DRAWING FOR PIT/FLOOR LOADS IMPOSED BY THE EQUIPMENT.
NOTE: PER ASME A17.1-2016, THE HOISTWAY DOORS OR GATES AND THE HOISTWAY ROPE OF THE CARRIER BETWEEN THE HOISTWAY DOORS OR GATES AND THE HOISTWAY FACE OF THE LANDING DOOR OR GATE AND THE CAR DOOR OR GATE SHALL NOT EXCEED 500 LBS.
ELECTRICAL
ELECTRICAL SPECIFICATIONS RELY ON LOCKABLE FUSED DISCONNECTS INSTALLED IN COMPLIANCE WITH ELECTRICAL CODE TO BE PROVIDED PRIOR TO INSTALLATION. REQUIRED IN POWER TO LIFT UNIT MUST BE PROVIDED PRIOR TO ASSEMBLY LOCATION PRIOR TO INSTALLATION.
PERMANENT POWER MUST BE PROVIDED PRIOR TO INSTALLATION.
ENTRANCES
HANDRAILS ALL BALKONY LEVELS REQUIRE HANDRAILS TO BE INSTALLED PER LOCAL CODES AND REGULATIONS, AS APPLICABLE.
HANDRAILS SHALL BE PROVIDED BY CONTRACTOR/CUSTOMER. VISIBILITY AND/OR LOCAL INSTALLER ARE NOT RESPONSIBLE FOR HANDRAIL INSTALLATION OR MATERIALS.

POWER SUPPLY SPECIFICATIONS	DISCONNECT	TIME DELAY	VOLTS	PHASE	AMPLITUDE
MOTOR & EQUIP: 120 AMPS, 230	FUSE SIZE			SINGLE	20A AMPS
CAR LIGHTS: 15 AMPS, 115					

If a telephone circuit is required, getting for elevators, work is required and installed by others. THIS CIRCUIT SHALL BE BROUGHT TO A LOCATION NEXT TO THE CONTROLLER AND BE AVAILABLE TO CONNECT AND TEST UPON ELEVATOR INSTALLATION.

***SCOPE OF WORK**
INSTALLATION OF A VUELIFT ELEVATOR BY A JOURNEY LEVEL, LICENSED GOVERNANCE AGENCY AND IS THE RESPONSIBILITY OF THE CONTRACTOR. ALL GOVERNING LOCAL, STATE AND FEDERAL CODES AND REGULATIONS SHALL BE THE RESPONSIBILITY OF THE FOLLOWING CODES AND STANDARDS:
ASME A17.1 SECTION 5.3 - SAFETY CODE FOR ELEVATORS AND ESCALATORS
PRIVATE RESIDENCE ELEVATORS
NFPA 70-2008 THE NATIONAL ELECTRICAL CODE
CSA B44/ASME A17.5 ELEVATOR AND ESCALATOR ELECTRICAL EQUIPMENT.
LOCAL CODES AND REGULATIONS, AS APPLICABLE.
AFTER INSTALLATION THE UNIT WILL BE INSPECTED BY AN INSPECTOR AS REQUIRED BY LOCAL LAWS.

GENERAL
CLASSIFICATION: Residential Building
APPLIED CODE: ASME 17.1-2016 SEC. 5.3
NEC 2008
VALTS: Full Clear Glass-Complies with ANSI Z97.1
NUMBER OF FLOORS: 2
MODEL: Octagonal Acrylic
CAPACITY: 950 lbs. (432 kg)
NOMINAL SPEED: 40 FPM (101626 m/s)
CAR FLOOR AREA: 1191 Square Feet (111 sqmeters)
CAR INT HEIGHT: 84 Inches (2133 mm)
CAR WEIGHT: 1160 lbs (530kg)
TOTAL TRAVEL: 144 Inches
PIT DEPTH (OPTI-D): 4 Inches (102-305mm)
POWER SUPPLY: 50/60Hz Single Phase 230V
SAFETIES: 2 Type A Instantaneous Safeties in compliance with ASME A17.1 Sections 2.17.81 & 1.17.51
Mfg Savaria P/N VL48000-01

SUSPENSION:
TYPE: Galvanized Aircraft Cable 2x3/8" dia
CONSTRUCTION: 17RC 7 x 19 RHRL
NOMINAL STRENGTH: 14,400 lbs. (6531 kg)
VT. OF ROPES: 0.243 lbs/ft (13.616 g/cm)
TRAVEL CABLE WT: 0.228 lbs/ft (13.393 g/cm)

DRIVE/TRAIN:
TYPE: Winding Drum
MOTOR: 3 HP with Integrated Brake
TRANSMISSION: Ultra-Low Vibration 3-Stage Right Angle Helical-Bevel Drive
MOTOR CONTROL: Pre-Programmed Variable Freq. Drive
DOOR INTERLOCKS: Honeywell RDI-G-LSB certified in compliance with ASME A17.1 Sections 2.12.4.3
PIT/FLOOR LOAD: (4 of Hoistwayx143) + (4 of Floorx340) + 3100 Dead Load (lbs)

PIT FLOOR TO SUPPORT LOAD OF: 3170 Kg
IMPACT LOAD: 3380 Kg
[7491 lbs]

LANDING CHART

	LANDING 1	LANDING 2	LANDING 3	LANDING 4	LANDING 5	LANDING 6
DOOR TYPE	SWING	DOOR SWING	DOOR	NA	NA	NA
DOOR SET SIZE	BT SWING	BT SWING	NA	NA	NA	NA
DOOR TYPE	HONEYWELL	HONEYWELL	NA	NA	NA	NA
LOCK TYPE	NO	NO	NA	NA	NA	NA
HALL CALL KEY SWITCH	NO	NO	NA	NA	NA	NA
FLOOR MARKING	NO	NO	NA	NA	NA <td NA	
LANDING CONFIGURATION	PIT	BALKONY	NA	NA	NA	NA

OPTIONS:
BUFFER SPRING: No
COLOR: Texture Black (std) PK629A365

ENTRANCE SIDE LEGEND

SIDE D
SIDE B
SIDE C
SIDE A
PLATFORM
TOP LEVEL

DATA SHEET

CUSTOMER: _____
PROJECT: _____
ADDRESS: _____

OFFICE USE ONLY:
CONSTRUCTION REGION STAMP: 1.5
DATE: 07/31/2018
COMPLETED BY: S.C.
JOB No.: VL-TYPE 25 OF 6

Part No. **VUELIFT**
Report No. **30009087**

SHEET No. **25** OF **6**

Figure 22: Pit cutout/thru-floor cutout (octagonal glass, type 2)

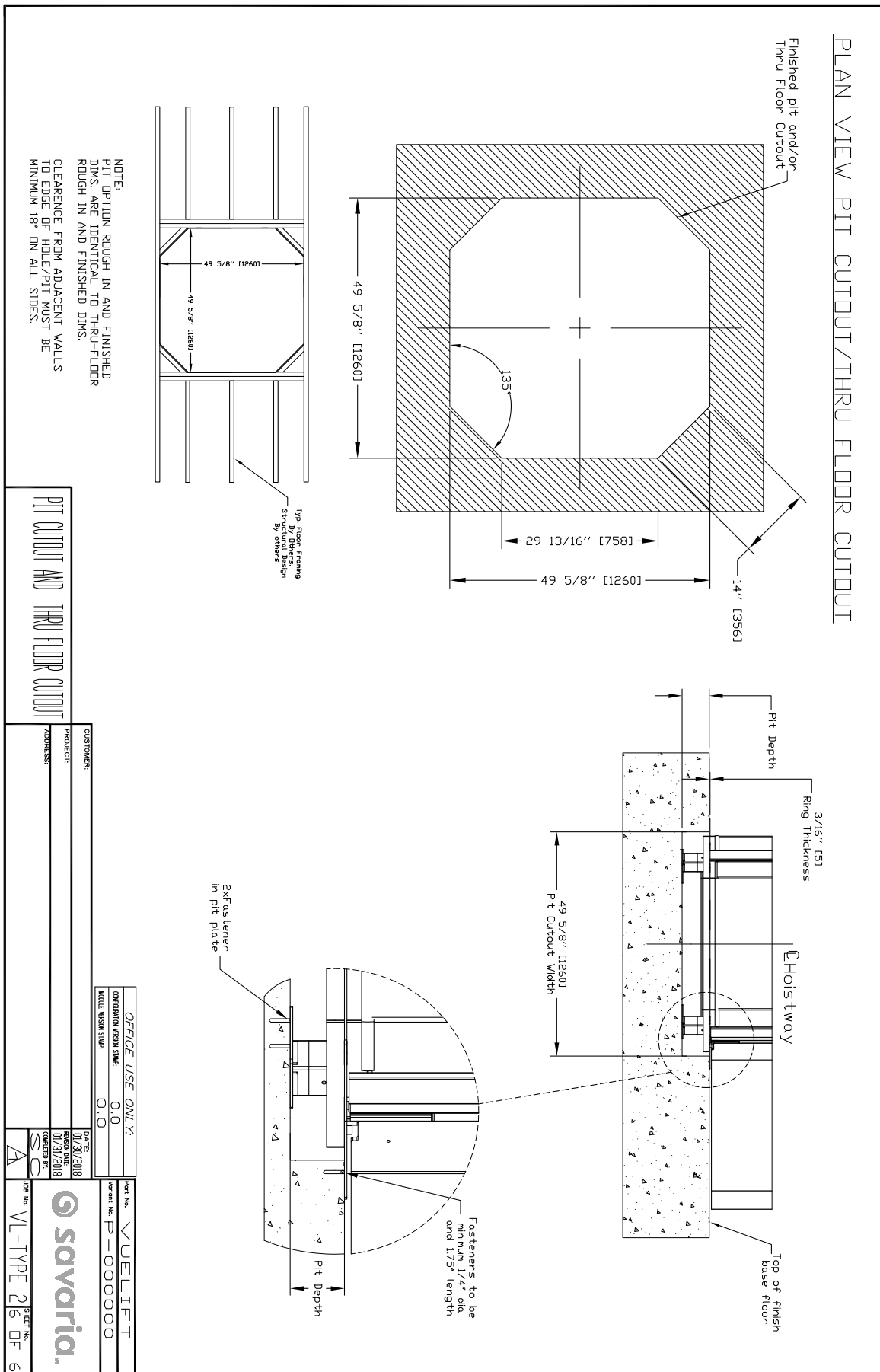
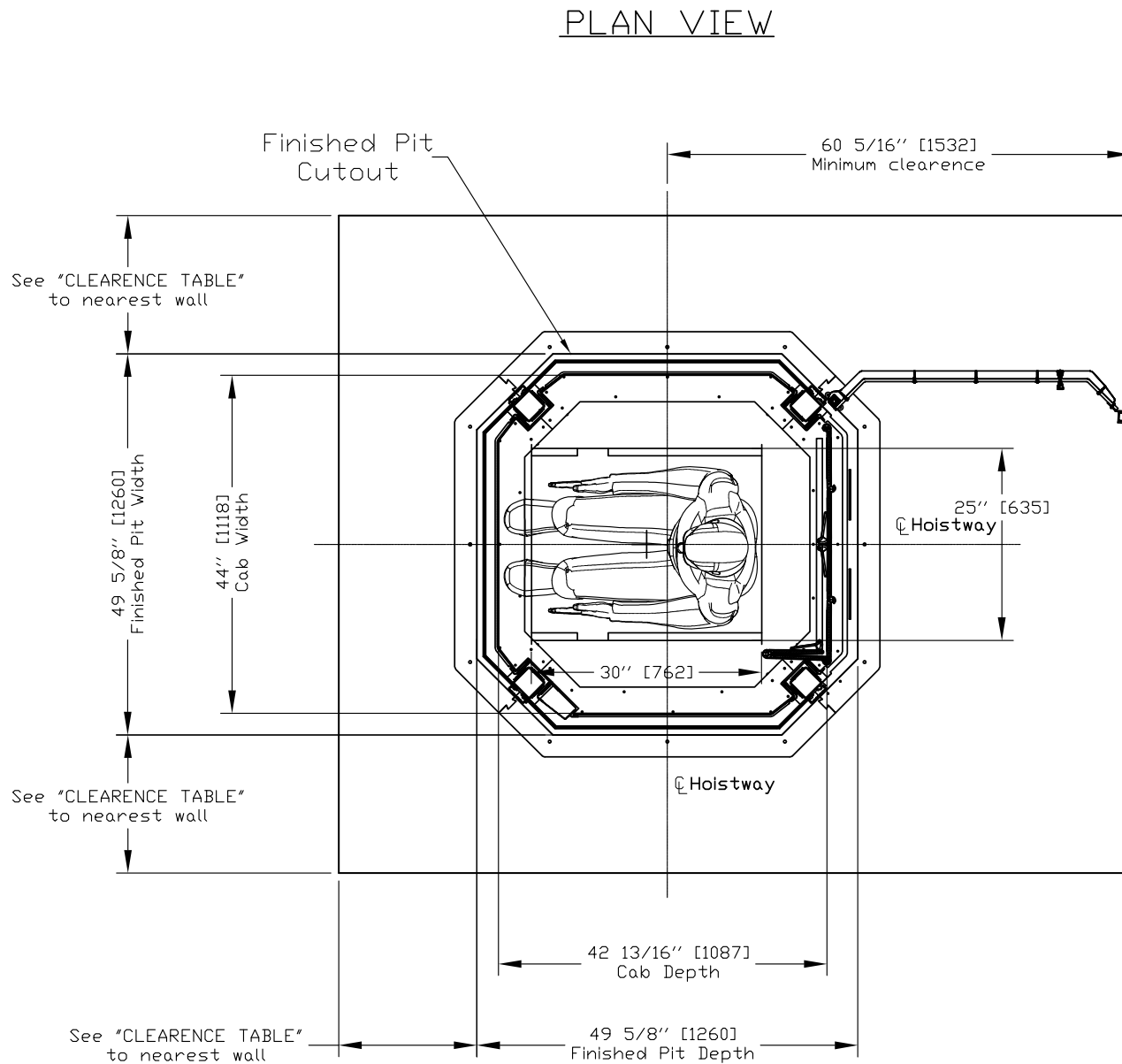
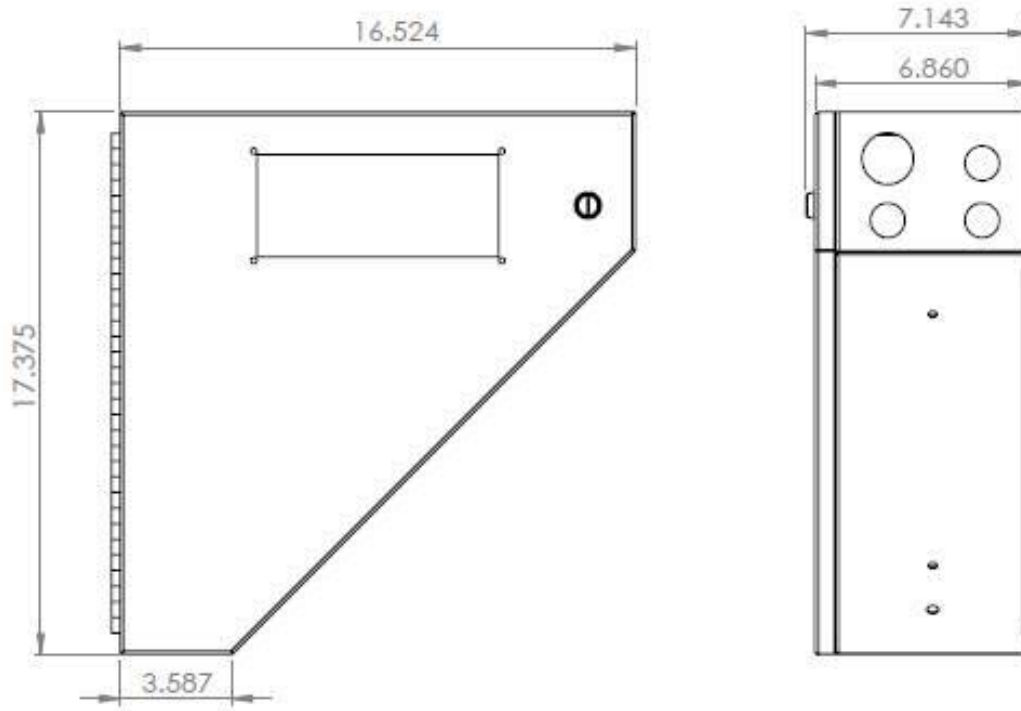

Figure 23: Wheelchair plan view (octagonal)



Notes: * No footrest used on wheelchair.
 ** Size may vary. Please review with your local dealer the availability of a true size template to review if chair will fit.

Figure 24: Controller box and UPS dimensions

NOTE: A remote controller cannot be more than 50 feet (15.24 meters) away from the top of the unit in order for the cable to reach.

Vuelift

Residential Elevator PLANNING GUIDE

Part No. 001123
Rev. 14-m06-2018

Copyright © 2018

Savaria Concord Lifts, Inc.
www.savaria.com

Sales
2 Walker Drive
Brampton, Ontario L6T 5E1
Canada
Tel: (905) 791-5555
Fax: (905) 791-2222
Toll Free: 1-800-661-5112

