



Infinity & Infinity HD

RESIDENTIAL ELEVATORS

Planning Guide

Applicable Codes:

ASME A17.1/CSA-B44

Safety Code for Elevators and Escalators
Section 5.3 – Private Residential Elevators

Part No. 000783
07-m03-2016

Purpose of this guide

This planning guide is designed to assist architects, contractors and lift professionals in planning for an Infinity/Infinity HD Residential Elevator to meet the requirements of the following codes:

- ASME A17.1/CSA B44 2000, Section 5.3
- ASME A17.1/CSA B44 2004, Section 5.3
- ASME A17.1 2004, Addendum 2005, Section 5.3
- ASME A17.1/CSA B44 2007, Section 5.3
- ASME A17.1/CSA B44, Addendum 2008, Section 5.3
- ASME A17.1/CSA B44 2010, Section 5.3
- ASME A17.1/CSA B44 2013, Section 5.3
- ASME A17.1 1996, Part 5

We strongly recommend that you contact the code authority having jurisdiction in the area where the lift will be installed to become familiar with all the legal requirements governing the installation and use of lifts in commercial applications. It is extremely important for you to know and adhere to all regulations pertaining to the installation and use of lifts.

How to use this guide

- 1 Determine your client's intended use of the lift.
- 2 Determine the local code requirements.
- 3 Determine the site installation parameters.
- 4 Determine the cab type and hoistway size requirements.

NOTE: If the Infinity/Infinity HD also has Auto Slim Doors, do not refer to the tables on pages 6 and 7; refer instead to Appendix A.

- 5 Plan for machine room and electrical requirements.

History

January 10, 2011 - Initial release

February 23, 2011

- Added note to step 4 above, under "How to use this guide"
- Added "Auto slim doors" to "Options" in specification table on page 5
- Added IMPORTANT note on page 10 and pages 12 through 23
- Condensed drawings to two per page to reduce book size (pages 12 through 23)
- Added Appendix A with Auto Slim Doors planning information

April 19, 2011 - Updated Auto Slim Door entrance assembly and elevation drawings in Appendix A

August 12, 2011 - Revised Auto Slim Door entrance assembly drawings in Appendix A

September 15, 2011 - Revised Auto Slim Door entrance assembly drawings in Appendix A

August 30, 2012 - Revised Auto Slim Door elevation and plan view drawings in Appendix A

November 6, 2012 - Added door recommendation on page 31

July 9, 2013 - Added Noise Level to specifications table on page 5

March 12, 2014 - Revised specifications table on page 5

November 5, 2014 - Revised Applicable Codes on page 3

December 9, 2014 - Revised all drawings on pages 12 to 23 and in Appendix A on pages 46, 48, 50, 52, 54, and 56

May 25, 2015 - Revised tables on page 42

August 7, 2015 - Added COP and Hall Call dimensions on pages 43 and 44

August 31, 2015 - Revised load capacity in specs table on page 5

September 24, 2015 - Added Daily Cycle to specs table on page 5

March 7, 2016 - Removed copyright from cover page; Savaria Corporation back to Savaria Concord Lifts, Inc.

IMPORTANT NOTICE

This Planning Guide provides nominal dimensions and specifications useful for the initial planning of a project. Before beginning actual construction, make sure you have the installation (shop) drawings customized with specifications and dimensions for your specific project.

Lift configurations and dimensions are in accordance with our interpretation of the standards set forth by the codes listed on the front cover of this Planning Guide. Please consult Savaria or the authorized Savaria dealer in your area for more specific information pertaining to your project, including any discrepancy between referenced standards and those of any local codes or laws.

The dimensions and specifications in this Planning Guide are subject to change (without notice) due to product enhancements and continually evolving codes and product applications.

Visit our website www.savaria.com for the most current Infinity drawings and dimensions.

Product description

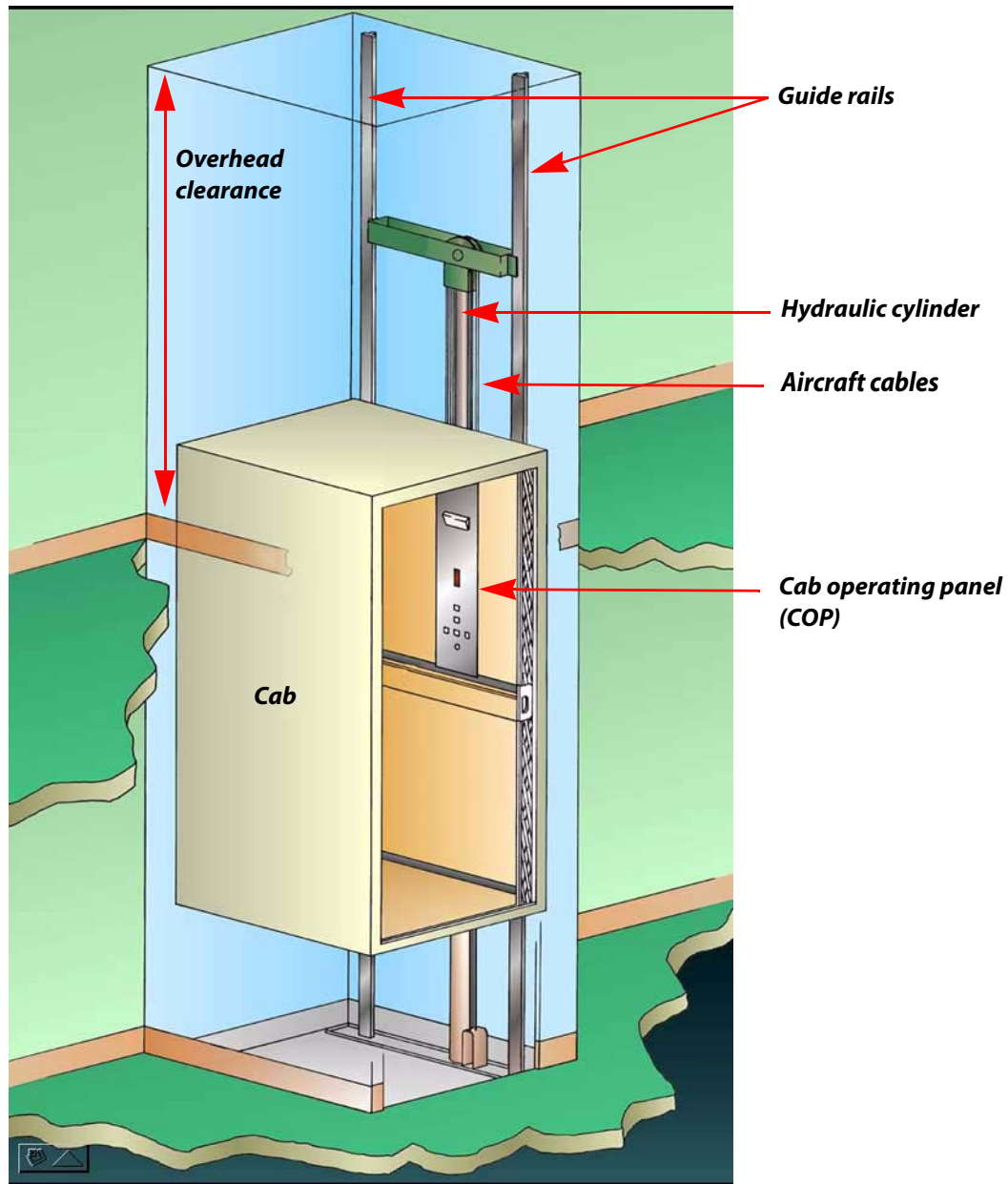

INFINITY IN HOISTWAY

Meets Americans with Disabilities Act (ADA) requirements

The Infinity and Infinity HD meet the requirements of the ADA Accessibility Guidelines as a means to provide public building access.

Design assistance

With over 30 years of experience, Savaria has the expertise to provide solutions to practically every design challenge you face. Please call our Customer Service Department for professional advice at (800) 661-5112 or (905) 791-5555.

Infinity/Infinity HD specifications

Specification type	Specification data
Load capacity	Infinity: 750 lb (341 kg), 950 lb (431 kg) or 1000 lb (454 kg) Infinity HD: 1400 lb (635 kg)
Rated speed	36 ft/min (0.18 m/s) nominal
Maximum travel	50 ft (15.24 m) – confirm with local code
Maximum # of stops	6 stops
Pit depth required	Infinity: 8" (203 mm) minimum up to 96" (2438 mm) Infinity HD: 12" (305 mm) minimum up to 96" (2438 mm)
Minimum overhead clearance	92" (2337 mm) for standard 80" cab; 96" (2438 mm) for 84" cab, 108" (2743 mm) for 96" cab
Power supply (circuit to be supplied by others) NOTE: Amperage may vary depending on individual units. Verify requirements prior to installation of power supply.	North American: 208 volt, three-phase, 30 amps, 60 Hz or 230 volt, single-phase, 30 amps, 60 Hz NOTE: 60 Amps for Infinity HD International: 220 volt, single-phase, 40 amps, 50 Hz
Lighting supply (circuit to be supplied by others)	North American: 115 volt, 60 Hz, 15 amps International: 220 volt, 50 Hz 15 amps
Motor	Infinity: 3 HP (2.24 kW) Infinity HD: 5 HP (3.73 kW)
Drive system	1:2 cable hydraulic
Control system	Automatic user interface Solid state electronics with relay logic motor controls
Noise level (for typical installation)	74.0 dBA; measured at a height of 1m, distance of 1m, in front of tank, in closed machine room
Daily cycle	Normal: 30 Heavy: 75 Excessive: 100 Maximum starts in 1 hour on standard installation: 15 NOTE: Please consult your Sales Representative if there a chance you may exceed these amounts.
Cab size	Infinity Type 1L, 1R, 2, 3, 4, and 5: • 36" x 48" (914 mm x 1219 mm) • 36" x 54" (914 mm x 1372 mm) • 36" x 60" (914 mm x 1524 mm) • 40" x 54" (1016 mm x 1372 mm) Infinity HD Type 1L, 1R, 2, 3, 4 and 5: • 48" x 60" (1219 mm x 1524 mm)
Cab panel finish	Solid melamine or MDF panels (standard) Unfinished veneer (optional) Solid hardwood raised panels (optional)
Hall call station and control panel finish	Clear or bronze anodized aluminum (standard) Stainless steel or brass (optional) Rectangular (standard) or oval (optional) hall stations, keyless (standard) or keyed (optional) Alpha-numeric button marking (optional)
Standard features	Anti-creep device Automatic cab on/off lighting Cab gate safety switch Car top stop switch In car digital floor indicator Clear or bronze anodized aluminum cab entrance trim and handrail Data plates, capacity tags and rope tags Emergency stop and alarm buttons Emergency battery back-up for lighting, alarm and emergency lowering Upper and lower terminal limits Magnetic floor selection, stopping and re-leveling Manual reset slack rope safety switch Mechanical rail shoring blocks Negative pressure switch Pit switch Pump run timer Rail sections (8 ft optional or 16 ft standard) Two 12 V, 4 AH, sealed no maintenance batteries with 24 V, 4 amp Smart Charge™ battery charge Unfinished plywood sub-floor Variable speed pressure compensated valve with manual lowering White ceiling with recessed incandescent down lights
Options	84" (2133 mm) or 96" (2438 mm) high cab Automatic gate operator (accordion gates only) Automatic swing door operator Phone cabinet Hose with flow control valve (15 ft, 20 ft or 25 ft) Interlocks for doors by others Keyed on/off control panel and hall stations Light screens Pipe rupture valve Buffer springs (13" pit depth minimum) Split cylinder for travel over 384" (9754 mm) Auto slim doors

Infinity/Infinity HD cab types

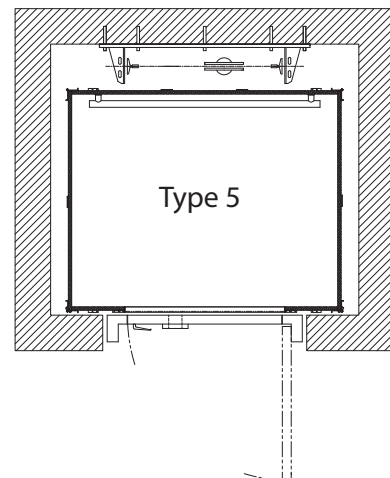
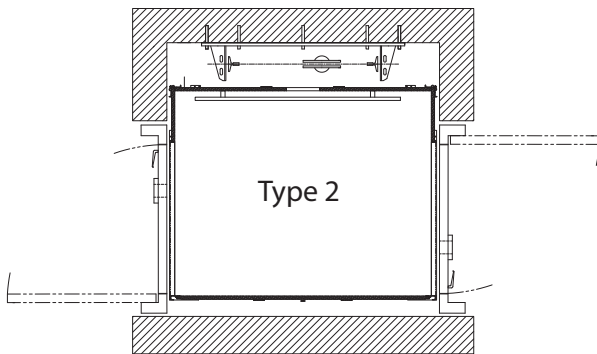
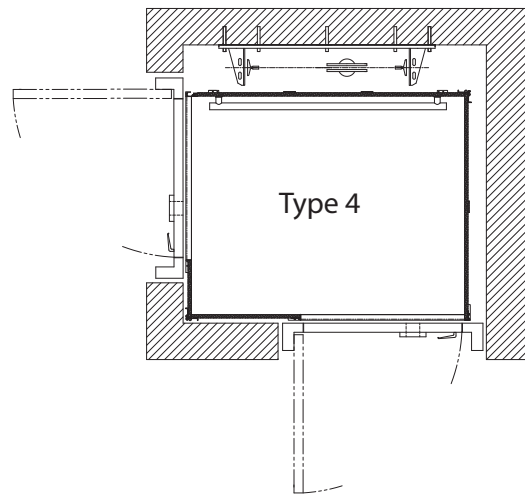
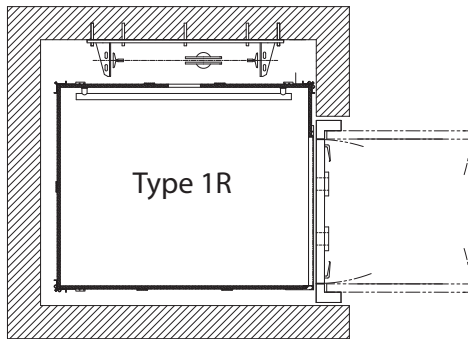
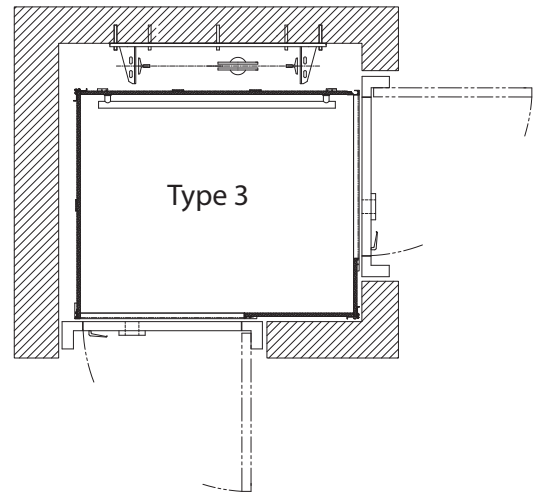
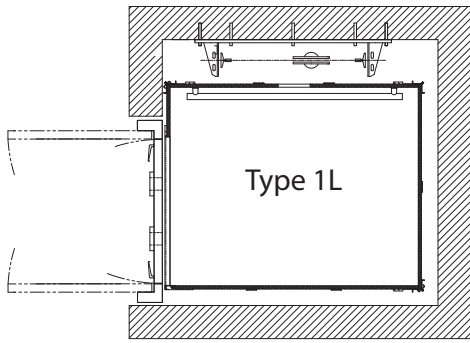

IMPORTANT

Finished hoistway dimensions must include the drywall. Determine the fire rating of the hoistway, the type and layers of sheet rock and build only off the final installation (shop) drawings specific to your project.

Machine room options

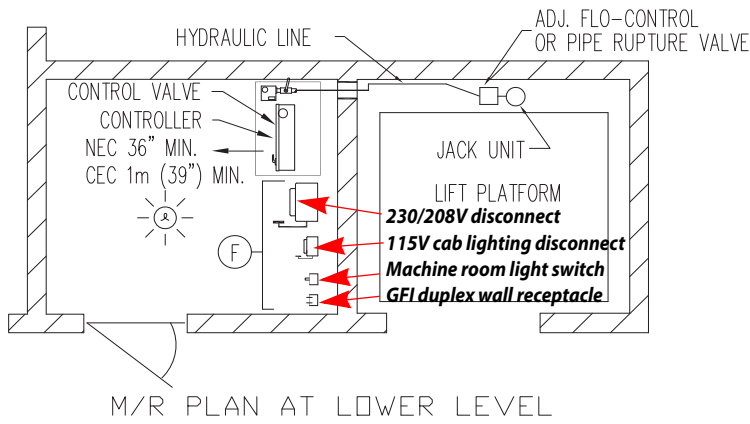

Left-hand position

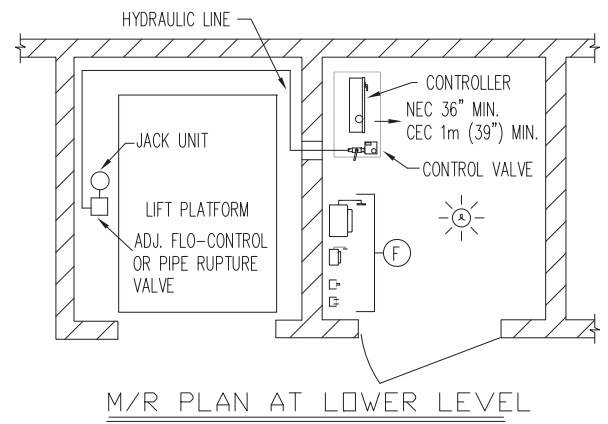

Right-hand position

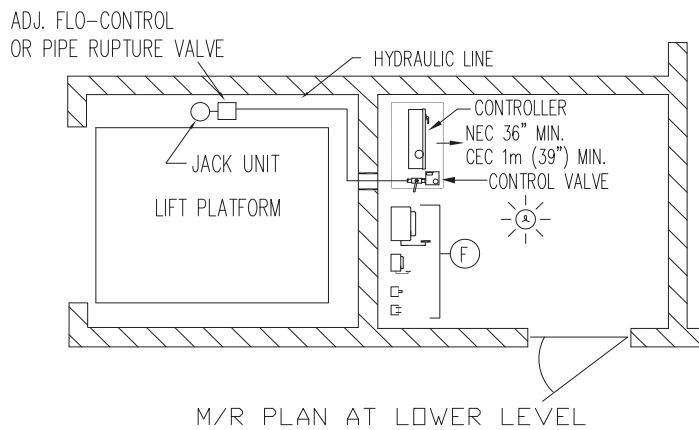

Back position

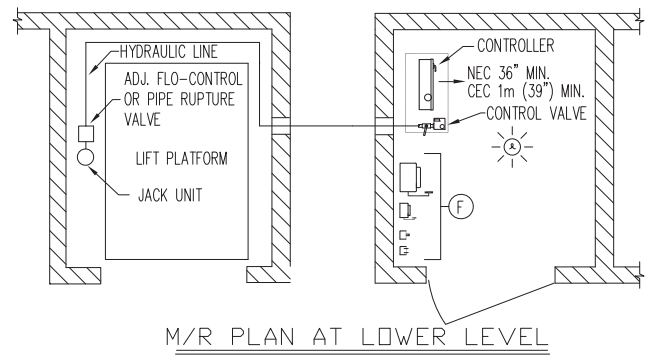

Remote position

- The machine room must be built in accordance with local, state/provincial and national codes. Adequate ventilation is required to maintain a temperature of 50°F to 100°F for output of 3600 BTU per hour.
- Power supply must be 208V three-phase with 30 amp or 230V single-phase with 40 amp dedicated circuit with equipment ground. A lockable fused disconnect with an auxiliary normally open interlock switch must be located next to the controller. The electrical circuit must terminate on the line side terminal lugs of the disconnect. It is provided and installed by others.
- The machine room lighting shall be a minimum of 19 foot candles (204 lux) at working surfaces.
- The switch for the light must be within 18" (457 mm) of the strike side of the machine room door.
- The switch, light and wiring are provided and installed by others. The light must be guarded to prevent accidental breakage of contact with the hot bulb. The switch, light, wiring and guard are provided and installed by others.
- A convenience outlet of 115V single-phase 15 amp with G.F.I. shall be located next to the light switch in the machine room (provided and installed by others).
- A telephone line circuit is to be provided and installed by others. This circuit must be connected to an outside line or a 24 hour central exchange.
- The machine room access door must be self closing, self locking with a key and spring return latch. Door and hardware are provided and installed by others. Consult local building codes for door construction.
- The machine room must be free of any pipes, wiring and obstructions not related to the operation of the lift. Provide a 4 inch conduit from the lift shaft to the remote machine room.

Machine room dimensions

IMPORTANT NOTE:
CONFIRM REQUIREMENTS WITH LOCAL CODE

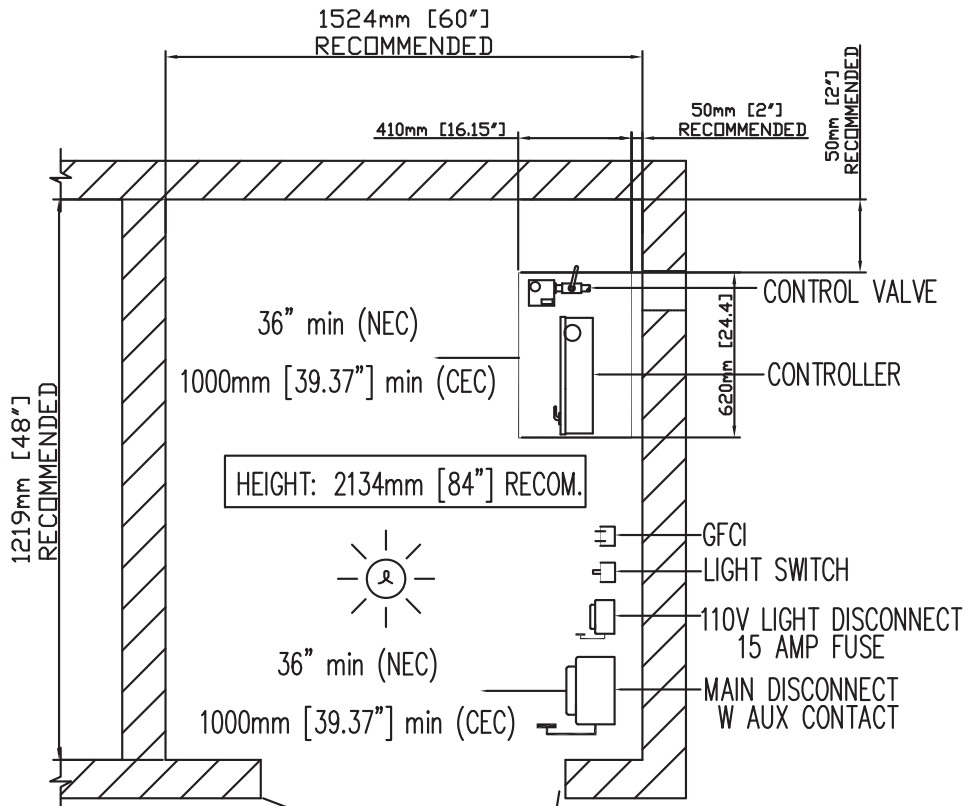

NOTE A:
POSITION OF DOORS AND COMPONENTS CAN VARY
AS LONG AS THE MINIMUM DISTANCE IN FRONT OF COMPONENTS IS RESPECTED

NOTE B:
A RACEWAY BETWEEN THE MACHINE ROOM AND HOISTWAY WILL NEED TO BE PROVIDED.
CONSULT YOUR INSTALLATION COMPANY FOR SIZE AND LOCATION

Controller tank specifications

Controller tank specifications	
Dimensions	Height: 47" (1194 mm) Width: 28" (711 mm) Depth: 17" (432 mm)
Minimum required clearance	39.37" (1000 mm)
Valve and manual lowering handle location	Inside tank
Rupture valve test	T-fitting factory installed
Tank to controller wiring	Quick connect valve and motor wiring
Controller layout	Relay board
Keyed lock to tank	Yes
Machine room required	No (with local jurisdiction approval)
Tank capacity (gal/ltr)	15-16.5 gal/57-63 ltr
Maximum dry weight (lb/kg)	147 lb/55 kg
Maximum filled weight (lb/kg)	312 lb/117 kg
Operating environment	50°F - 120°F / 10°C - 49°C
Operating volume	57 dBA

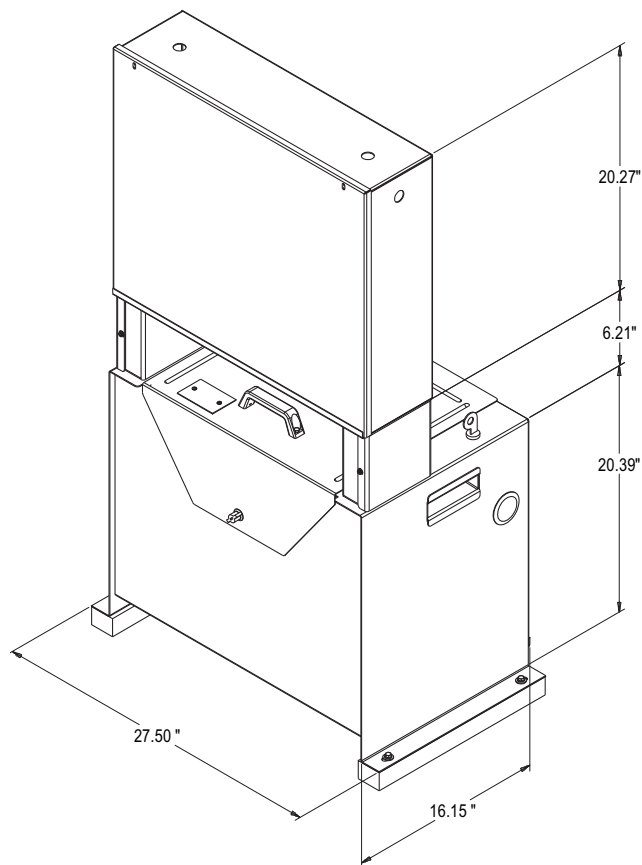

Controller tank features

- Hydraulic hose connection port on both sides of the tank
- Built-in handles on both sides of the tank
- Isolation mounting of pump motor valve assembly minimizes operating issues

Elevation view – Infinity

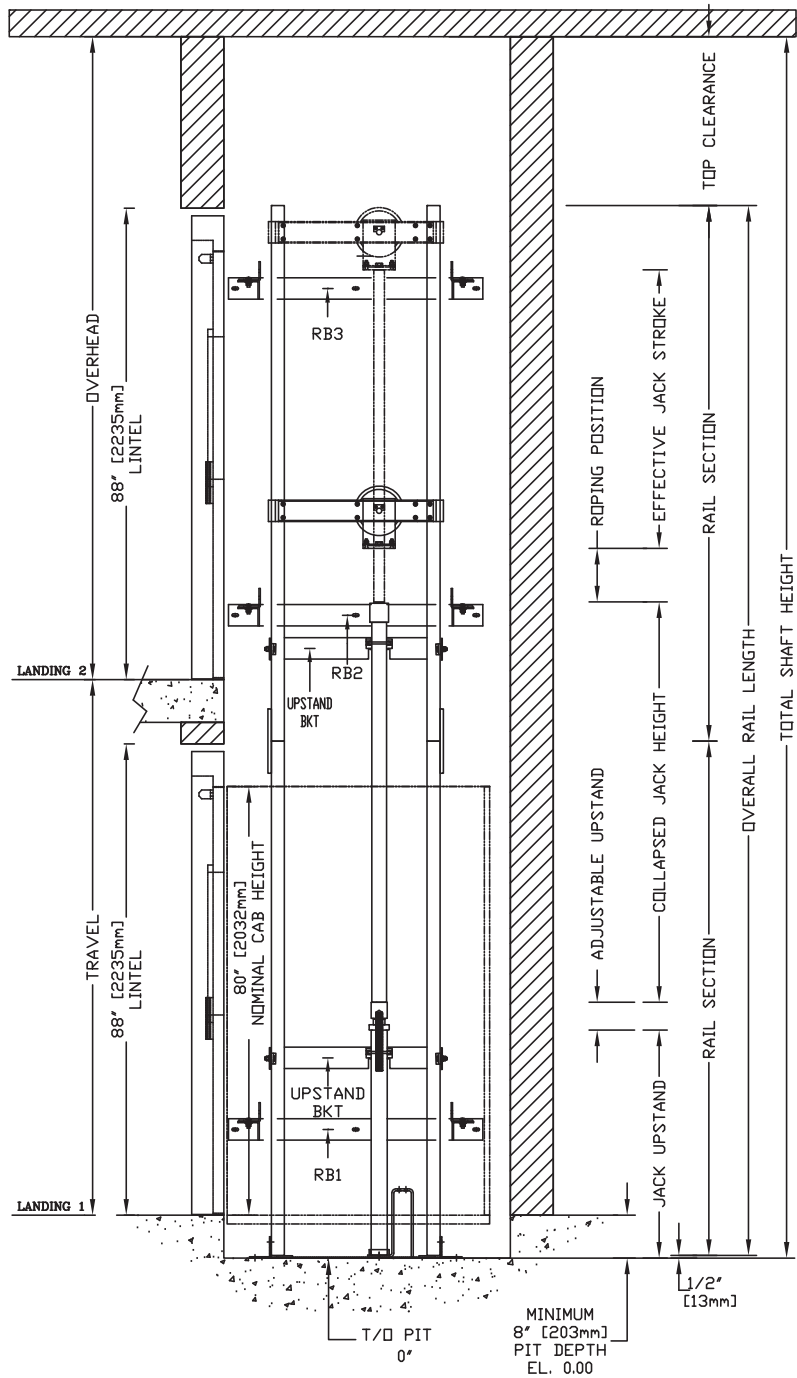

Top rail bracket (RB3): at top of hoistway (consult your Savaria representative for exact location).
 Intermediate rail bracket (RB2): 96 in (2438 mm) intervals above bottom bracket.
 Bottom rail bracket (RB1): 24 in (610 mm) above pit floor.

IMPORTANT: Always refer to your plan drawings for dimensions specific to your site.
For Infinity with Auto Slim Doors, DO NOT use the above drawing; refer to Appendix A instead.

Elevation view – Infinity HD

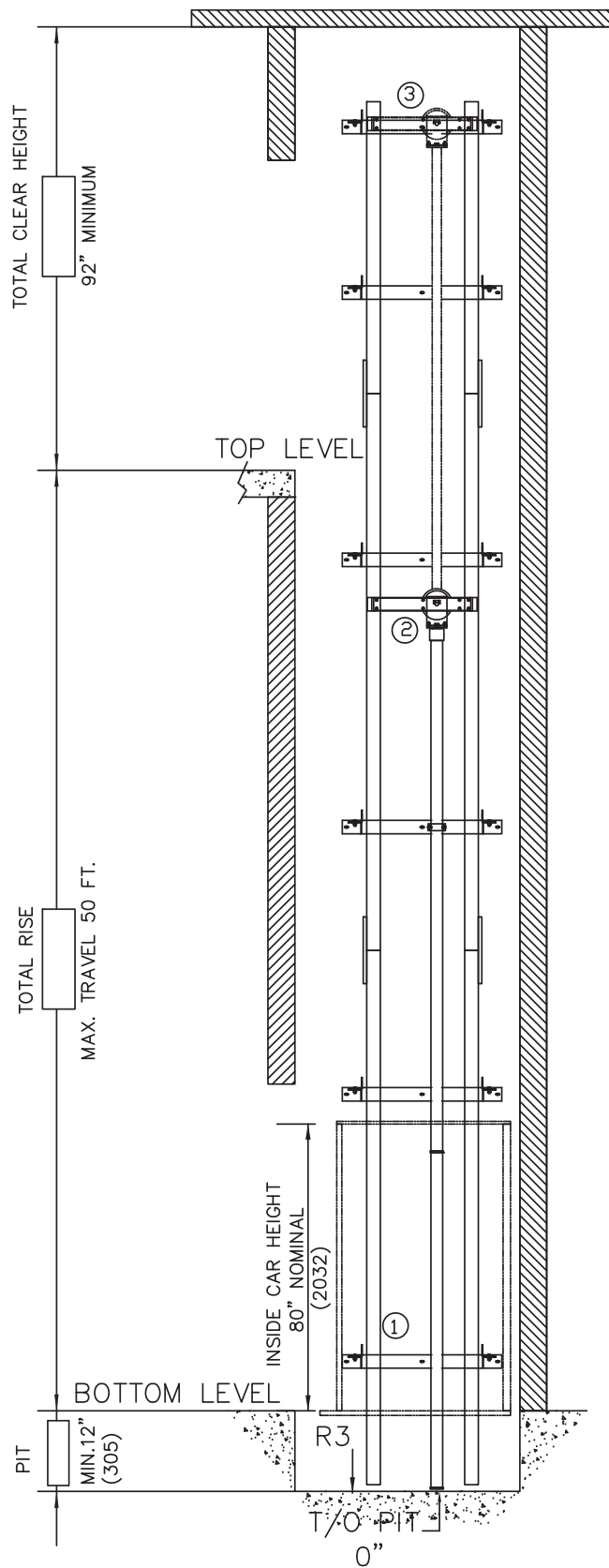

Top rail bracket (3): at top of hoistway (consult your Savaria representative for exact location).

Intermediate rail bracket (2): 48 in (1219 mm) intervals above bottom bracket.

Bottom rail bracket (1): 24 in (610 mm) above pit floor.

Plan view – Infinity 36" x 48" type 1 left-hand

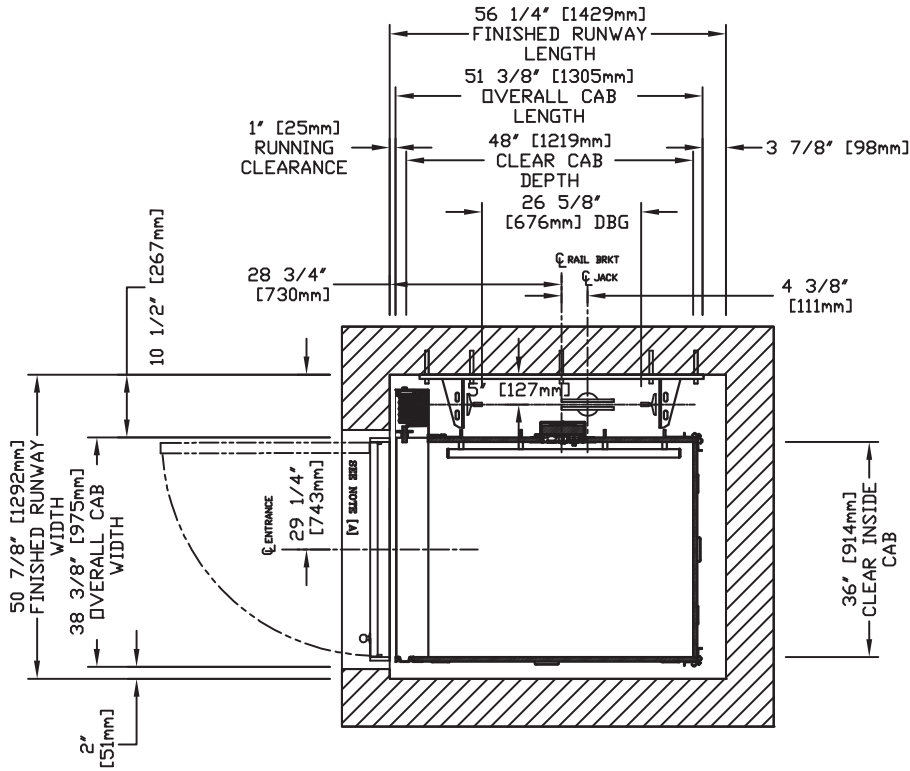

Plan view – Infinity 36" x 48" type 1 right-hand

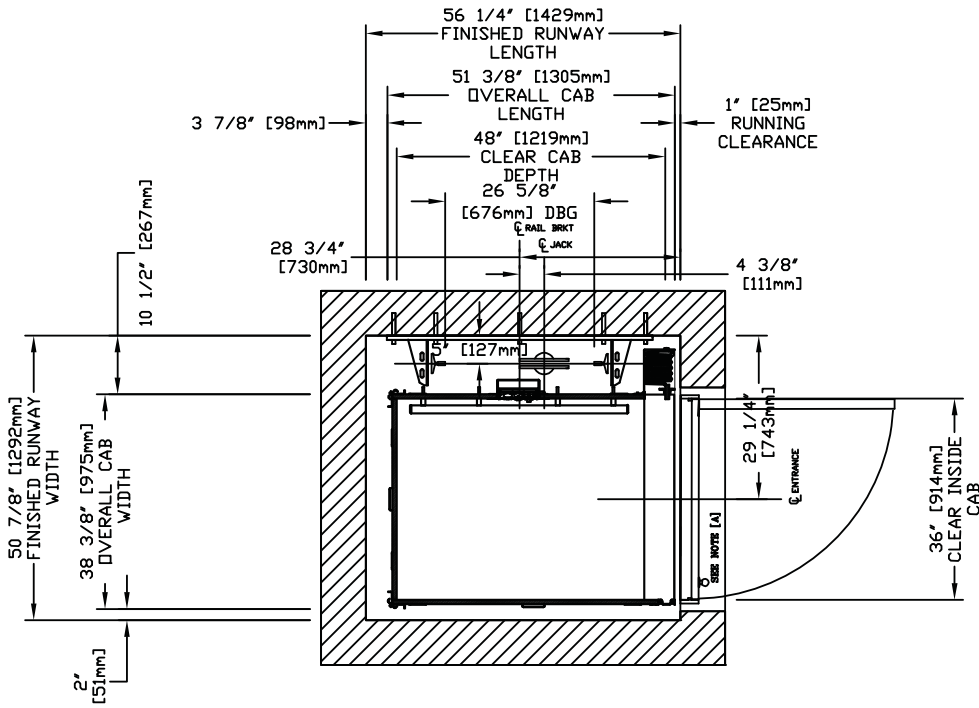

IMPORTANT: Always refer to your plan drawings for dimensions specific to your site.
For Infinity with Auto Slim Doors, DO NOT use the above drawings; refer to Appendix A instead.

Plan view – Infinity 36" x 48" type 2

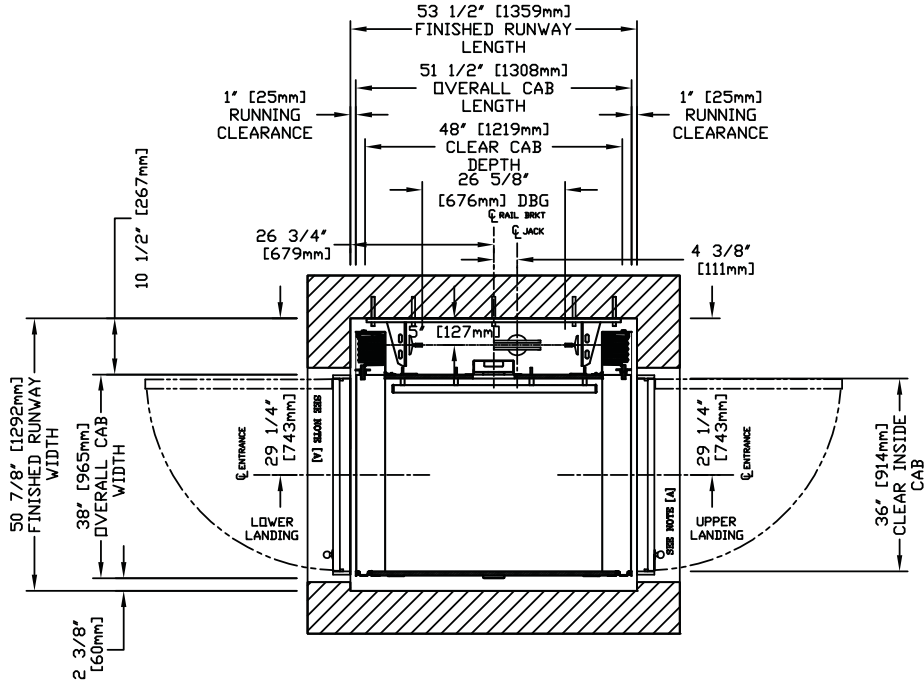

Plan view – Infinity 36" x 48" type 3

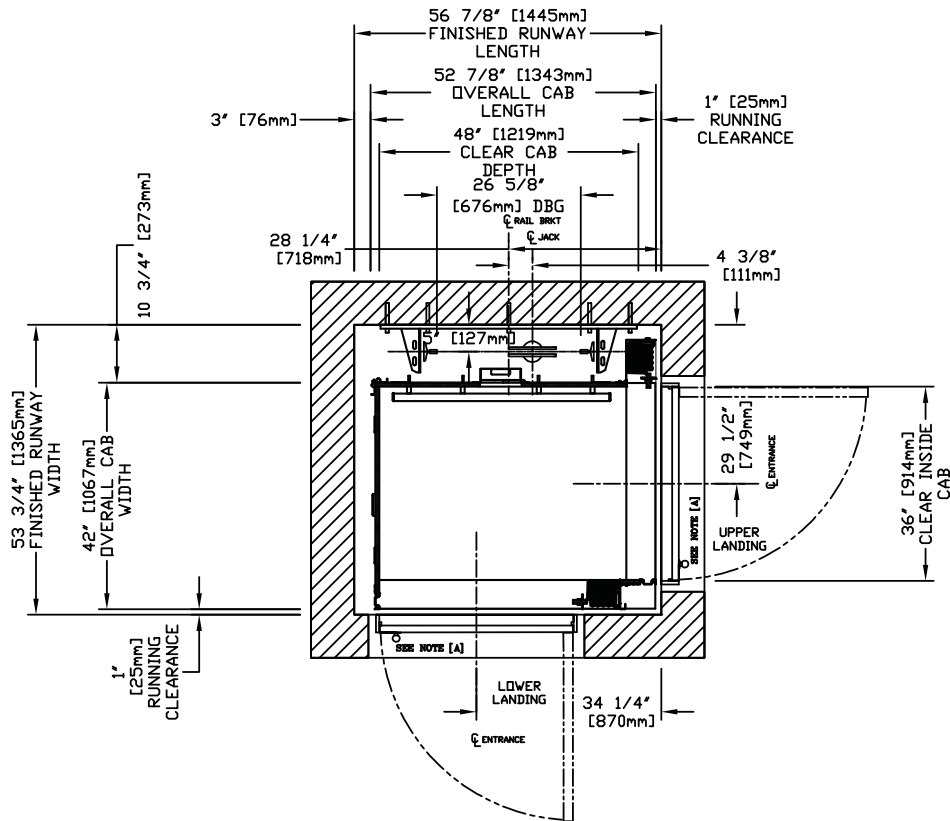

IMPORTANT: Always refer to your plan drawings for dimensions specific to your site.
For Infinity with Auto Slim Doors, DO NOT use the above drawings; refer to Appendix A instead.

Plan view – Infinity 36" x 48" type 4

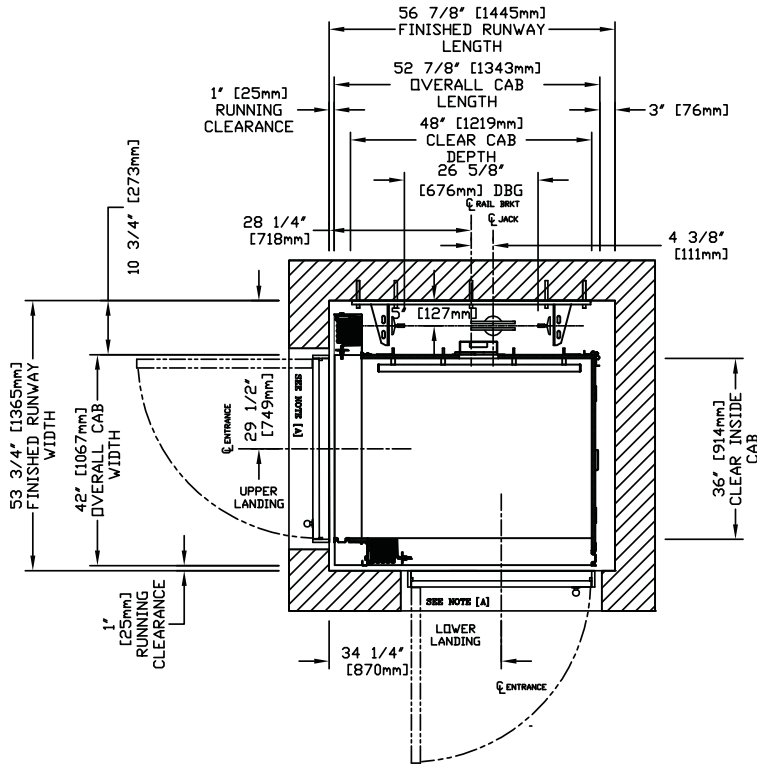

Plan view – Infinity 36" x 48" type 5

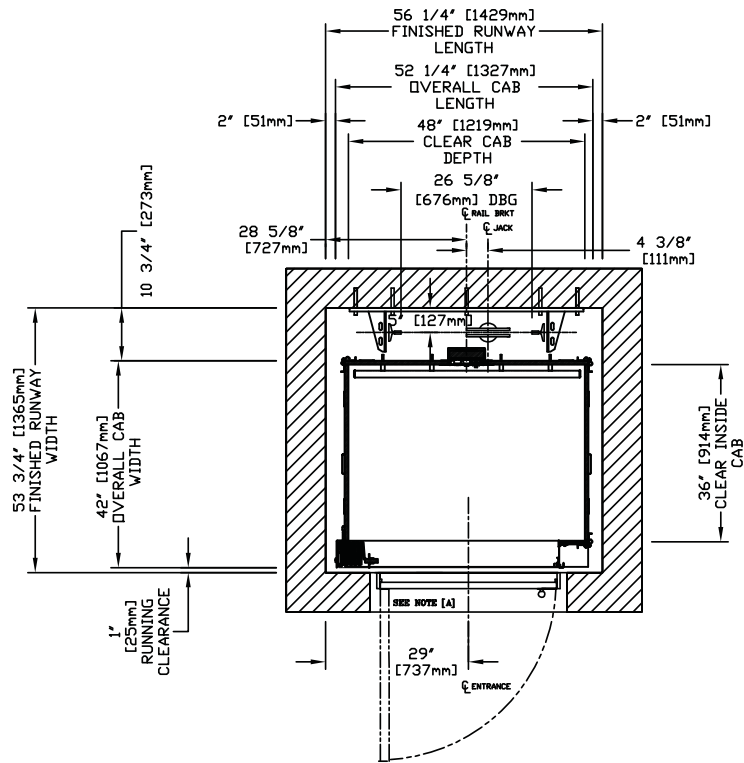

IMPORTANT: Always refer to your plan drawings for dimensions specific to your site.
For Infinity with Auto Slim Doors, DO NOT use the above drawings; refer to Appendix A instead.

Plan view – Infinity 36" x 54" type 1 left-hand

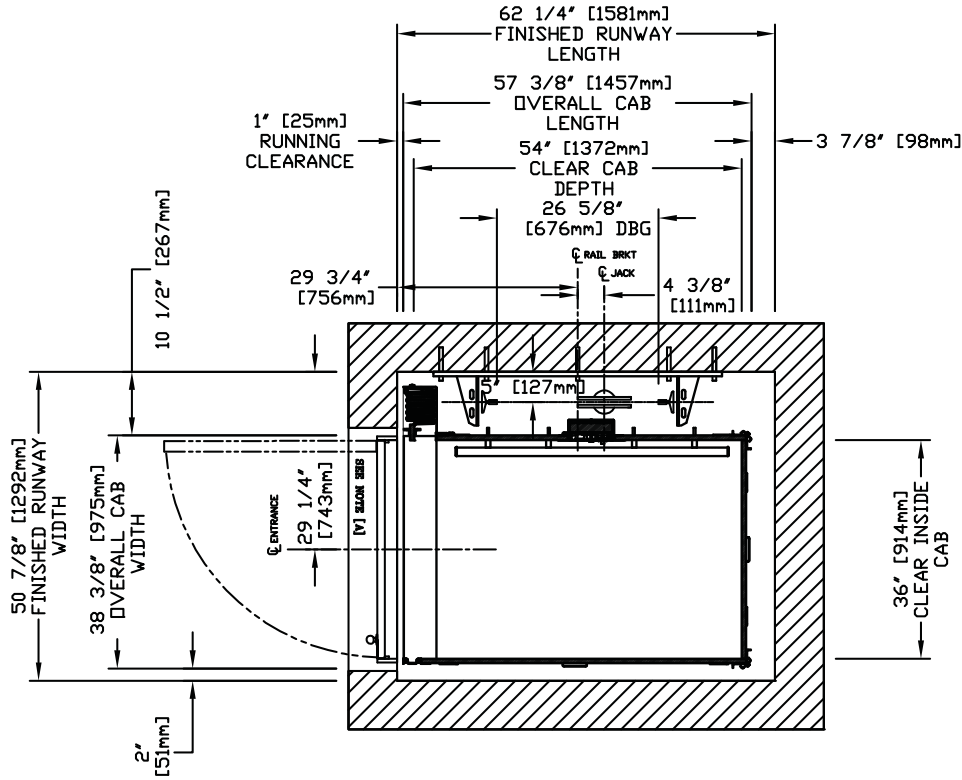

Plan view – Infinity 36" x 54" type 1 right-hand

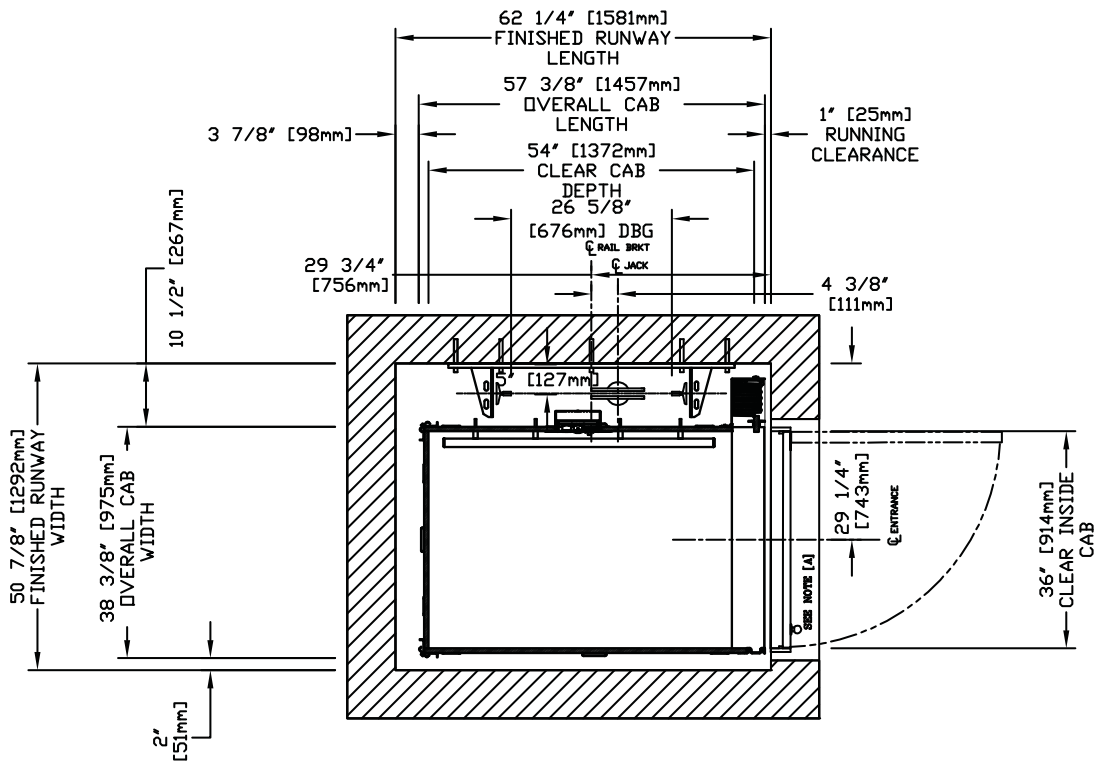

IMPORTANT: Always refer to your plan drawings for dimensions specific to your site.
For Infinity with Auto Slim Doors, DO NOT use the above drawings; refer to Appendix A instead.

Plan view – Infinity 36" x 54" type 2

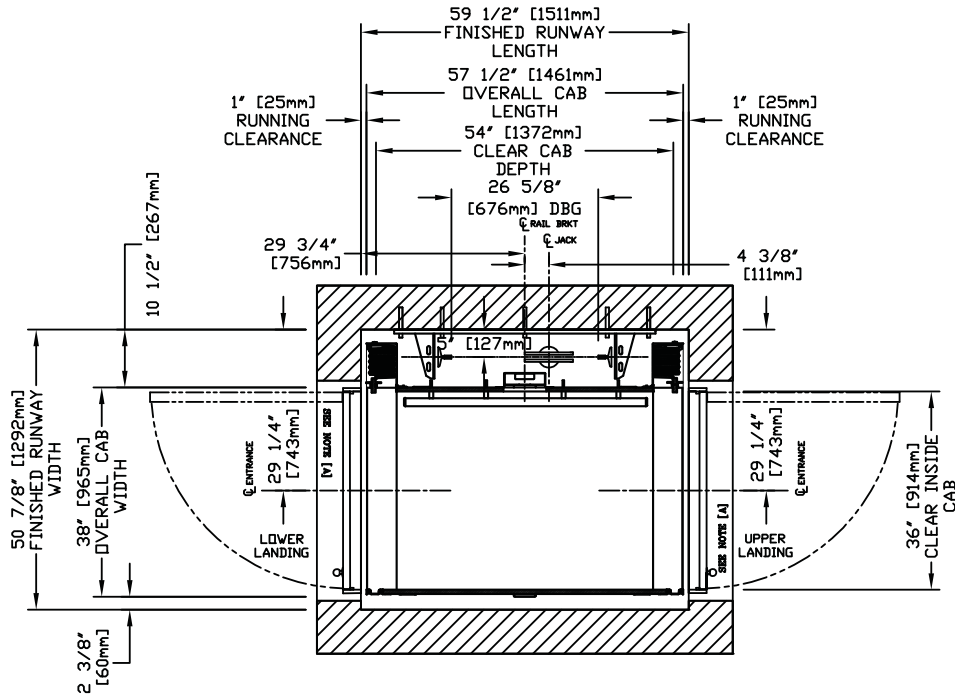

Plan view – Infinity 36" x 54" type 3

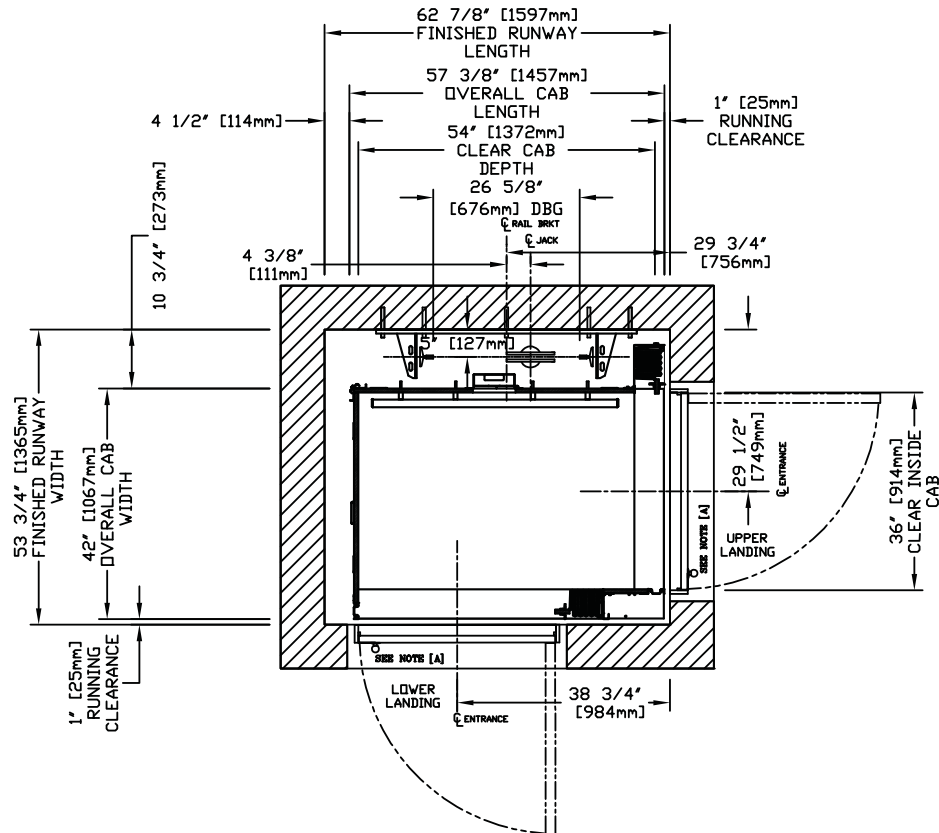

IMPORTANT: Always refer to your plan drawings for dimensions specific to your site.
For Infinity with Auto Slim Doors, DO NOT use the above drawings; refer to Appendix A instead.

Plan view – Infinity 36" x 60" type 1 left-hand

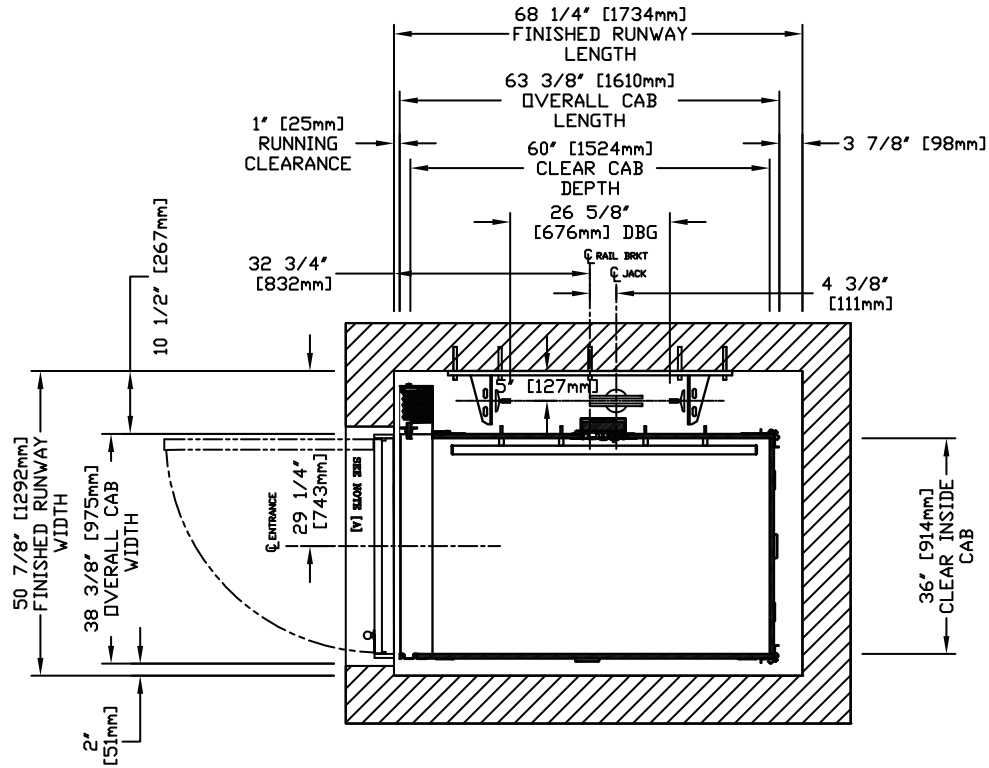

Plan view – Infinity 36" x 60" type 1 right-hand

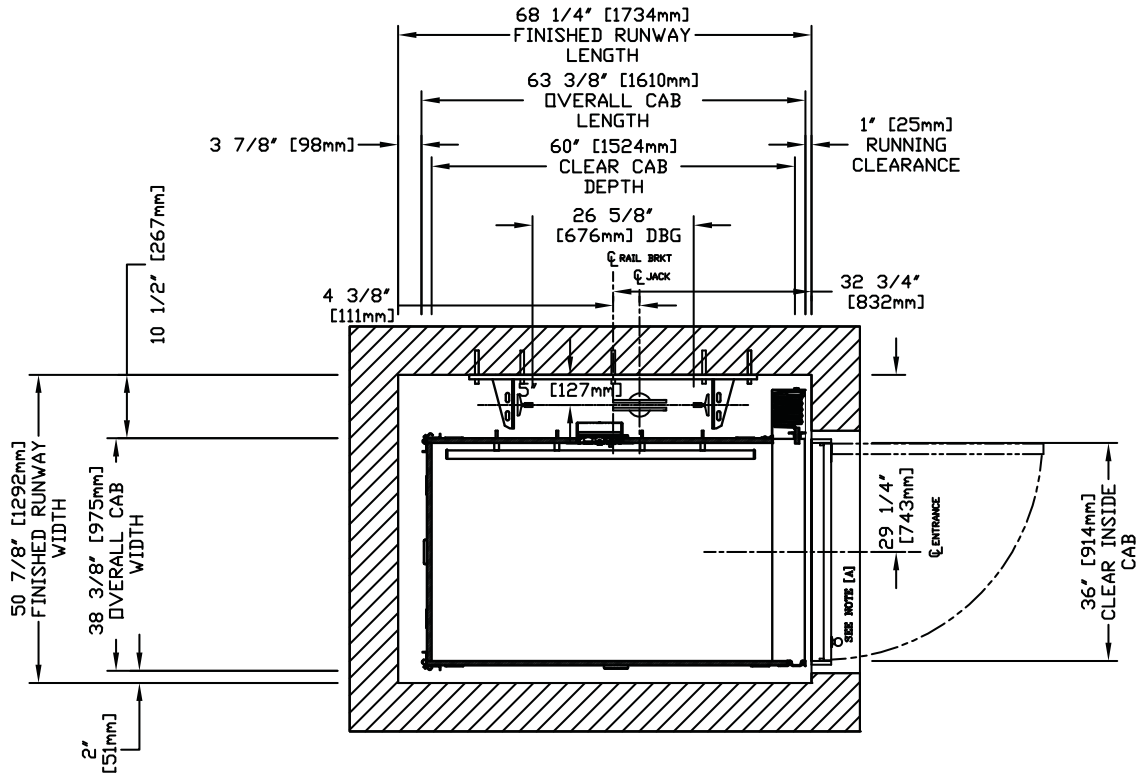

IMPORTANT: Always refer to your plan drawings for dimensions specific to your site.
For Infinity with Auto Slim Doors, DO NOT use the above drawings; refer to Appendix A instead.

Plan view – Infinity 36" x 60" type 2

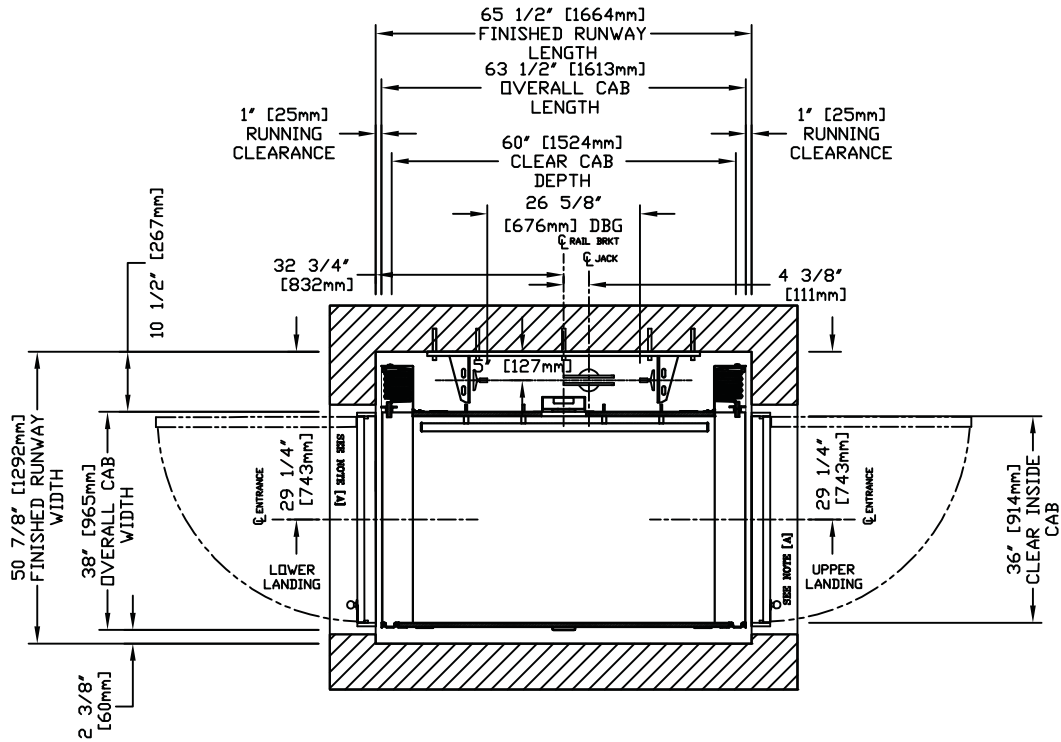

Plan view – Infinity 36" x 60" type 3

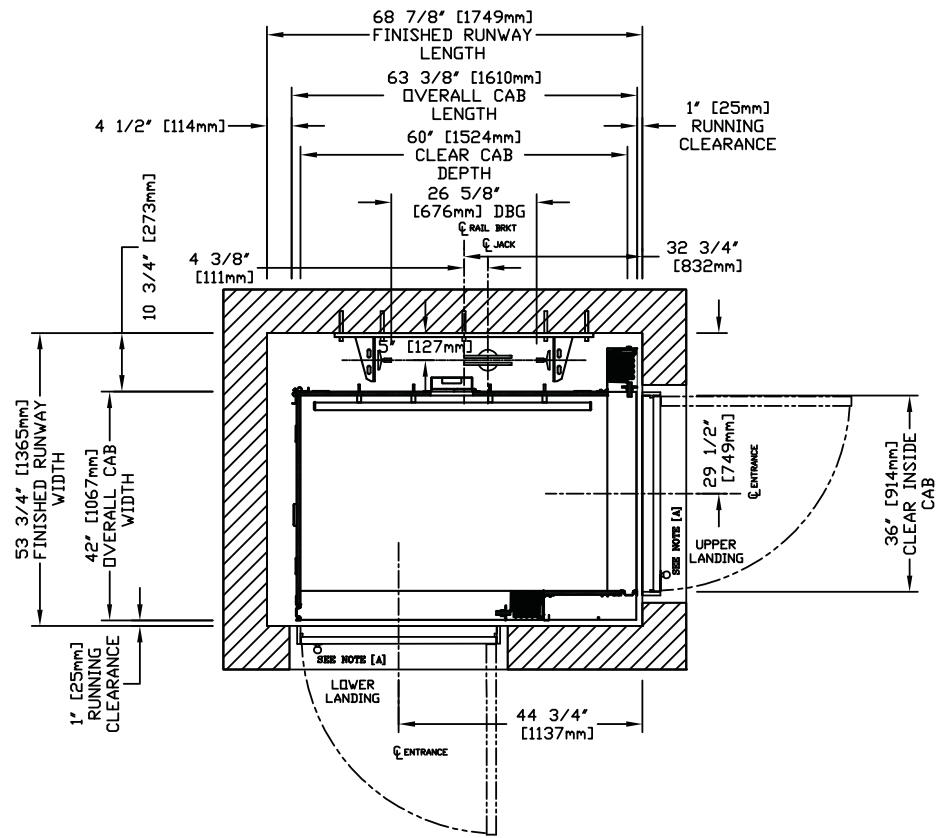

IMPORTANT: Always refer to your plan drawings for dimensions specific to your site.
For Infinity with Auto Slim Doors, DO NOT use the above drawings; refer to Appendix A instead.

Plan view – Infinity 36" x 60" type 4

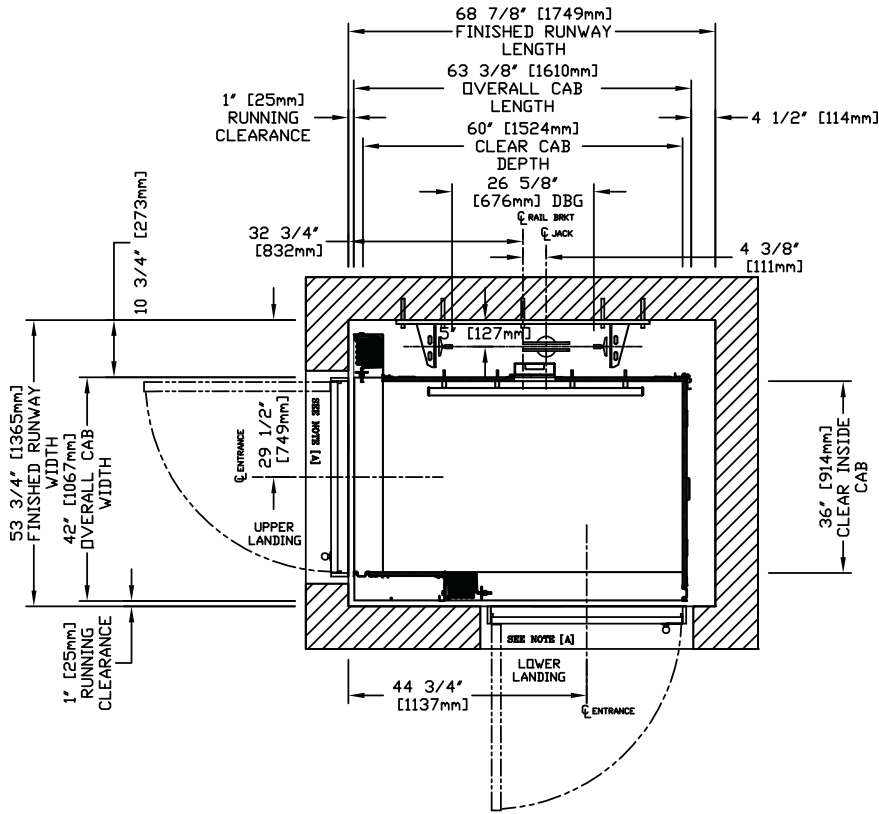

Plan view – Infinity 36" x 60" type 5

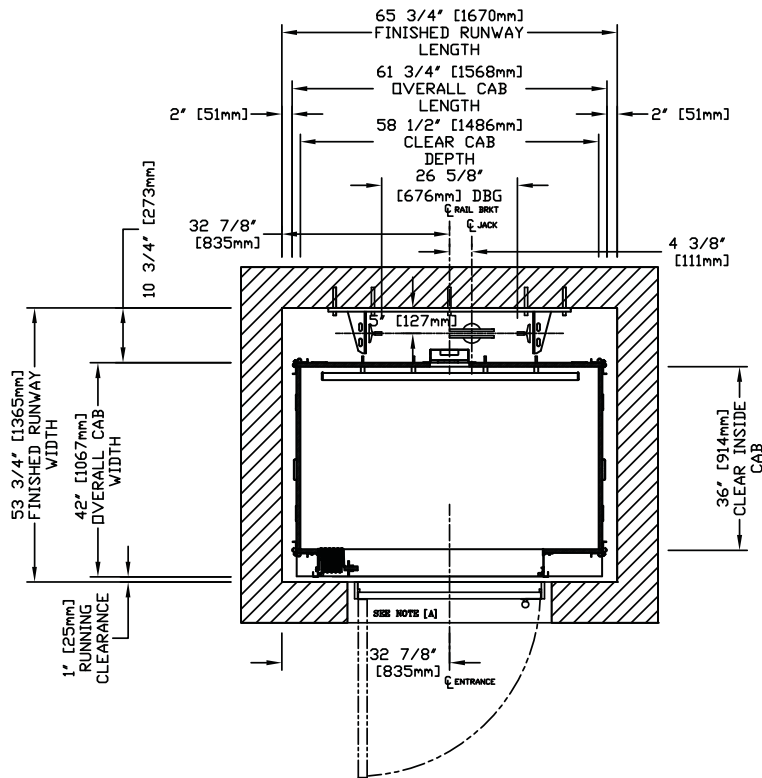

IMPORTANT: Always refer to your plan drawings for dimensions specific to your site.
For Infinity with Auto Slim Doors, DO NOT use the above drawings; refer to Appendix A instead.

Plan view – Infinity 40" x 54" type 1 left-hand

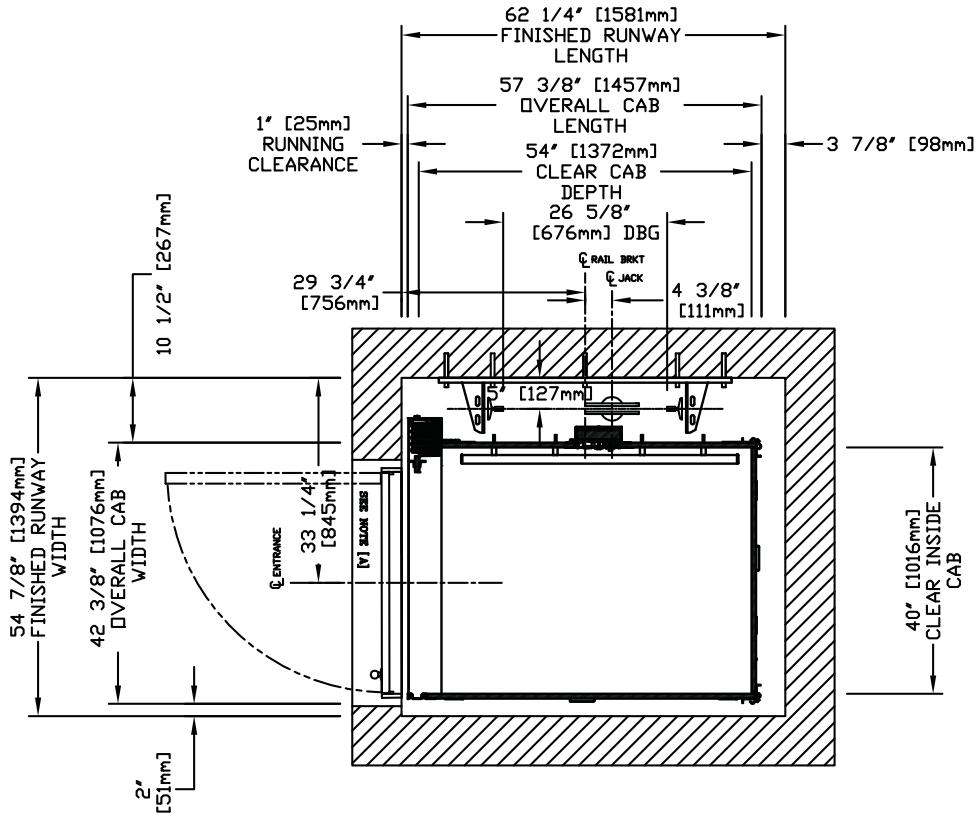

Plan view – Infinity 40" x 54" type 1 right-hand

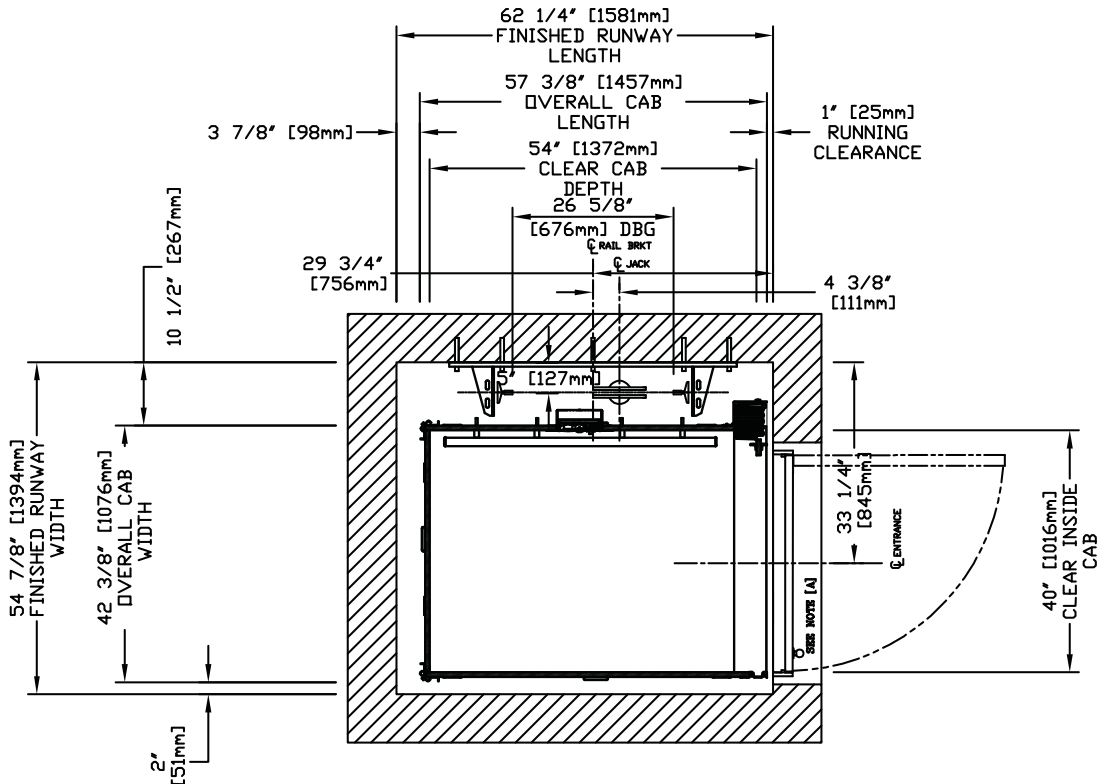

IMPORTANT: Always refer to your plan drawings for dimensions specific to your site.
For Infinity with Auto Slim Doors, DO NOT use the above drawings; refer to Appendix A instead.

Plan view – Infinity 40" x 54" type 2

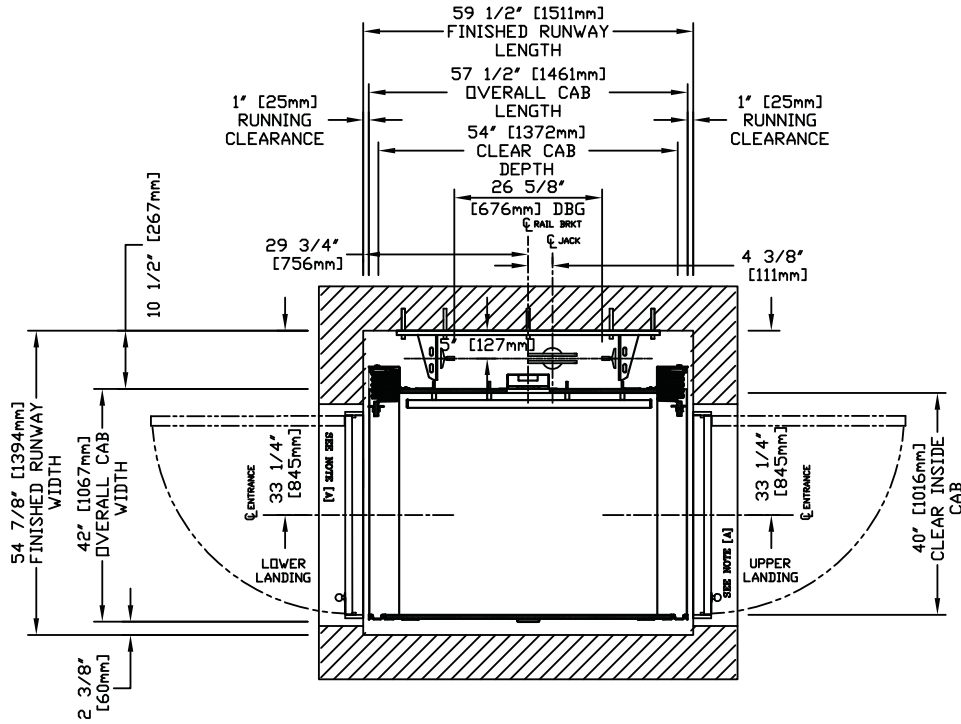

Plan view – Infinity 40" x 54" type 3

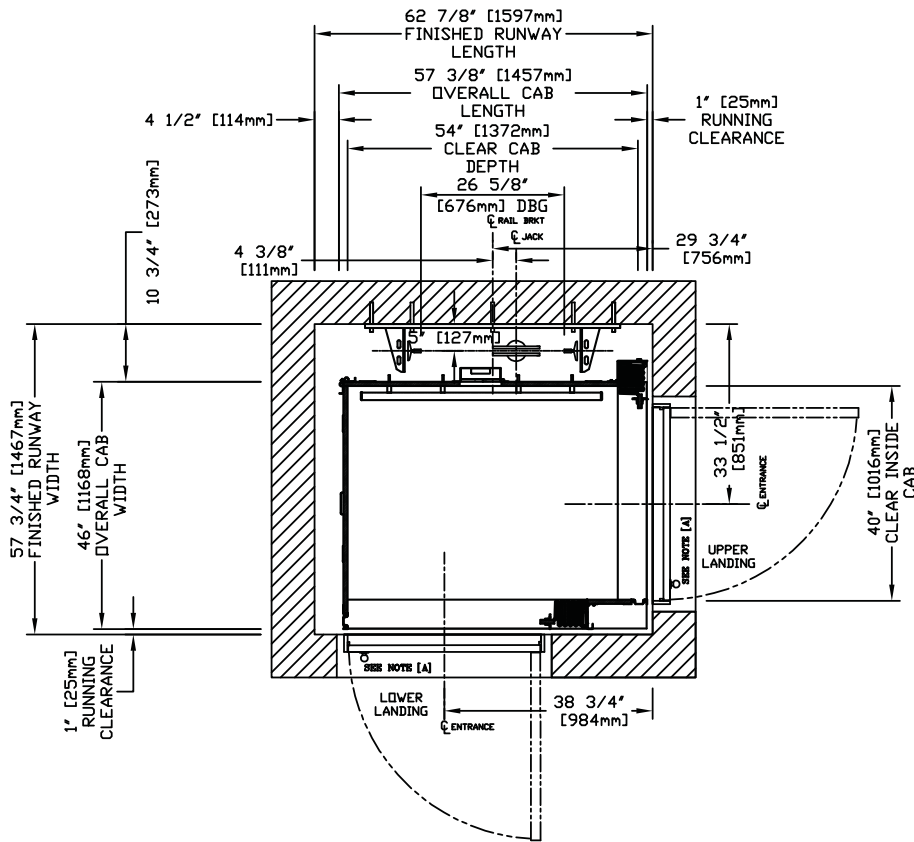

IMPORTANT: Always refer to your plan drawings for dimensions specific to your site.
For Infinity with Auto Slim Doors, DO NOT use the above drawings; refer to Appendix A instead.

Plan view – Infinity 40" x 54" type 4

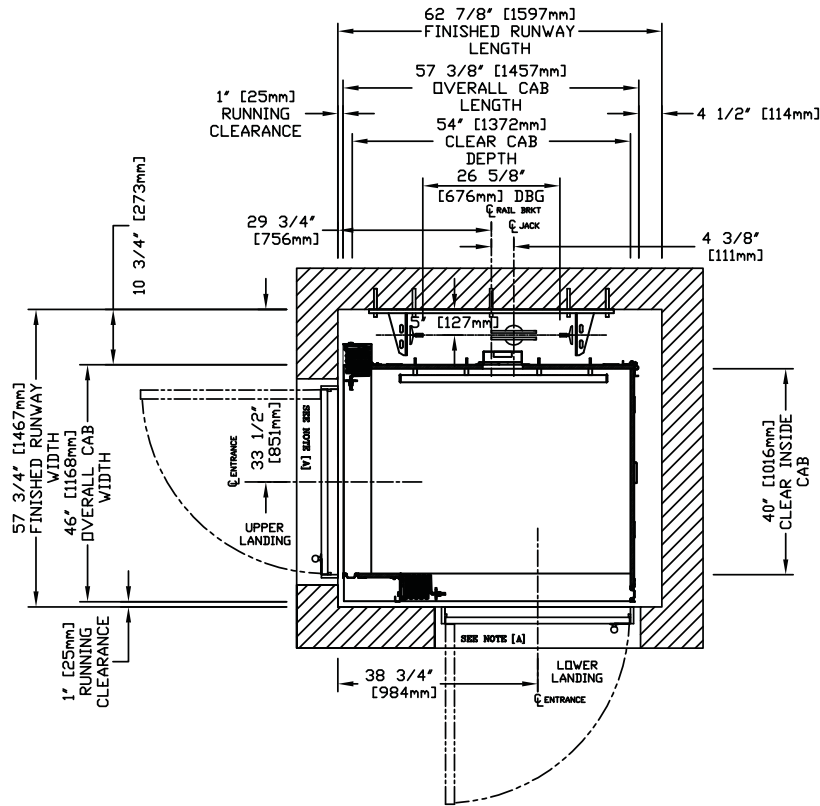

Plan view – Infinity 40" x 54" type 5

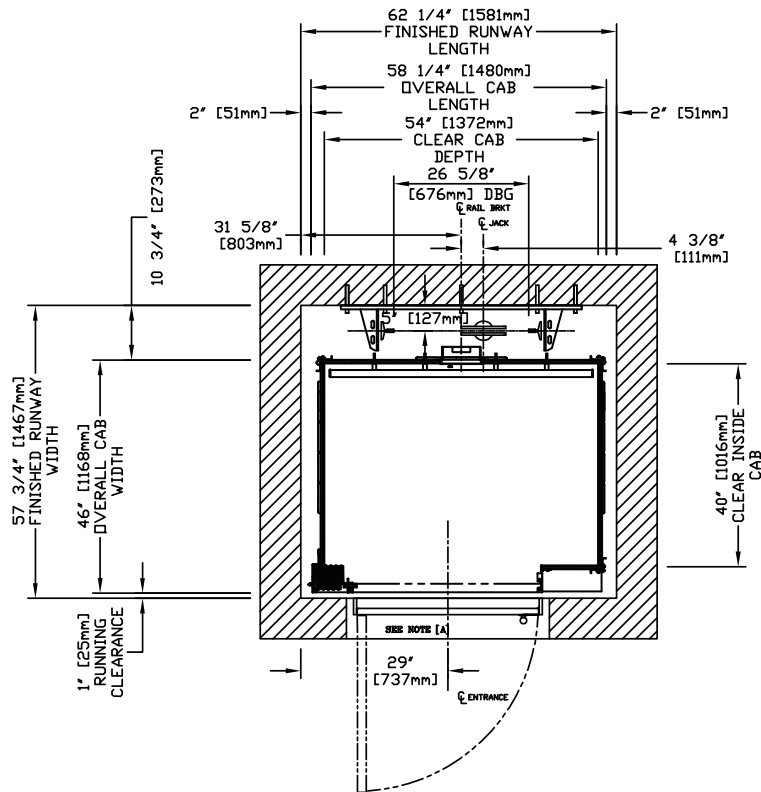

IMPORTANT: Always refer to your plan drawings for dimensions specific to your site.
For Infinity with Auto Slim Doors, DO NOT use the above drawings; refer to Appendix A instead.

Plan view – Infinity HD 48" x 60" type 1 left-hand

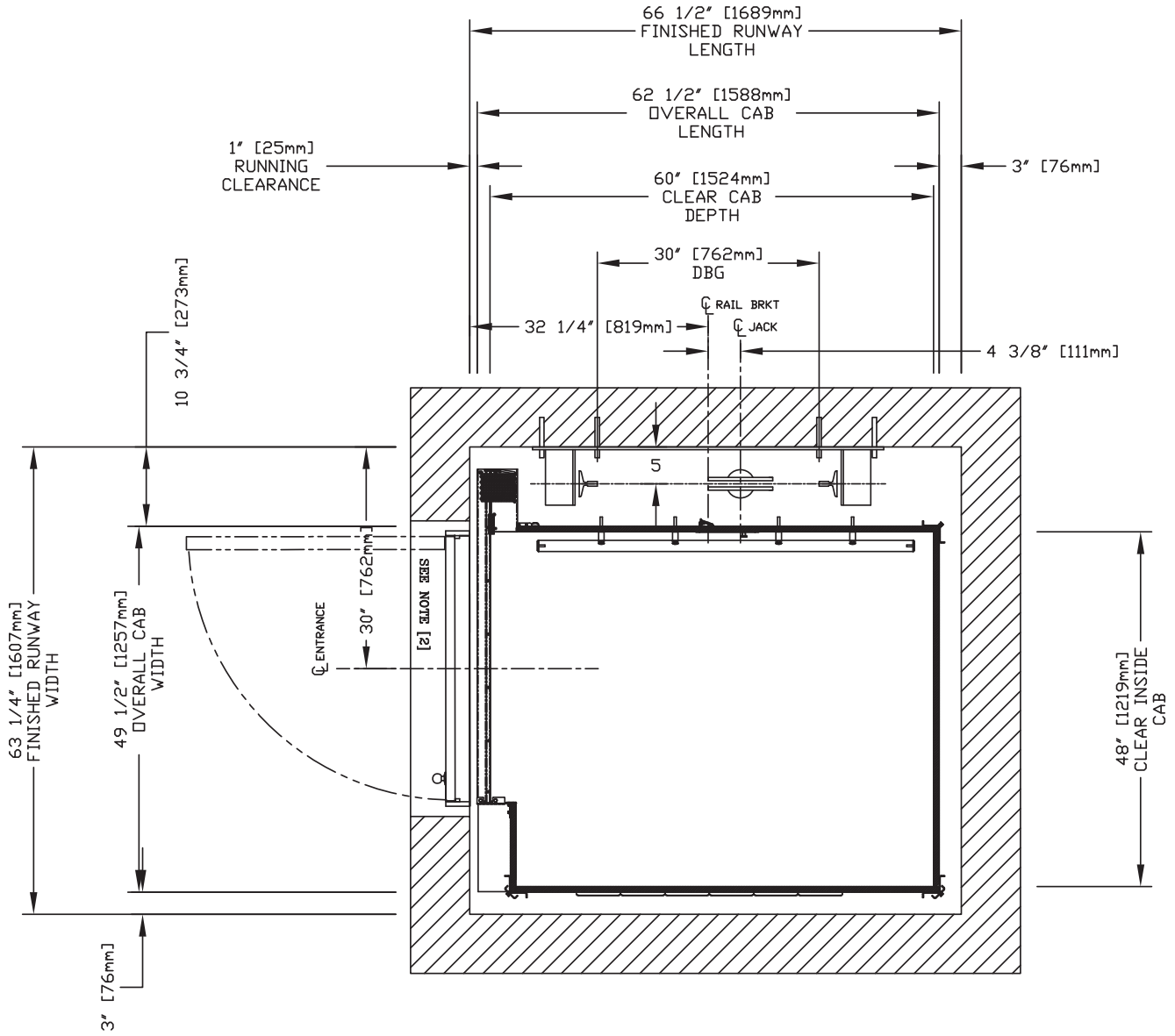

Plan view – Infinity HD 48" x 60" type 1 right-hand

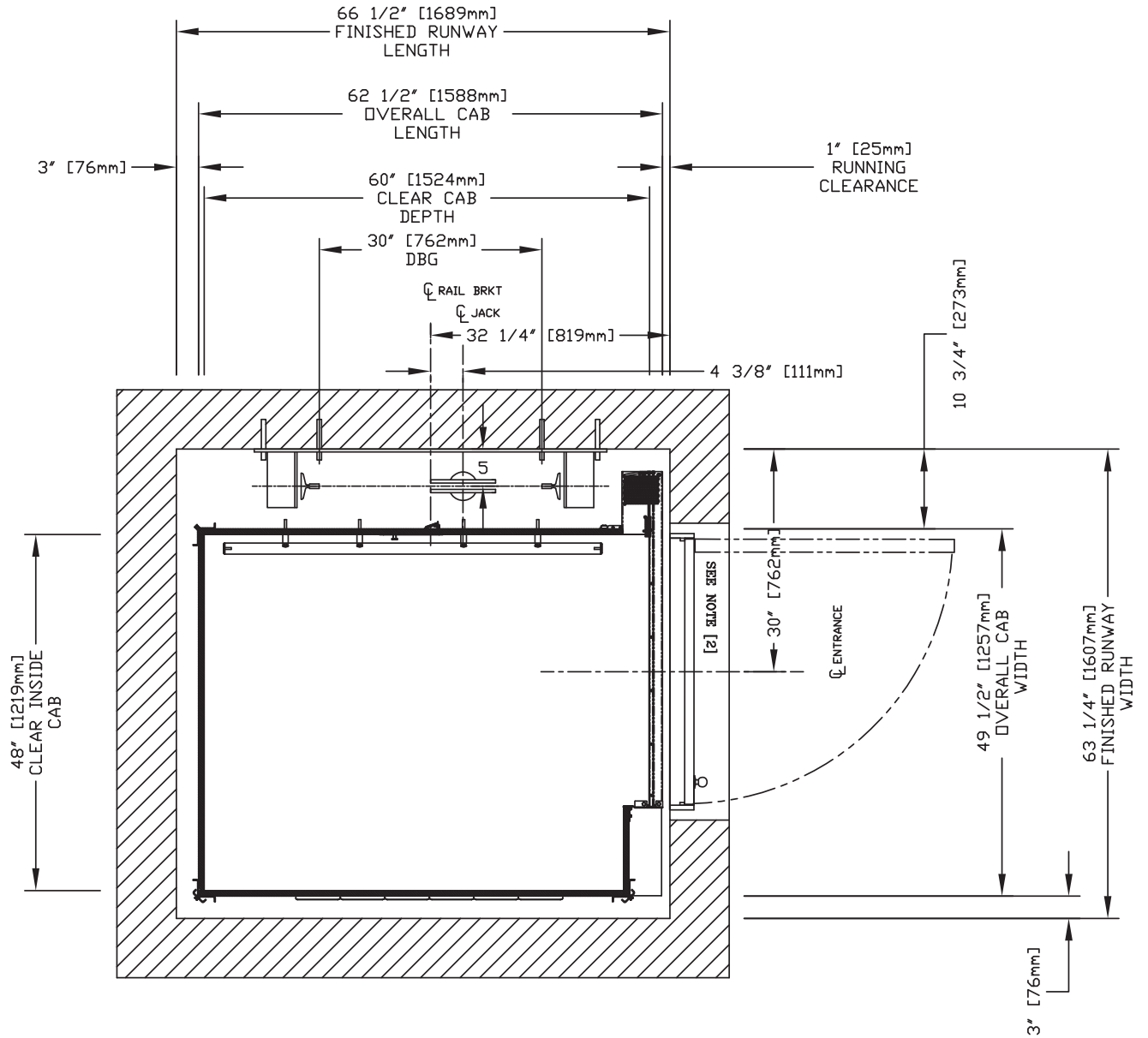

Plan view – Infinity HD 48" x 60" type 2

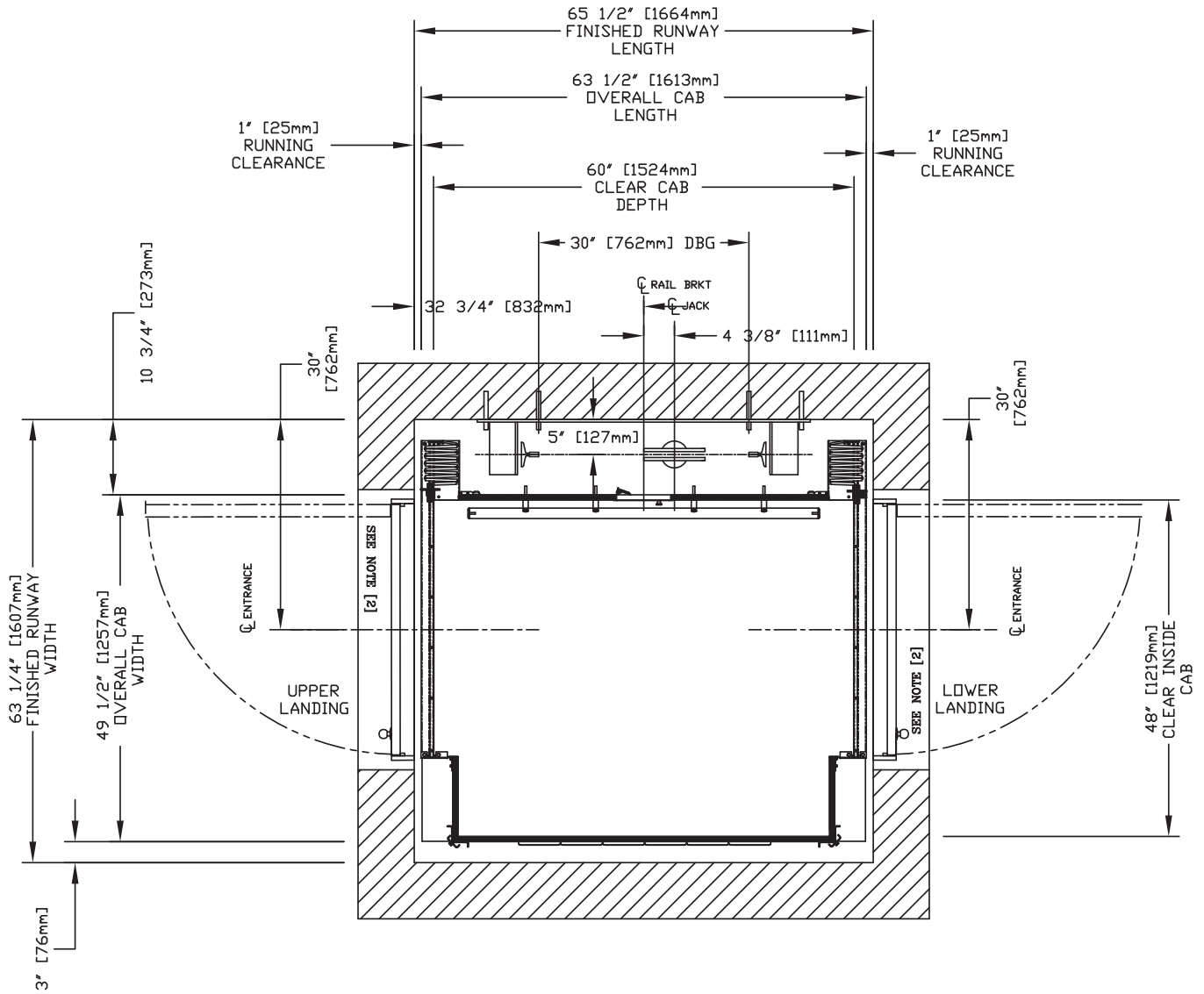

Plan view – Infinity HD 48" x 60" type 3

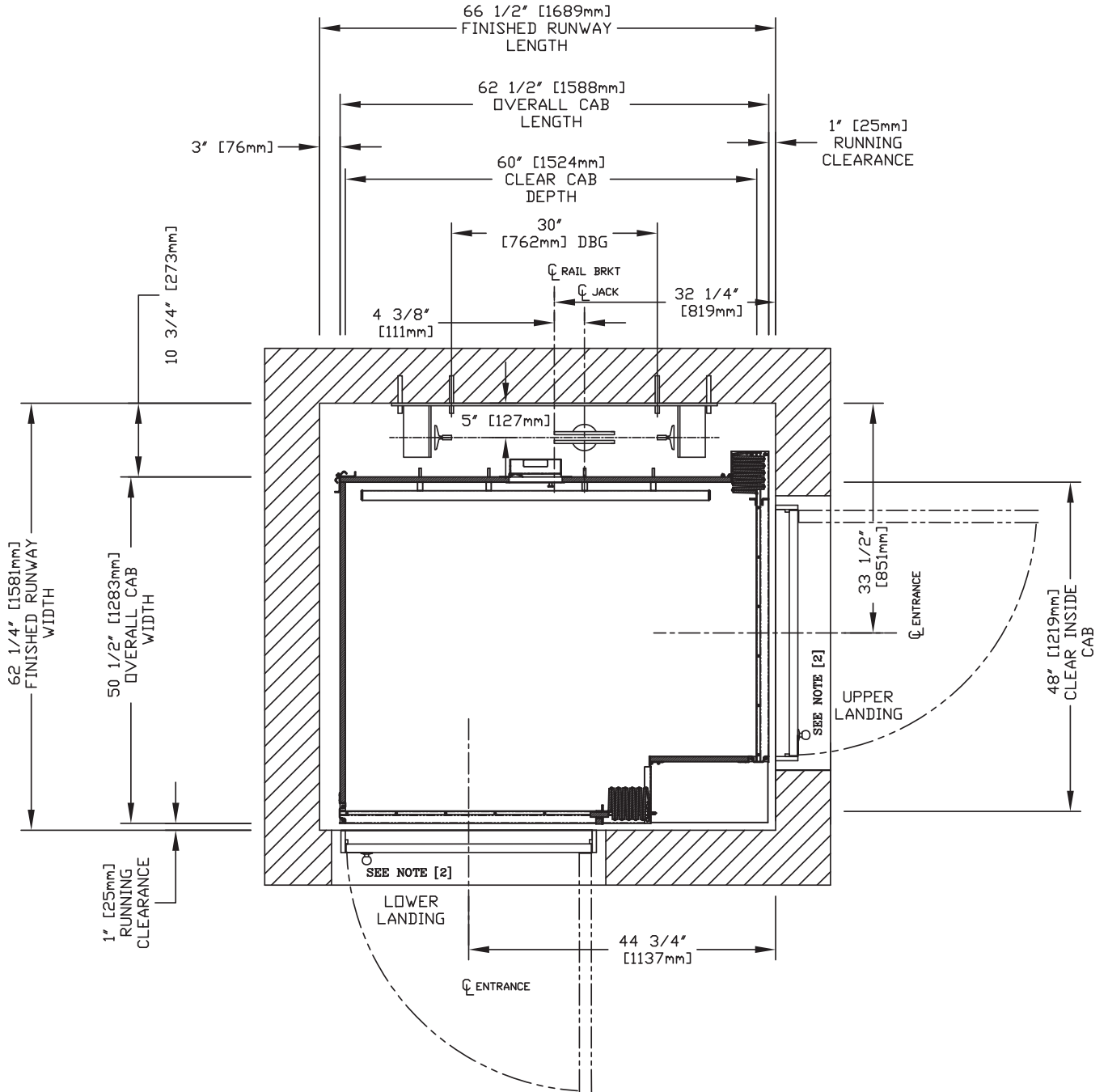

Plan view – Infinity HD 48" x 60" type 4

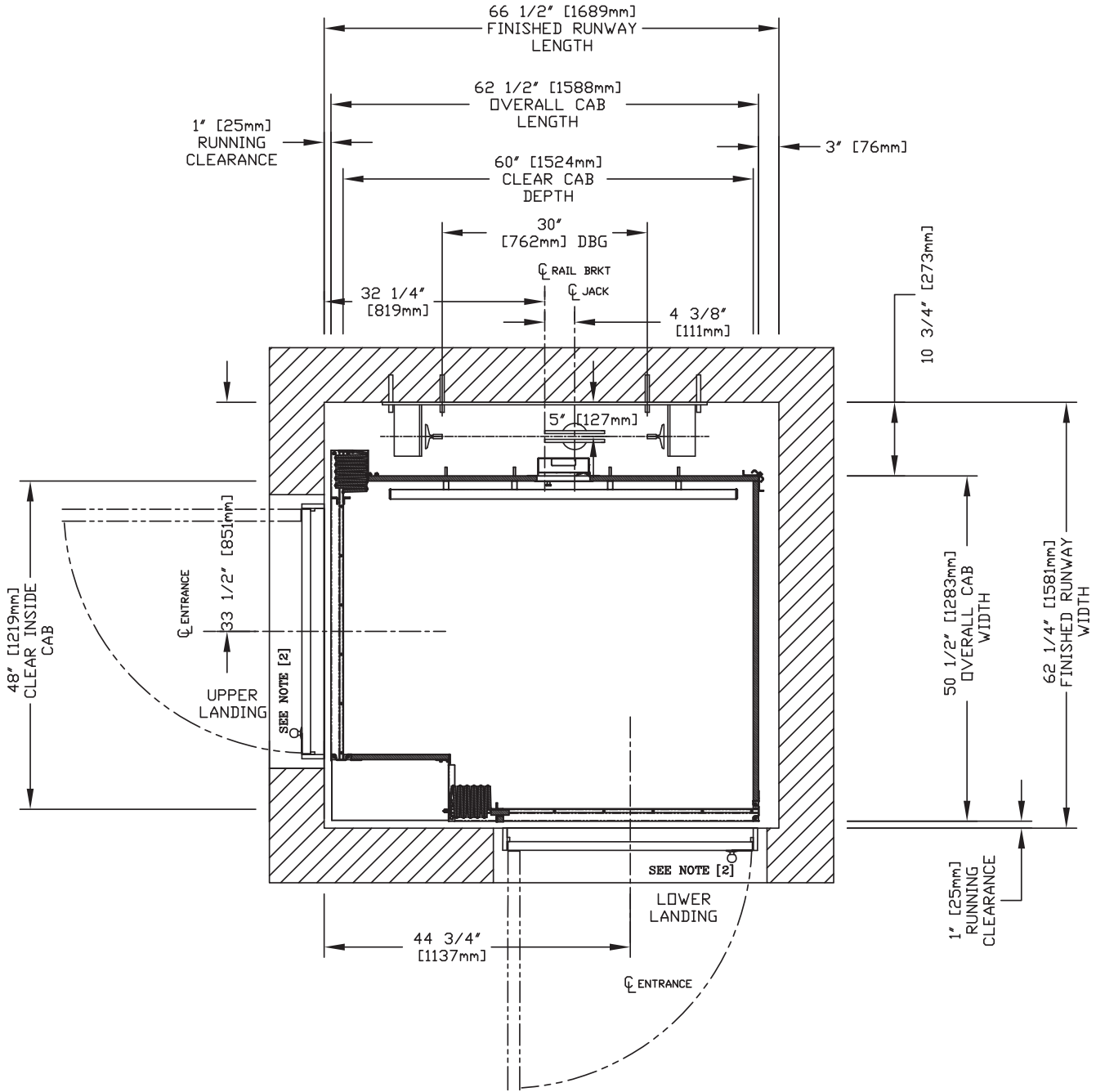

Plan view – Infinity HD 48" x 60" type 5 (left-hand gate stack/door swing)

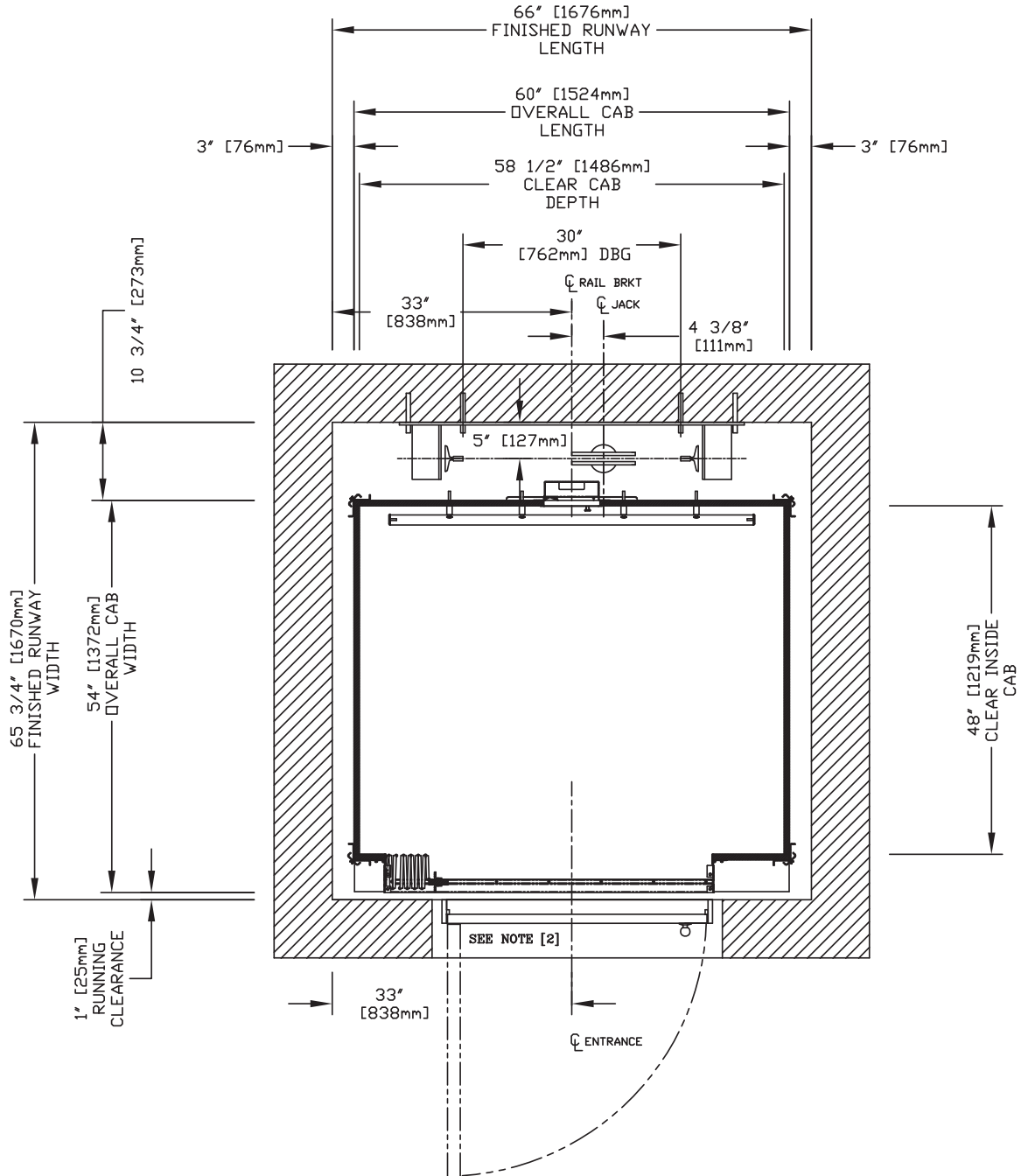

Plan view – Infinity HD 48" x 60" type 5 (right-hand gate stack/door swing)

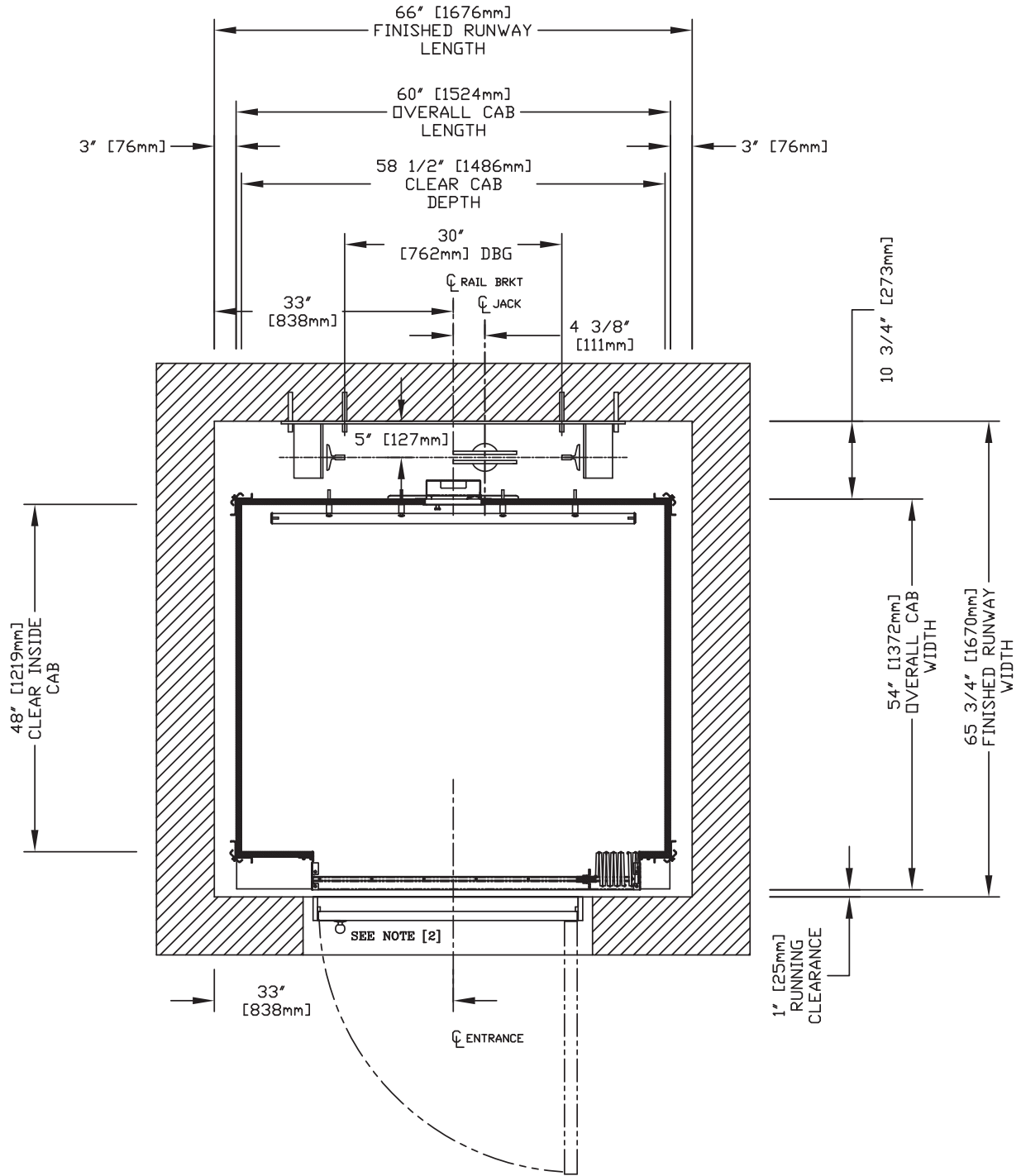

Door and gate specifications

For door and gate specifications, go to our website www.savaria.com, select the “architects and builders” tab at the top of the page and then select “Doors and Gates” from the menu on the left-hand side of the page.

The link is as follows: <http://www.savaria.com/architects/drawings/doors-gates/index.php>.

Recommendation: We recommend installation of a solid door as a hollow door may be too flexible and cause potential lock issues.

Loads on building and rail dimensions

RAIL FORCES		
*R1	*R2	CAPACITY
422 lbf.	251 lbf.	1400 lbs.
304 lbf.	194 lbf.	1000 lbs.
RAIL WEIGHT : 8.0 lbs / ft		

R3 NOTE:	
PIT FLOOR TO SUPPORT LOAD OF: * (INCLUDES IMPACT)	
CAPACITY	
8.22 Kips	1400 lbs.
5.6 Kips	1000 lbs.

FOR TOTAL PULL-OUT FORCE ON RAIL BRACKET, R1 MUST BE DOUBLED eg. 608 lbf for 1000 lbs.

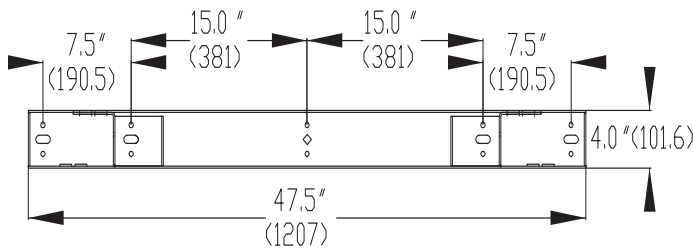
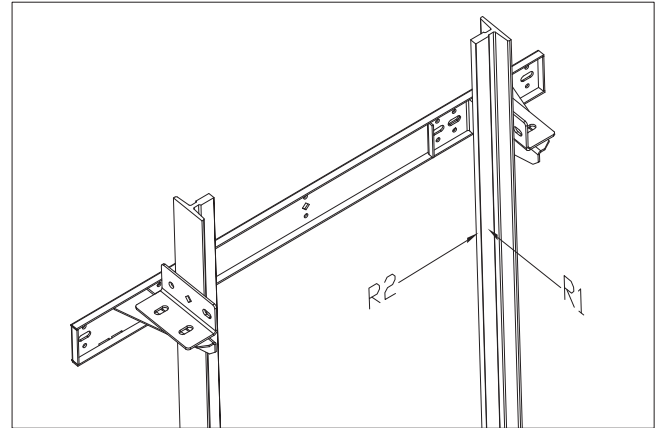
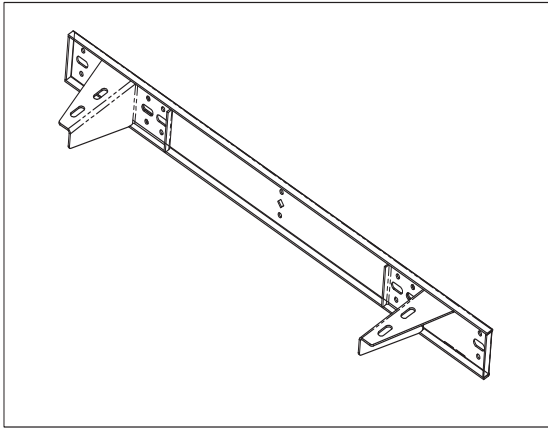

Rail bracket dimensions (Infinity)

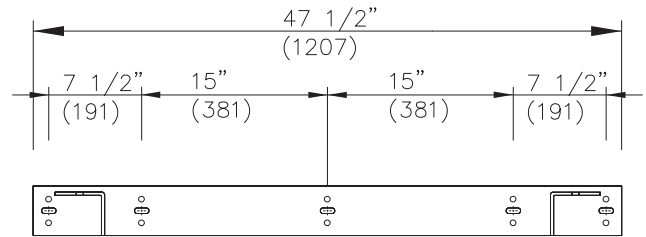

Rail bracket dimensions (Infinity HD)

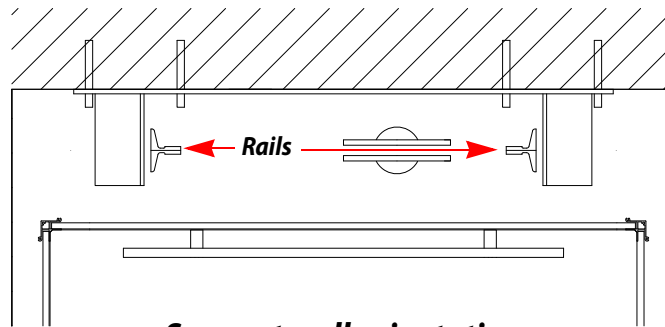

Support wall orientation

Pit details

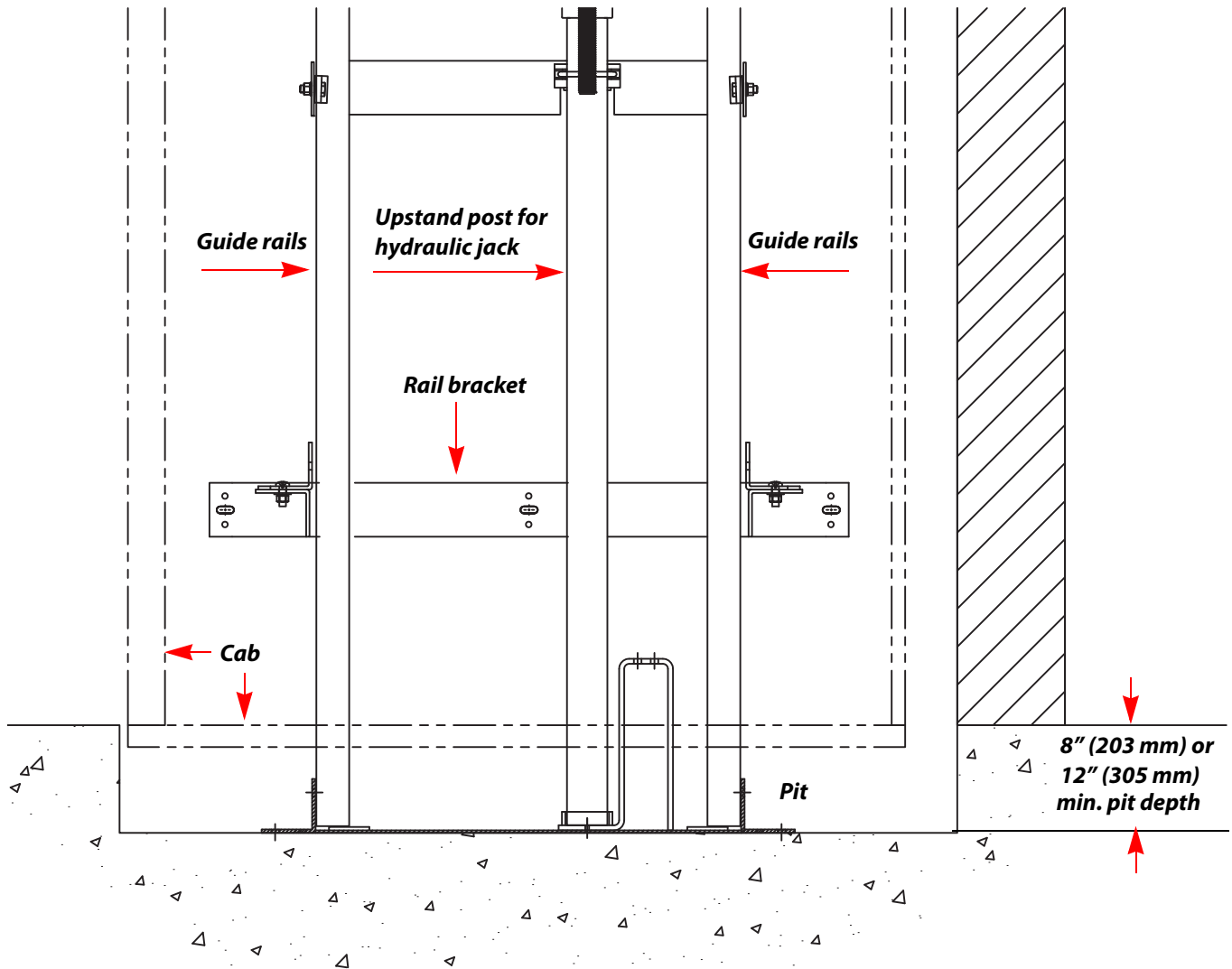

Hoistway and pit notes

- A load bearing wall is required to sustain rail reactions (refer to the section "Loads on building" on the previous page).
- Suggested hoistway pit floor construction consists of an 8" (203 mm) concrete slab poured on a natural or compacted soil with a minimum allowable bearing pressure of 1.0 KSF.
- The minimum compressive strength of the concrete at 28 days must be no less than 3000 PSI. #5 reinforcing steel (grade 60) must be placed at the bottom of the slab in two traverse directions and at a spacing of 12" (305 mm).
- Hoistway pit floor to support a load (including impact) of 5.6 kips (5600 lb/24.9 kN) for Infinity or 8.22 kips (8220 lb/36.6 kN) for Infinity HD.
- Minimum overhead clearance of 92" (2337 mm) for 80" (2032 mm) cab, 96" (2438 mm) for 84" cab, and 108" (2743 mm) for 96" cab.
- Minimum pit depth of 8" (203 mm) for Infinity and 12" (305 mm) for Infinity HD.
- Hoistway sizes reflect running and access clearances only. Consult your local AHJ to assure compliance with local codes.
- Hoistway is required to be free of all pipes, wiring and obstructions not related to the operation of the elevator.

Masonry construction – sectional view

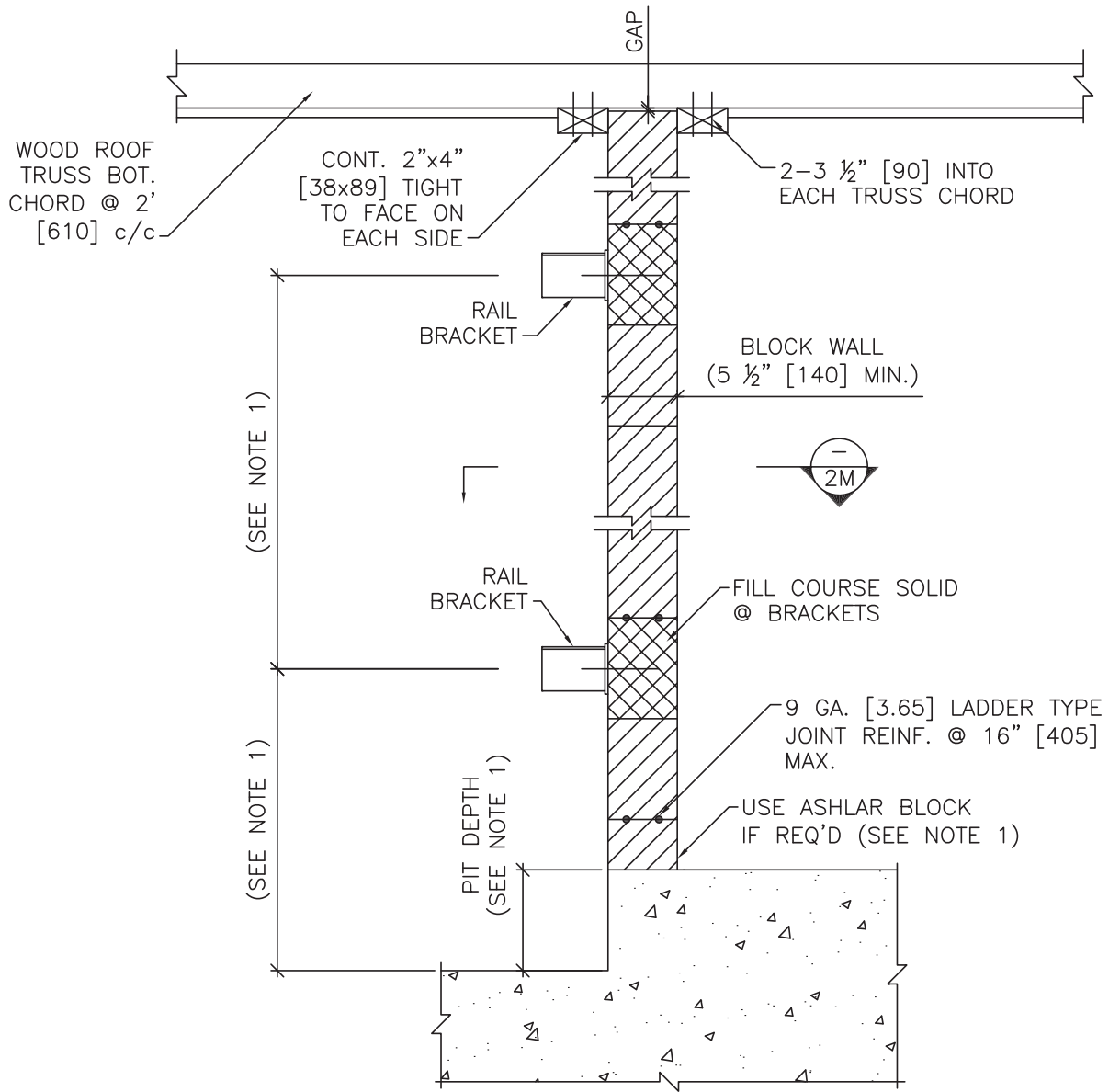

Masonry construction – plan view

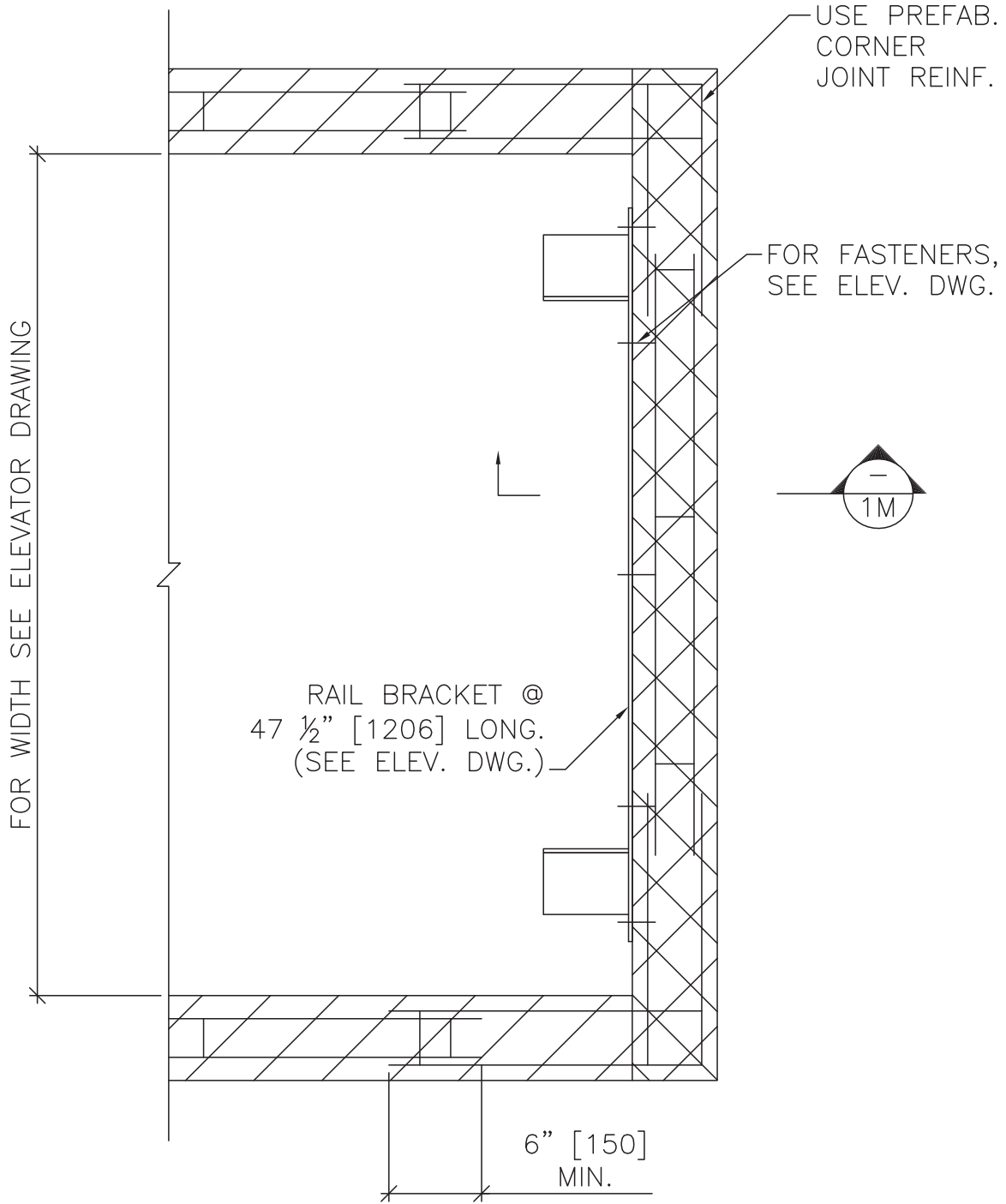

Wood construction – sectional view

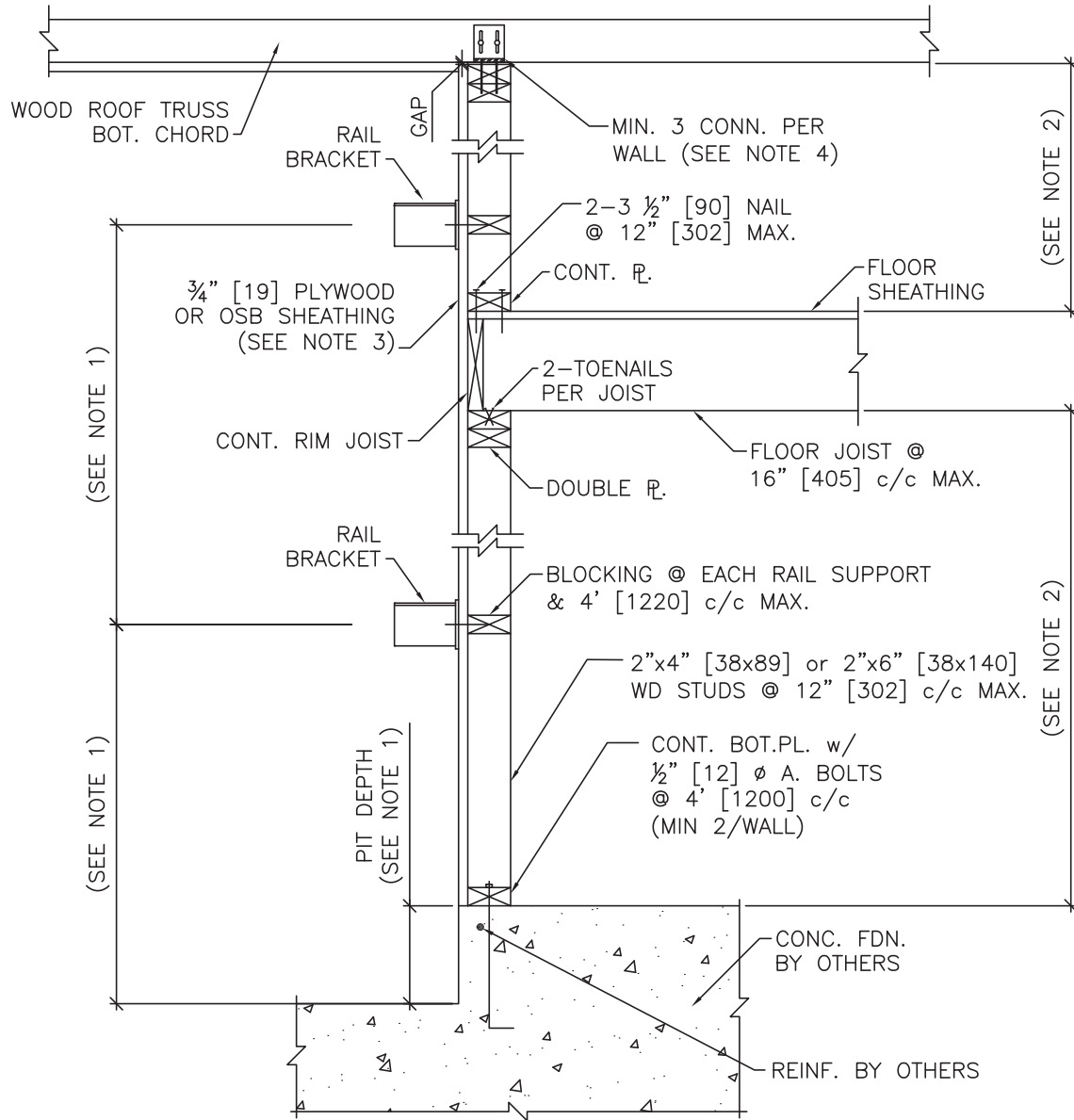

For Reference Only

Wood Stud Partitions (Load-Bearing) – 2-Hour Rating

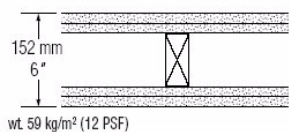

Wd Stud—2 layers 15.9 mm (5/8") SHEETROCK brand gypsum panels, FIRECODE core, or SHEETROCK brand gypsum panels, water-resistant, FIRECODE core, or SHEETROCK Vinyl-Faced Gypsum Panels, FIRECODE Core, ea side—2x4 400 mm (16") o.c.—base layer att with 48 mm (1 1/2") nails 150 mm (6") o.c.—face layer att with 60 mm (2 3/8") nails 200 mm (8") o.c.—joints fin—**ULC Des U301, UL Des U301**

N/A

SA924
SA928

101

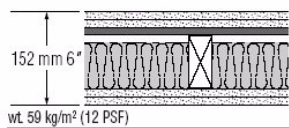

Wd Stud—2 layers 15.9 mm (5/8") SHEETROCK brand gypsum panels, FIRECODE C core, ea side—2x4 400 mm (16") o.c.—76 mm (3") THERMAFIBER SAFB—RC-1 chan or equiv one side, spaced 600 mm (24") o.c.—resil side screw att—opp side nail att—both base layers appl vert and face layers appl horiz—resil layers perim caulked—joints fin—**UL Des U334**

59

TL-67-239

SA924

102

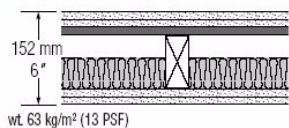

Wd Stud—2 layers 15.9 mm (5/8") SHEETROCK brand gypsum panels, FIRECODE C core, ea side—2x4 400 mm (16") o.c.—51 mm (2") THERMAFIBER SAFB—RC-1 chan or equiv one side, spaced 600 mm (24") o.c.—resil side screw att—opp side nail att—both base layers appl vert and face layers appl horiz—resil layers perim caulked—joints fin—**UL Des U334**

58

52

USG-810219

Based on same assembly (non-fire rated) without SAFB—**USG-810218**

SA924

103

Wood construction – plan view

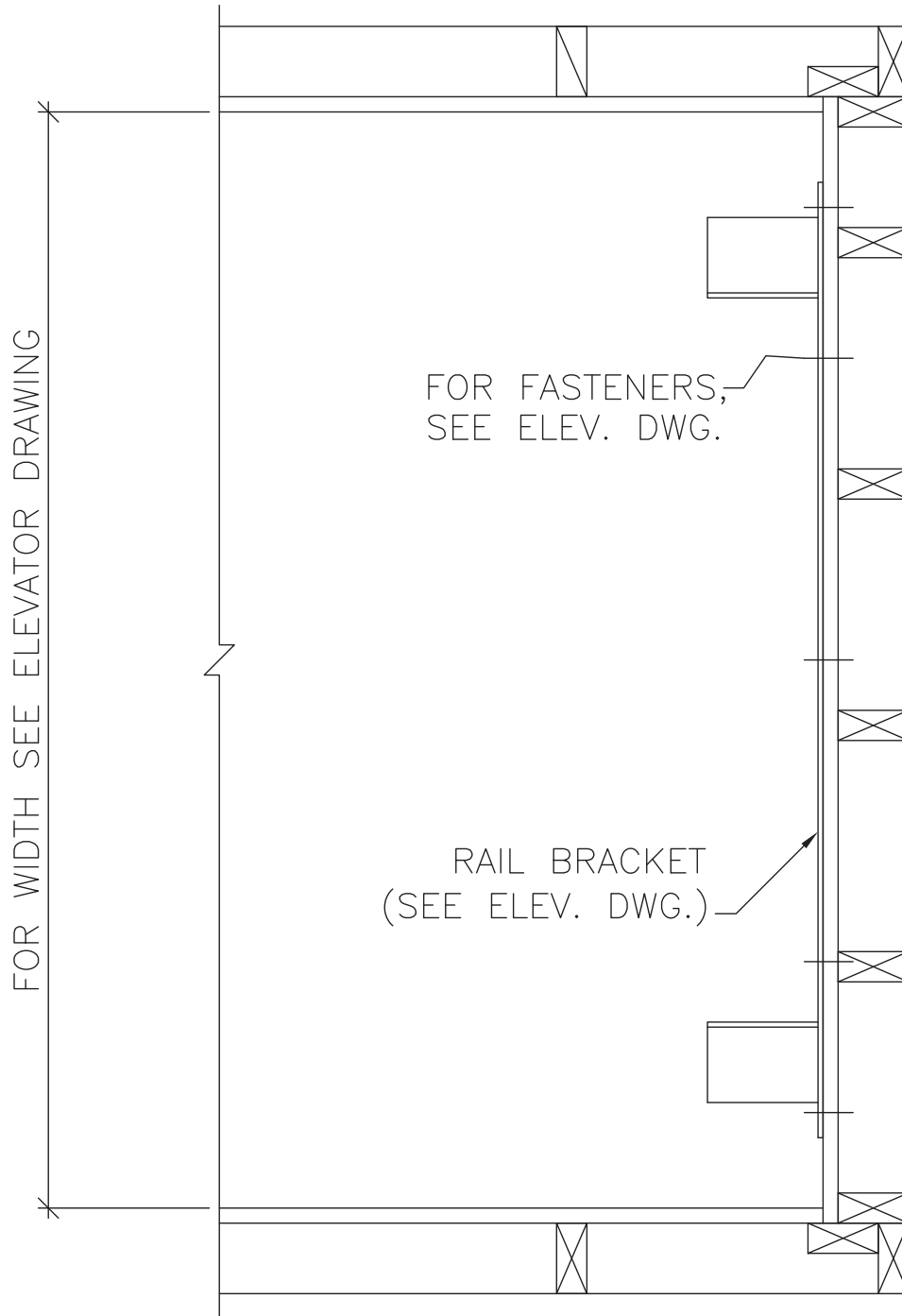

Suggested wall configuration for wood construction (sheet 1)

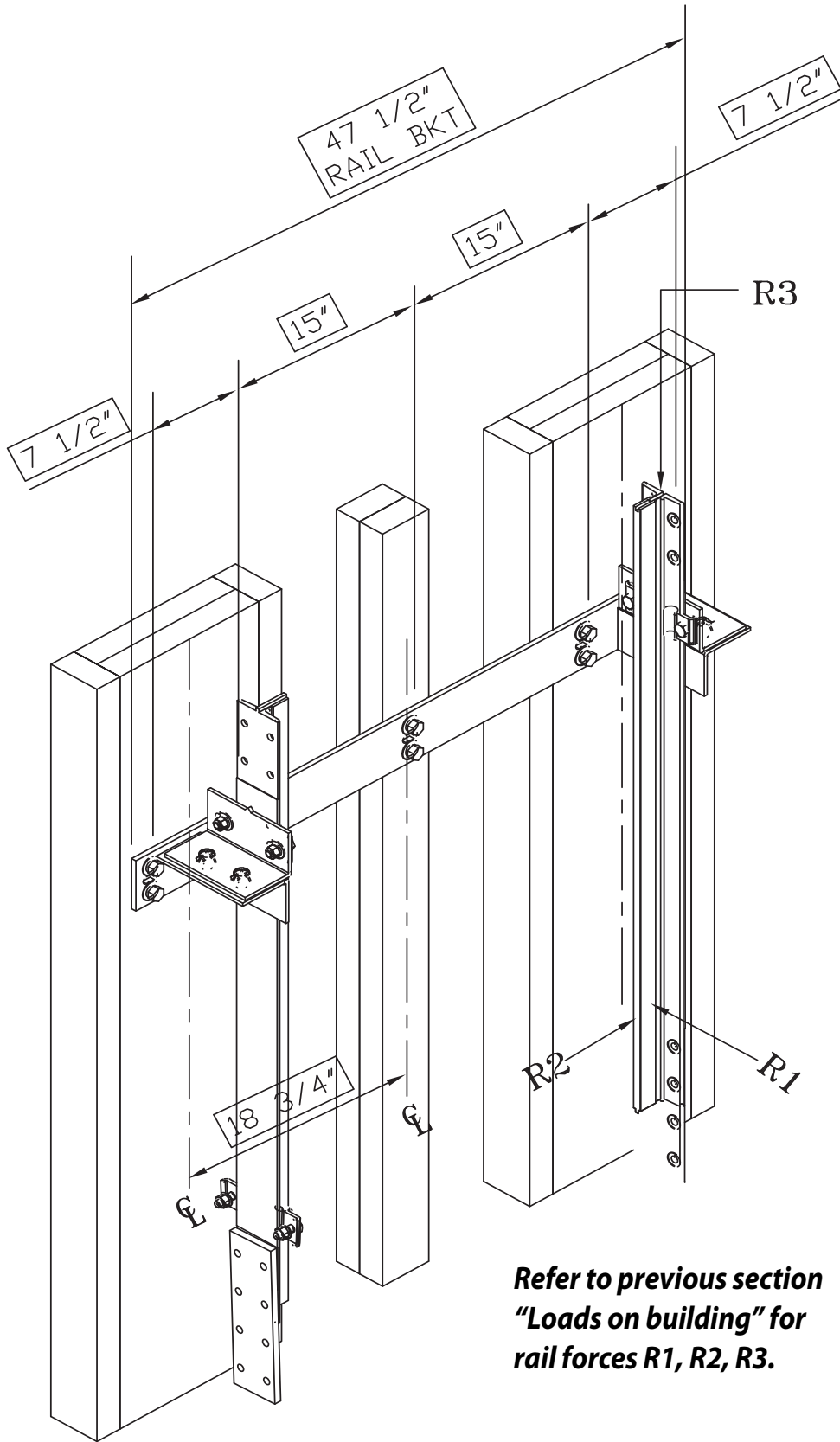

Suggested wall configuration for wood construction (sheet 2)

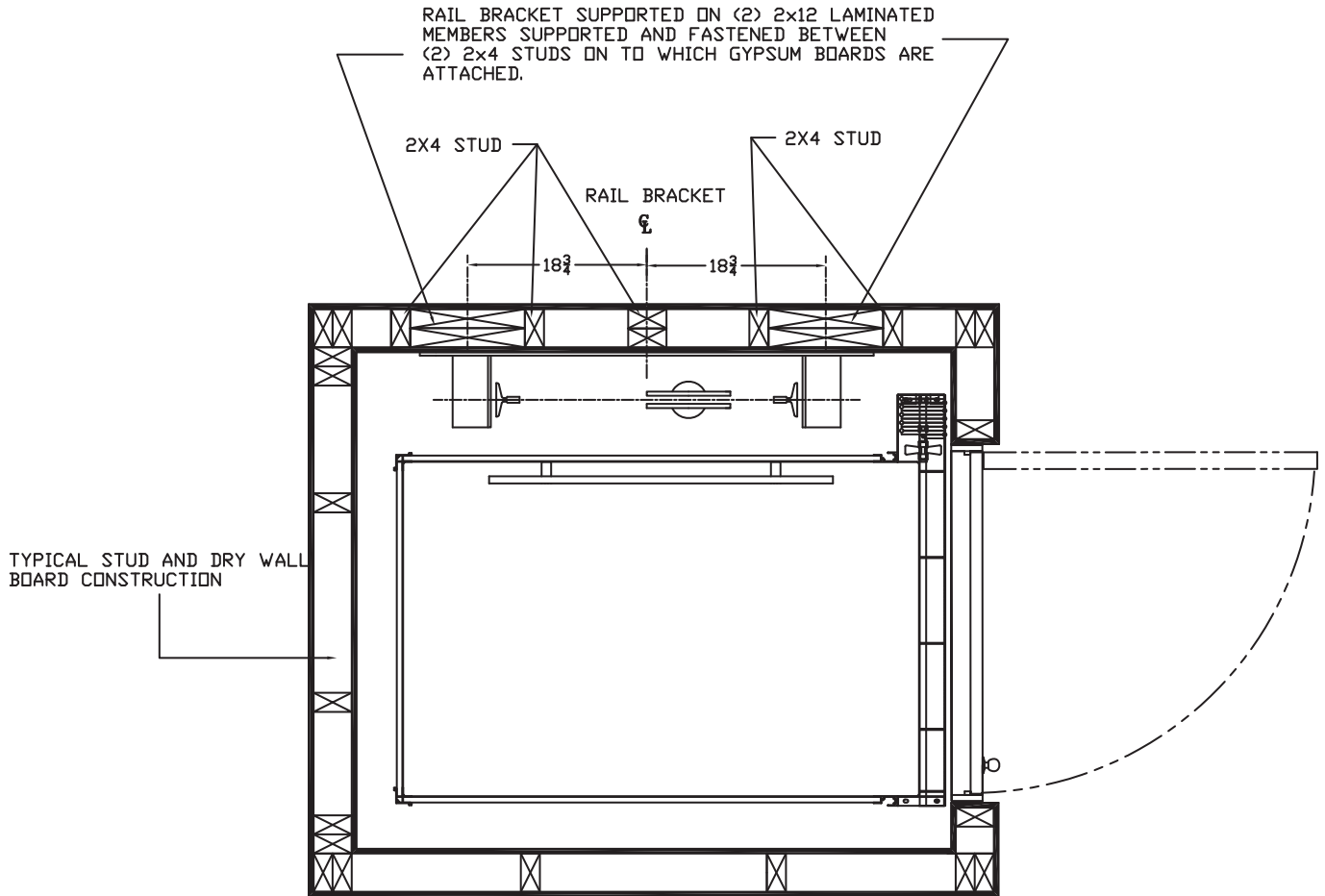

NOTE:

1. THIS DRAWING IS FOR REFERENCE ONLY. BUILDING STRUCTURAL ENGINEER TO ENSURE THAT THE BUILDING AND HOISTWAY WILL SAFELY SUPPORT ALL LOADS IMPOSED BY THE LIFT EQUIPMENT
2. FIRE RATING OF HOISTWAY IS SUBJECT TO LOCAL BUILDING CODES.

Rail support wall specifications

Drawing notes

- 1) See the lift installation (shop) drawings for rail bracket spacing and pit depth.
- 2) Wall lateral support spacing:
 - For 2" x 4" studs, use 6 ft 10" (2090 mm) max.
 - For 2" x 6" studs, use 13 ft 6" (4120 mm) max.
- 3) Sheathing installation: install sheets vertically full width of shaft or min. centred on rail brackets.
- 4) Connectors to resist horizontal load but allow vertical movement. For wood, use 2" x 1/4" cap screw lag bolts.

General specifications

- G1 The design and construction of all work is to conform to the local applicable building code.
- G2 Read the installation (shop) drawings in conjunction with all related architectural, mechanical, electrical, and lift drawings as well as any other contract documents.
- G3 The wall drawings have been prepared using engineering principles and the design loads that are applied by the lift rails to the wall. However, the details and member sizes and the attachments to the structure should not be construed as a complete design of the wall system. The contractor and/or the project engineer is responsible to evaluate the other loads that are applied to the wall from the floor or roof system and modify member sizes or connections as required by their analysis.
- G4 Do not scale the drawings.
- G5 See the lift installation (shop) drawings for service loads (including dynamic effects) which are:
 - Horizontal load parallel to the wall: 194 lbf (0.86 kN) for Infinity; 251 lbf (1.12 kN) for Infinity HD
 - Horizontal load perpendicular to the wall: 304 lbf (1.35 kN) for Infinity; 422 lbf (1.88 kN) for Infinity HD
- G6 Wood: SPF NO 1/2 Mix
Concrete: 3000 psi (20 Mpa) @ 28 days. If exposed use 5% to 7% air content.
Anchor bolts: ASTM A307
Mortar: Type "S"
Masonry grout: 2100 psi (14 Mpa) high slump
Masonry block: 2100 psi (14 Mpa) on net area
- G7 Wall to be installed plumb and square within 1/8" (3 mm) of top and bottom of shaft.
- G8 Wall lateral support spacing (H) selected for maximum horizontal deflection of H/360 from rail loads.

Wood construction

- W1 Separate wood from concrete with waterproof barrier or use pressure treated wood.
- W2 Bridging maximum spacing: Load bearing or shear walls – 4 ft (1219 mm) c/c.
- W3 Nail or screw sheathing at 6" (152 mm) c/c at edges and 12" c/c to other members.
Use 2.5" standard Ardox nails or 2" #12 screws.

Masonry construction

- M1 All masonry construction to conform to applicable local standards
- M2 Reinforce lintel blocks with 2 m-15 m bottom bars unless noted.
- M3 Provide continuous ladder type joint reinforcement at 16" (400 mm) c/c.

Provisions by others

Hoistway

- The hoistway must be designed and built in accordance with all applicable codes (identified on the cover of this manual) and all state and local codes.
- Due to close running clearances, owner/agent must ensure that hoistway and pit (where provided) are level, plumb and square and are in accordance with the dimensions on the installation (shop) drawings.

Minimum overhead clearance

- Owner/agent must ensure minimum overhead clearance is in compliance with codes.

Construction site

- Owner/agent to provide all masonry, carpentry and drywall work as required and shall patch and make good (including finish painting) all areas where walls/floors may need to be cut, drilled or altered in any way to permit the proper installation of the lift.

Dimensions

- Contractor/customer to verify all dimensions and report any discrepancies to our office immediately.

Structural

- Structural engineer to assure that building and shaft will safely support all loads imposed by the lift equipment. Refer to the tables on installation (shop) drawings for loads imposed by the equipment.
- Suitable lintels must be provided by owner/agent. Door frames are not designed to support overload wall loads.

Entrances

- Entrance assemblies must be adjusted to align with platform and interlock equipment. Others to allow an adequate rough opening.
- Return walls at entrances must be built-in by others after entrance assemblies are in place. Entrance assembly must be securely fastened to walls by elevator contractor.
- Fascia panel below upper level entrance where required. Fascia panel must be fastened to a solid wall and be perpendicular to the floor and walls. Hoistway fascia is not self-supporting for long, continuous runs void of entrances. Adequate support for the fascia must be provided.

Machine room

- Machine room must be located at the lowest level adjacent to hoistway, unless shown otherwise on installation (shop) drawings. Field adjustment by installer may be necessary to meet job site conditions or regulations. Access to machine room to be through self-closing lockable door.
- Sleeves for oil and electric lines must be provided from machine room to runway as required (positioned per installer's instructions).

Electrical

- Power supply with a lockable fused disconnect and auxiliary contact to break the battery feed, or circuit breakers with a 3-pole breaker for battery feed required, in compliance with electrical code, located on the wall on the lock jamb side of the machine room door. Contact your Savaria dealer or refer to one of the tables on the next page for OEM part numbers.
- Permanent power of 208 volts, three-phase, 30 amps or 230 volts, single-phase, 40 amps must be supplied by others before installation begins.
- Owner/agent to ensure at least 9.3 foot-candles (100 lux) ambient lighting over lift area.
- Remote hall call (when supplied) to be installed by the owner/agent at 42" (1067 mm) from landing floor and 8" (203 mm) from the door edge.

For Infinity (3 HP pump unit)

Disconnect Switch Types & Accessories	Cutler Hammer	Federal Pioneer	Siemens
1 Phase 3 H.P. Pump Unit			
2 Pole 240V 1 PH	1HD221N	1322SN	ID321
Required Auxiliary Contact	DS16CP	E1K-1AEV-W94	MSSAK 116
Required Type "D" Fuse (Buss type "FRN" or equal)	2@30 amp	2@30 amp	2@30 amp
3 Phase 3 H.P. Pump Unit			
3 Pole 208V 3 PH	1HD321N	1332SN	ID321
Required Auxiliary Contact	DS16CP	E1K-1AEV-W94	MSSAK 116
Required Type "D" Fuse (Buss type "FRN" or equal)	3@20 amp	3@20 amp	3@20 amp
Cab Lighting			
1 Pole Solid Neutral 120V 1 PH	GP 111N	86211	CFN 211
Required Type "D" Fuse (Buss type "T" or equal)	1@15 amp	1@15 amp	1@15 amp

For Infinity HD (5 HP pump unit)

Disconnect Switch Types & Accessories	Cutler Hammer	Federal Pioneer	Siemens
1 Phase 5 H.P. Pump Unit			
2 Pole 240V 1 PH	1HD221N	1322SN	ID321
Required Auxiliary Contact	DS16CP	E1K-1AEV-W94	MSSAK 116
Required Type "D" Fuse (Buss type "FRN" or equal)	2@40 amp	2@40 amp	2@40 amp
3 Phase 5 H.P. Pump Unit			
3 Pole 208V 3 PH	1HD321N	1332SN	ID321
Required Auxiliary Contact	DS16CP	E1K-1AEV-W94	MSSAK 116
Required Type "D" Fuse (Buss type "FRN" or equal)	3@30 amp	3@30 amp	3@30 amp
Cab Lighting			
1 Pole Solid Neutral 120V 1 PH	GP 111N	86211	CFN 211
Required Type "D" Fuse (Buss type "T" or equal)	1@15 amp	1@15 amp	1@15 amp

COP dimensions

<p>C2P-1__STD</p>	<p>C2P-12__STD</p>	<p>C2P-123__STD</p>	<p>C2P-1234__STD</p>	<p>C2P-12345__STD</p>	<p>C2P-123456__STD</p>
<p>C2P-1__CST</p>	<p>C2P-12__CST</p>	<p>C2P-123__CST</p>	<p>C2P-1234__CST</p>	<p>C2P-12345__CST</p>	<p>C2P-123456__CST</p>

Hall call dimensions

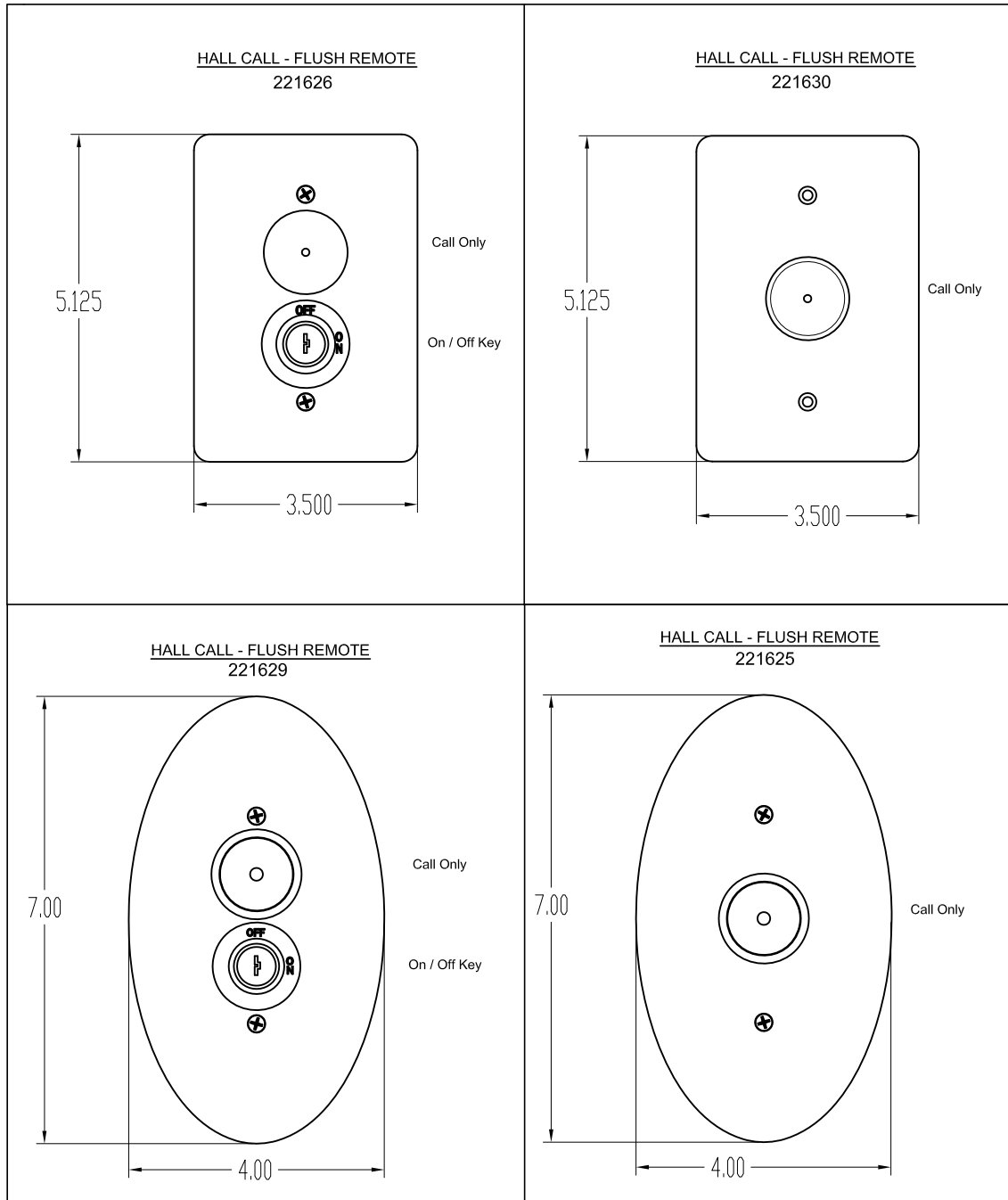

Appendix A

Infinity with Auto Slim Doors

This appendix provides elevation and plan view drawings for the various Infinity cab types with Auto Slim Doors.

Drawings for the auto slim doors entrance assembly are provided on the next two pages.

Elevation view – Infinity type 1L with auto slim doors

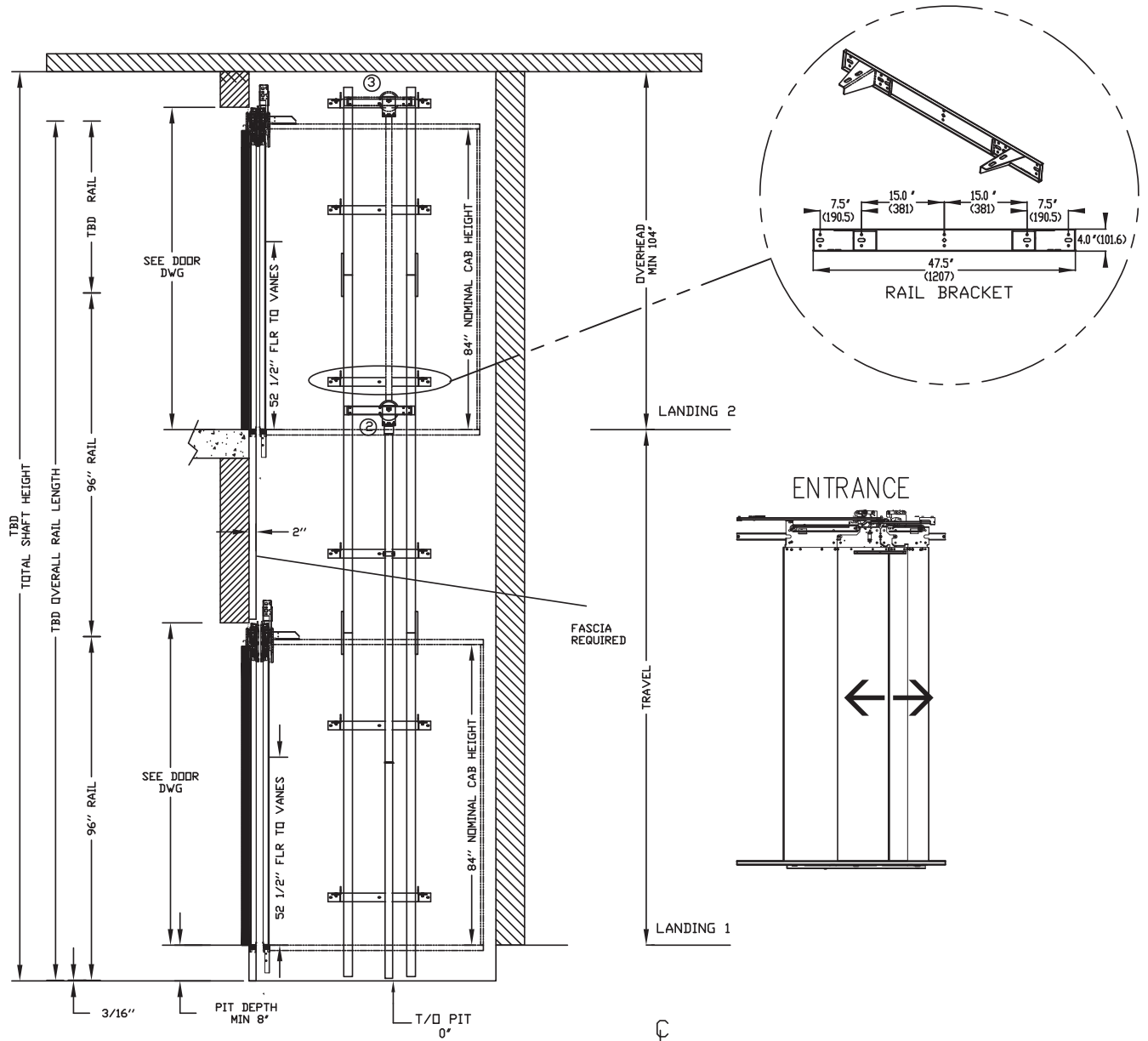

RAIL FORCES	
*R1	*R2
304lbf.	194lbf.
RAIL WEIGHT : 8.0 lbs / Ft	

R3 NOTE:
 PIT FLOOR TO SUPPORT LOAD OF:
 5.6kips * (INCLUDES IMPACT)
 FOR TOTAL PULL-OUT FORCE ON RAIL BRACKET,
 R1 MUST BE DOUBLED eg.

RAIL BRACKET

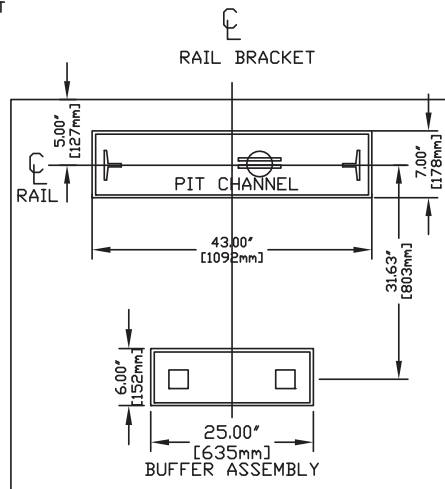

Plan view – Infinity type 1L with auto slim doors

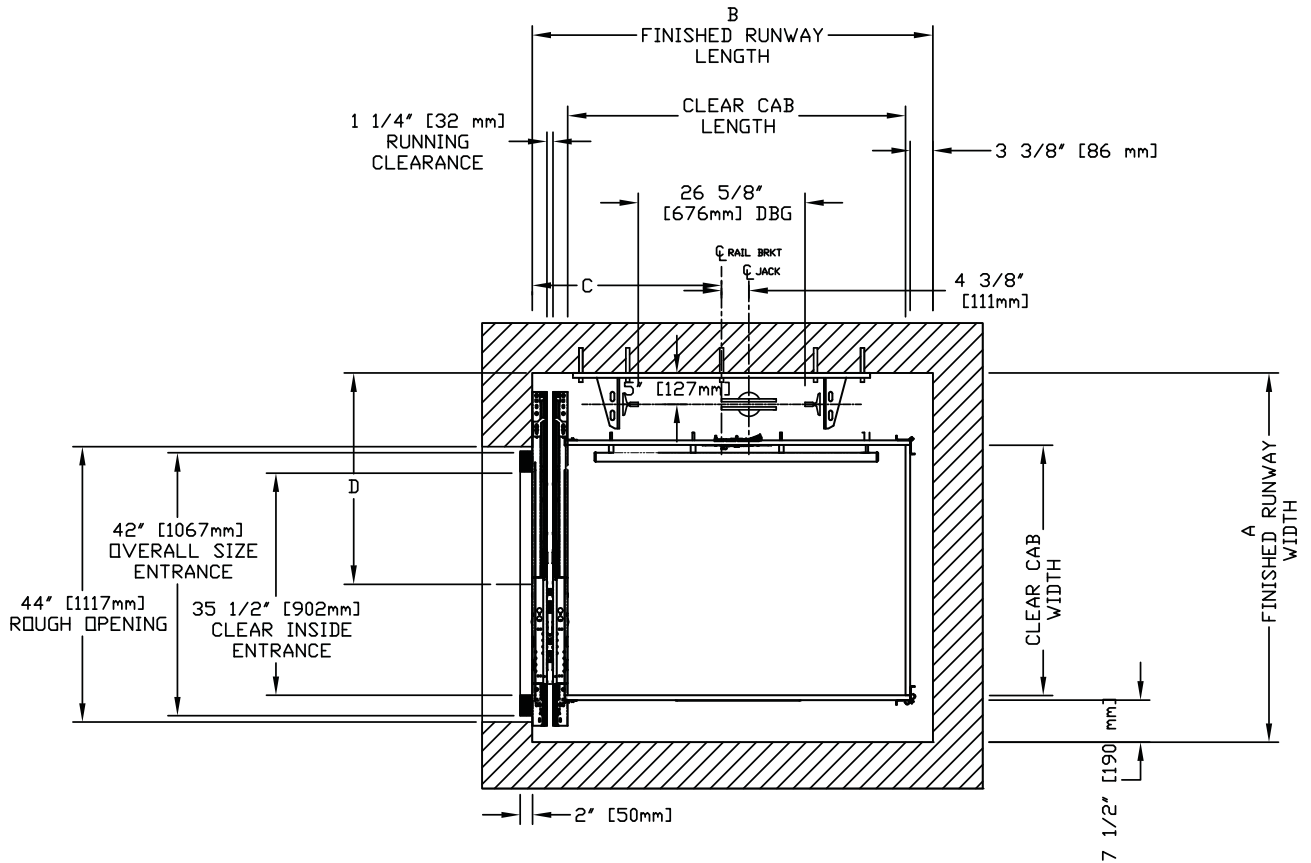

CLEAR INSIDE CAB WIDTH		CLEAR INSIDE CAB LENGTH		A FINISHED RUNWAY WIDTH		B FINISHED RUNWAY LENGTH		C RAIL CENTER LINE		D DOOR CENTER LINE	
mm	Inches	mm	Inches	mm	Inches	mm	Inches	mm	Inches	mm	Inches
914	36	1219	48	1499	59	1473	58	775	30.5	838	33.00
914	36	1372	54	1499	59	1626	64	826	32.5	838	33.00
914	36	1524	60	1499	59	1778	70	902	35.5	838	33.00
1016	40	1372	54	1524	60	1626	64	826	32.5	883	34 3/4
HD 1219	48	1524	60	1626	64	1778	70	914	36.0	857	33 3/4

Elevation view – Infinity type 1R with auto slim doors

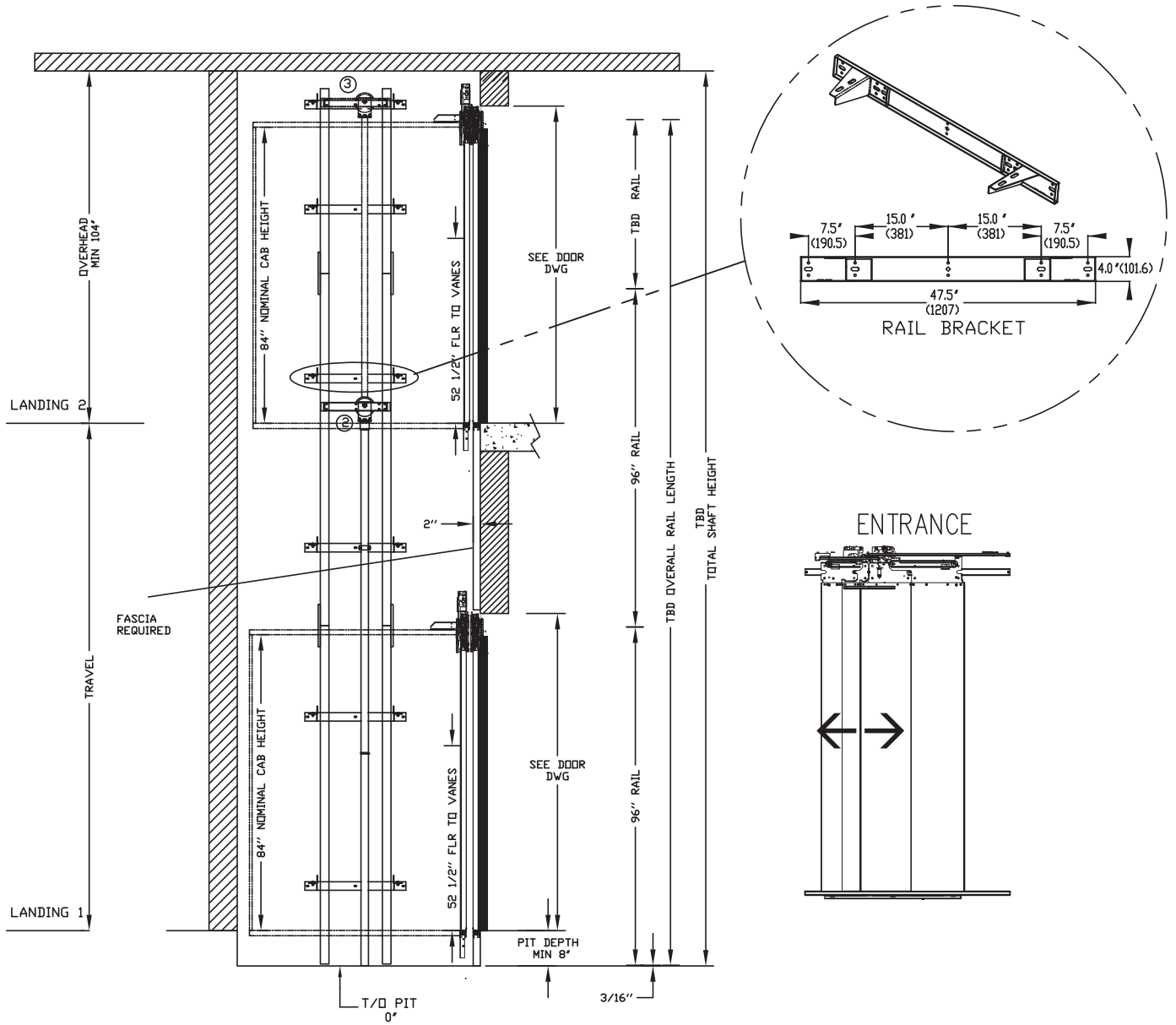

RAIL FORCES		R3 NOTE:
		PIT FLOOR TO SUPPORT LOAD OF: 5.6klps * (INCLUDES IMPACT)
*R1	*R2	FOR TOTAL PULL-OUT FORCE ON RAIL BRACKET, R1 MUST BE DOUBLED eg.
304lbf.	194lbf.	
RAIL WEIGHT : 8.0 lbs / ft		

RAIL BRACKET

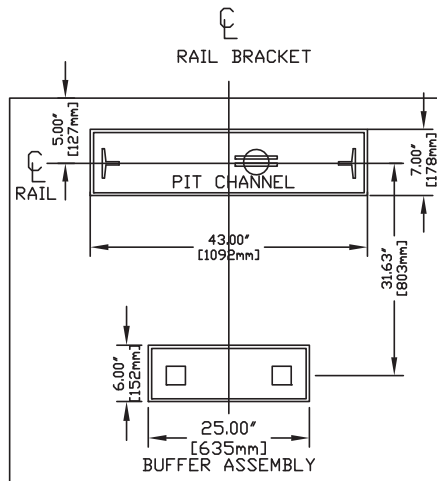

Plan view – Infinity type 1R with auto slim doors

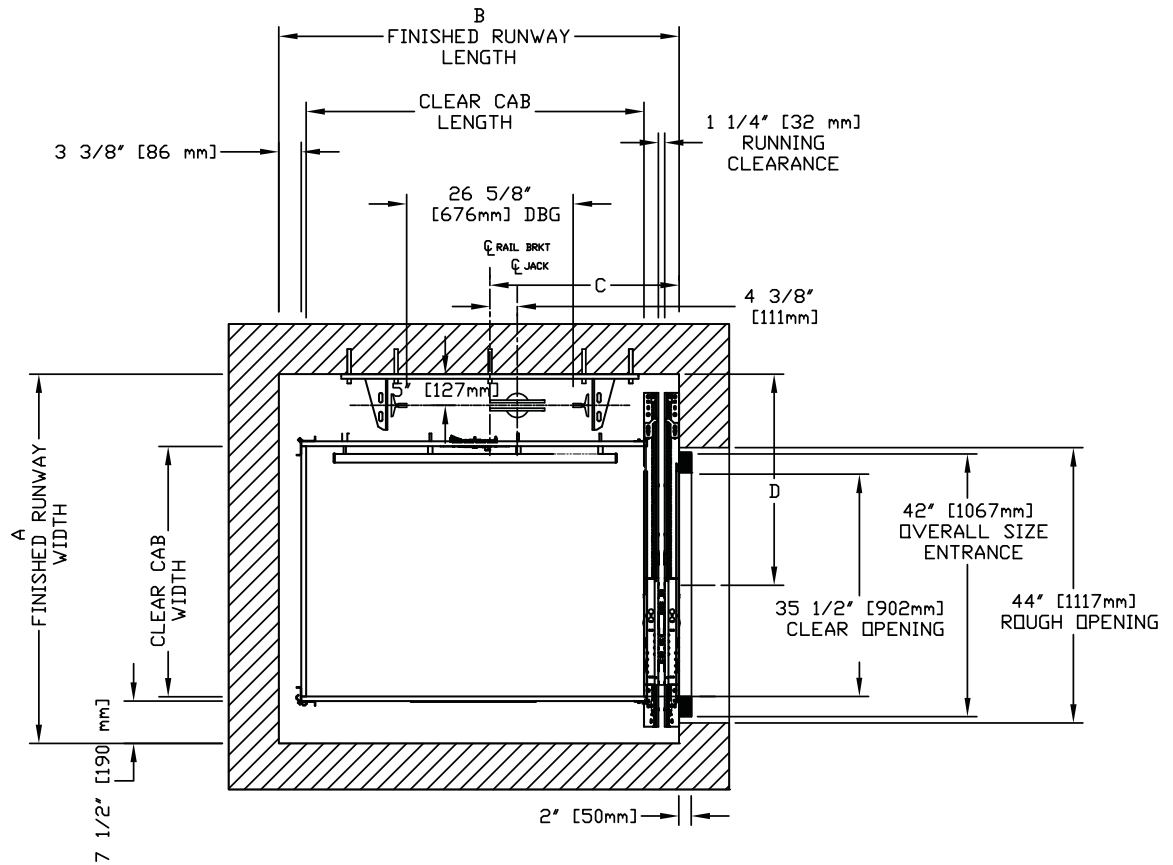

CLEAR INSIDE CAB WIDTH		CLEAR INSIDE CAB LENGTH		A FINISHED RUNWAY WIDTH		B FINISHED RUNWAY LENGTH		C RAIL CENTER LINE		D DOOR CENTER LINE	
mm	Inches	mm	Inches	mm	Inches	mm	Inches	mm	Inches	mm	Inches
914	36	1219	48	1499	59	1473	58	775	30.5	838	33.0
914	36	1372	54	1499	59	1626	64	826	32.5	838	33.0
914	36	1524	60	1499	59	1778	70	902	35.5	838	33.0
1016	40	1372	54	1524	60	1626	64	826	32.5	883	34 3/4
1219	48	1524	60	1626	64	1778	70	914	36.0	857	33 3/4

HD

Elevation view – Infinity type 2 with auto slim doors

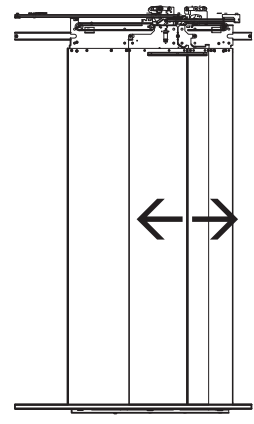
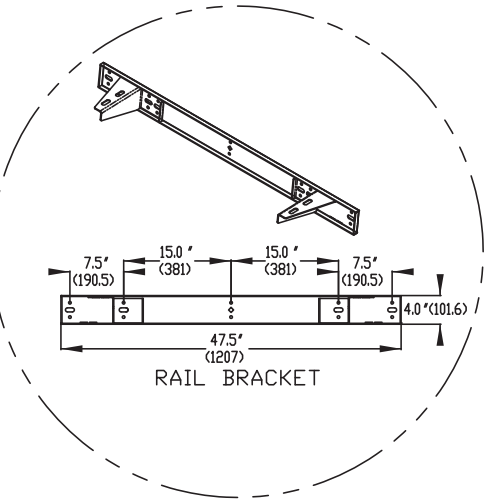
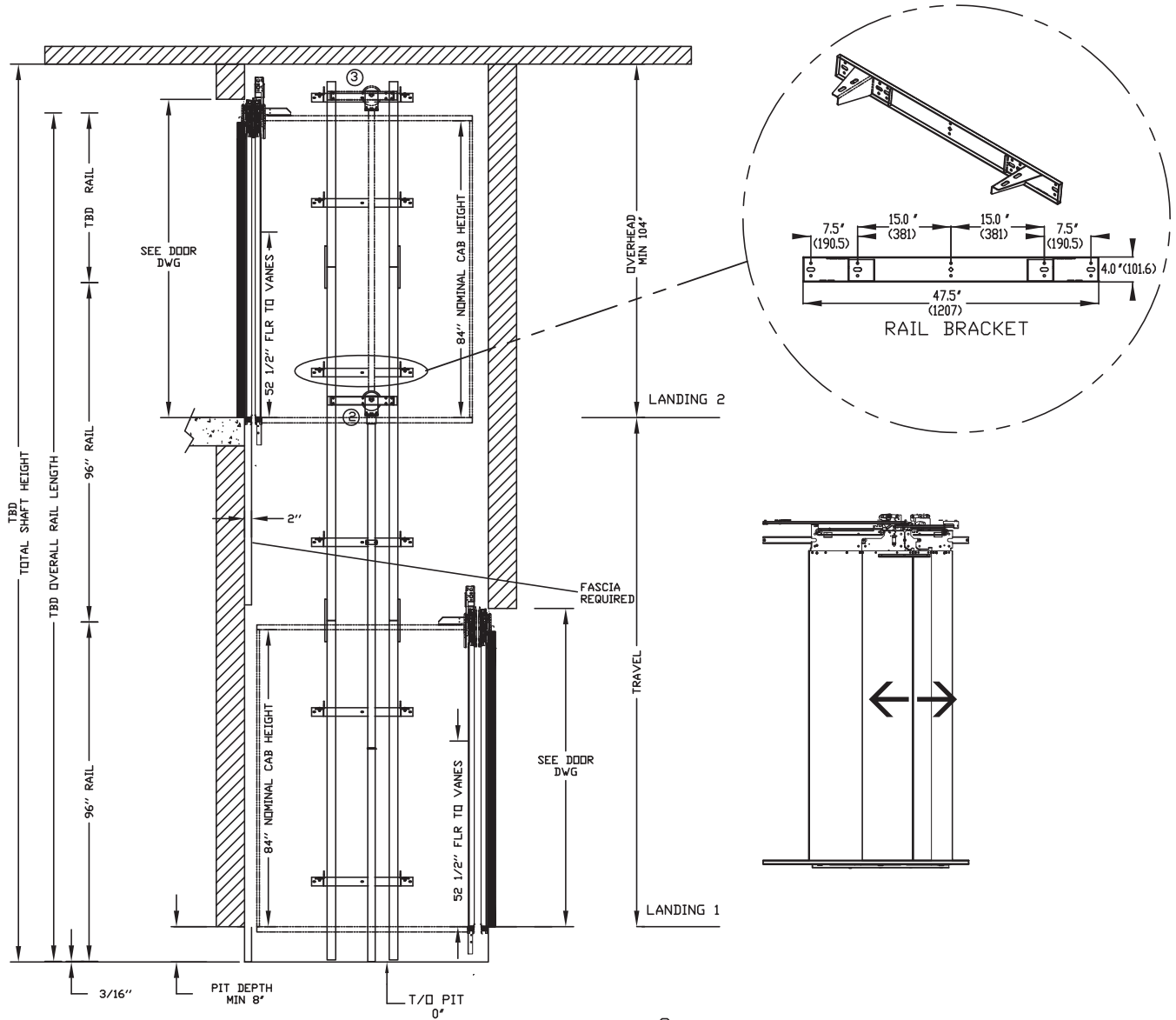

RAIL FORCES	
*R1	*R2
304lbf.	194lbf.
RAIL WEIGHT : 8.0 lbs / ft	

R3 NOTE:
 PIT FLOOR TO SUPPORT LOAD OF:
 5.6Klps * (INCLUDES IMPACT)
 FOR TOTAL PULL-OUT FORCE ON RAIL BRACKET,
 R1 MUST BE DOUBLED eg.

RAIL BRACKET

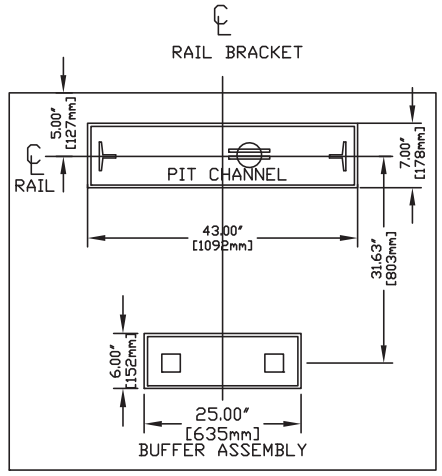

Plan view – Infinity type 2 with auto slim doors

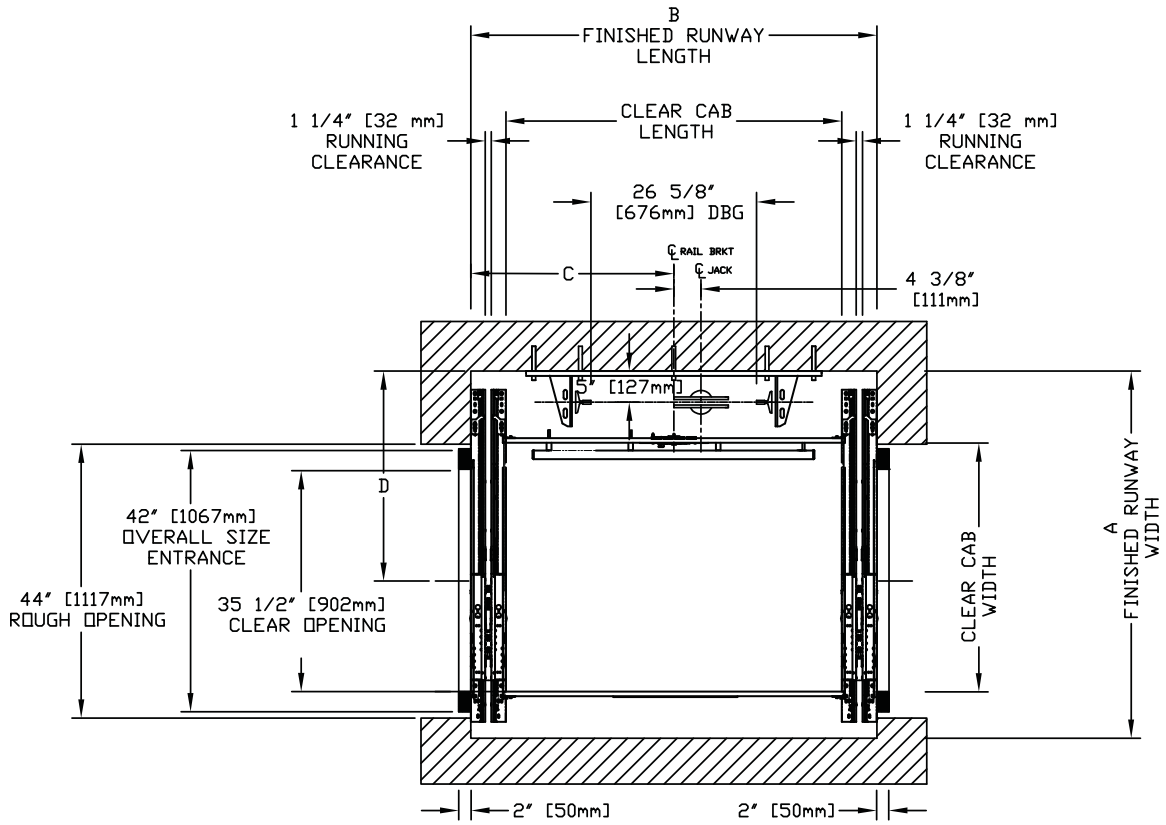

CLEAR INSIDE CAB WIDTH		CLEAR INSIDE CAB LENGTH		A FINISHED RUNWAY WIDTH		B FINISHED RUNWAY LENGTH		C RAIL CENTER LINE		D DOOR CENTER LINE	
mm	Inches	mm		mm	Inches	mm	Inches	mm	Inches	mm	Inches
914	36	1219	48	1499	59	1518	59 3/4	759	29 7/8	838	33.00
914	36	1372	54	1499	59	1670	65 3/4	835	32 7/8	838	33.00
914	36	1524	60	1499	59	1822	71 3/4	911	35 7/8	838	33.00
1016	40	1372	54	1524	60	1670	65 3/4	835	32 7/8	883	34 3/4
1219	48	1524	60	1626	64	1803	71	902	35 1/2	857	33 3/4

HD

Elevation view – Infinity type 3 with auto slim doors

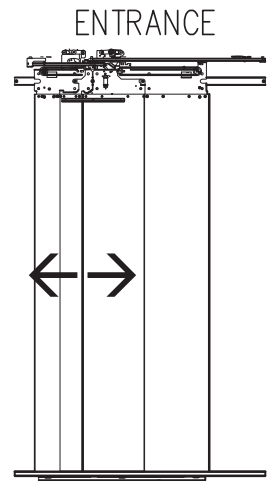
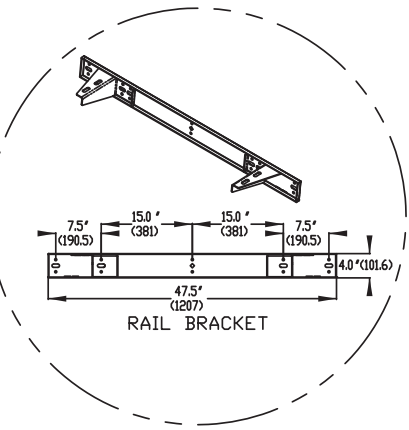
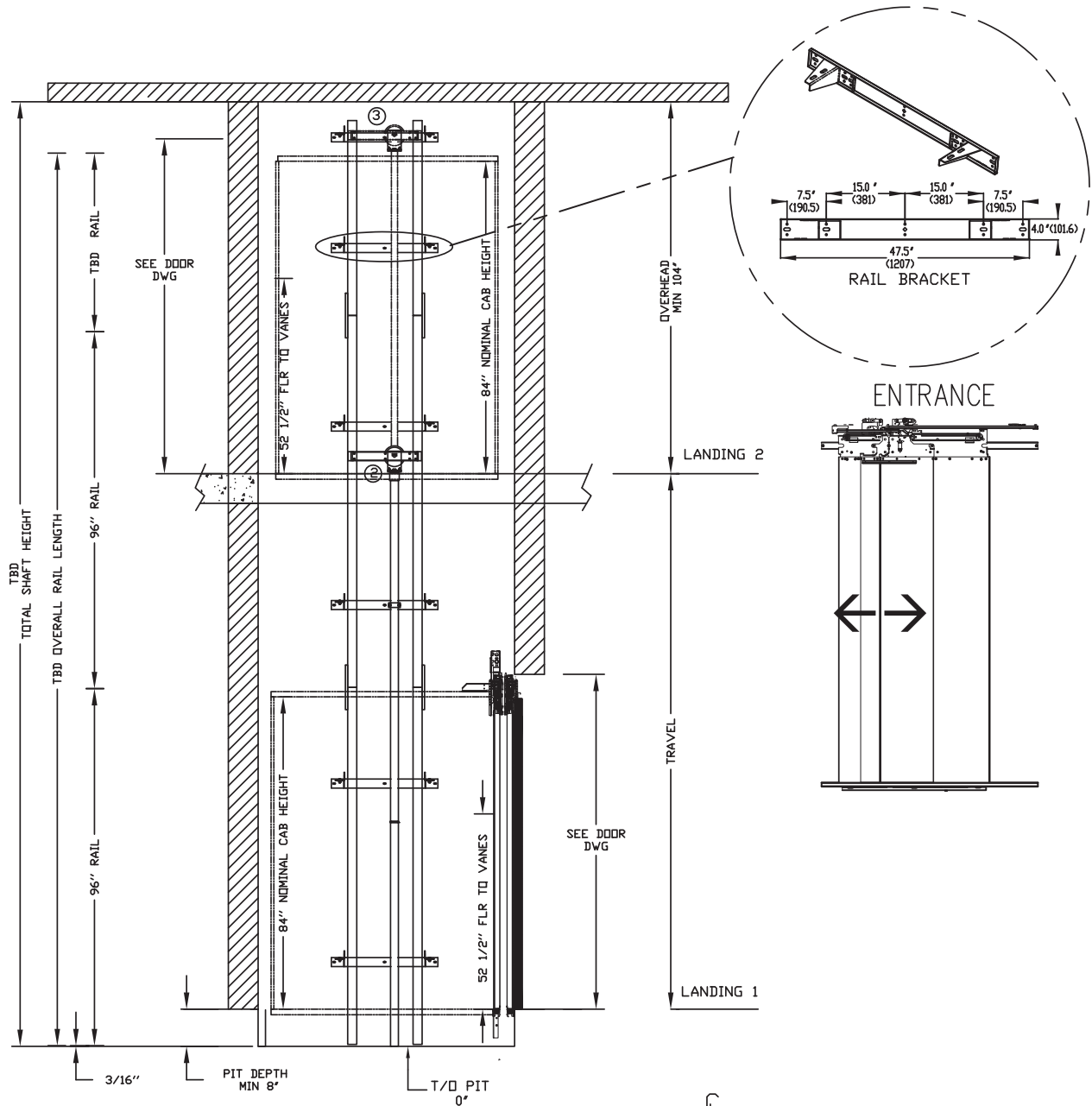

RAIL FORCES	
*R1	*R2
304lbf.	194lbf.
RAIL WEIGHT : 8.0 lbs / ft	

R3 NOTE:
 PIT FLOOR TO SUPPORT LOAD OF:
 5.6Kips * (INCLUDES IMPACT)
 FOR TOTAL PULL-OUT FORCE ON RAIL BRACKET,
 R1 MUST BE DOUBLED eg.

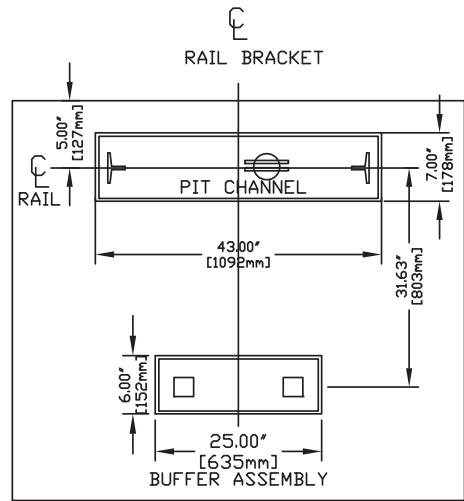

RAIL BRACKET

Plan view – Infinity type 3 with auto slim doors

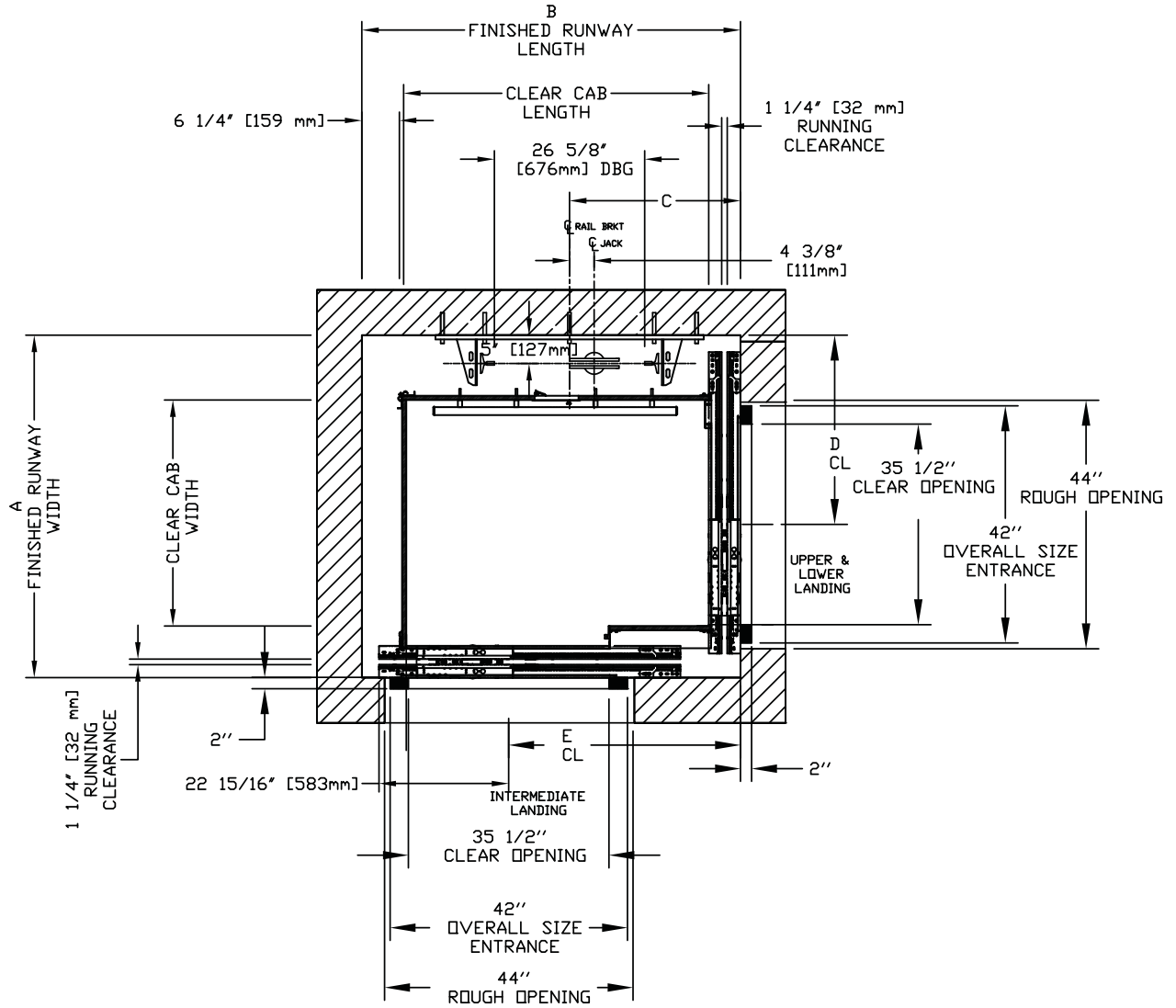

CLEAR INSIDE CAB WIDTH		CLEAR INSIDE CAB LENGTH		A FINISHED RUNWAY WIDTH		B FINISHED RUNWAY LENGTH		C RAIL CENTER LINE		D DOOR CENTER LINE		E DOOR CENTER LINE	
mm	Inches	mm		mm	Inches	mm	Inches	mm	Inches	mm	Inches	mm	Inches
914	36	1372	54	1540	60 5/8	1702	67	826	32.5	838	33	1064	41 7/8
914	36	1524	60	1540	60 5/8	1854	73	902	35.5	838	33	1216	47 7/8
1016	40	1372	54	1581	62 1/4	1702	67	826	32.5	883	34 3/4	1064	41 7/8
1219	48	1524	60	1759	69 1/4	1778	70	889	35.0	857	33 3/4	768	30 1/4

HD

Elevation view – Infinity type 4 with auto slim doors

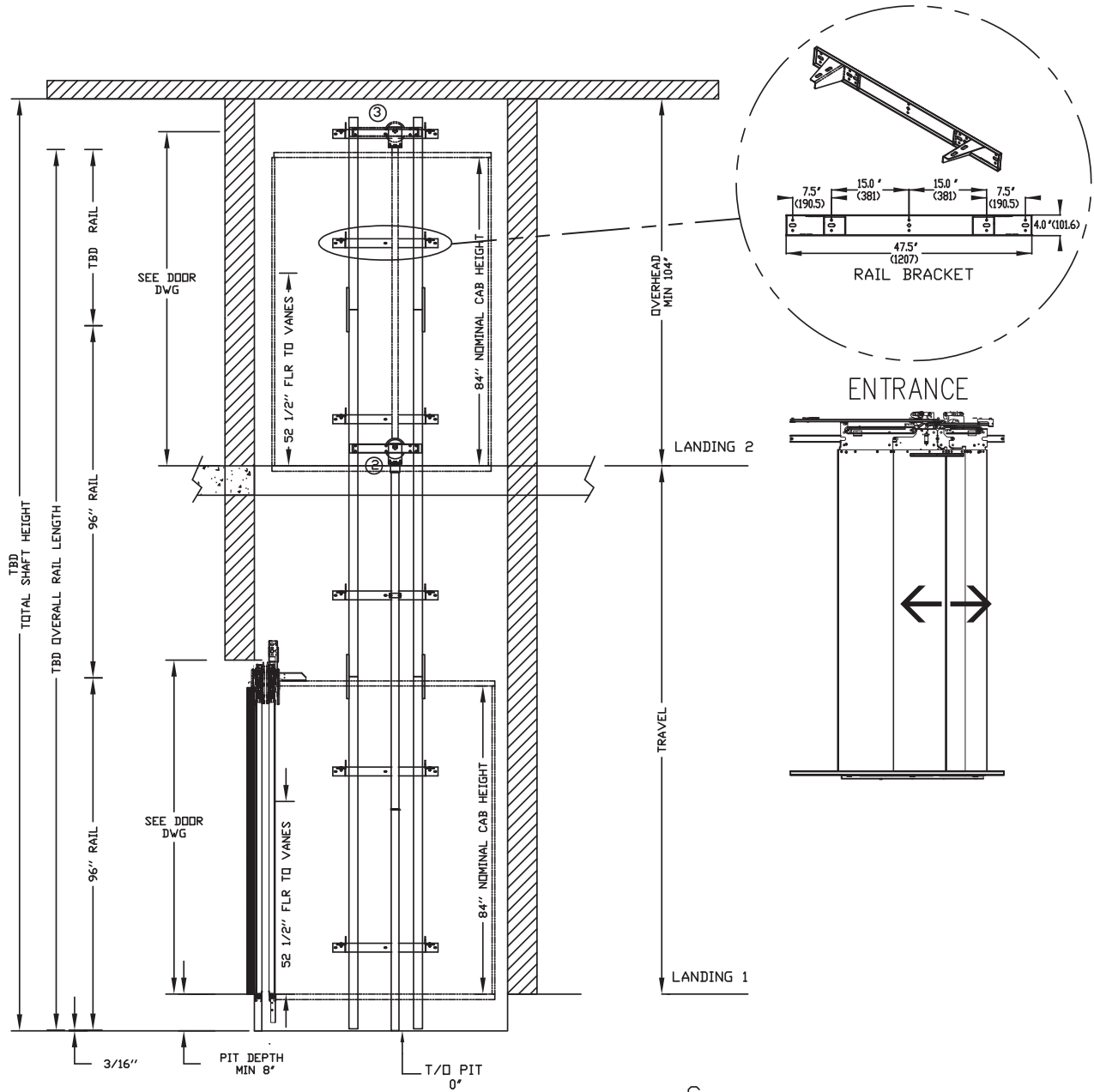

RAIL FORCES	
*R1	*R2
304lbf.	194lbf.
RAIL WEIGHT : 8.0 lbs / ft	

R3 NOTE:
 PIT FLOOR TO SUPPORT LOAD OF:
 5.6Klps * (INCLUDES IMPACT)
 FOR TOTAL PULL-OUT FORCE ON RAIL BRACKET,
 R1 MUST BE DOUBLED eg.

RAIL BRACKET

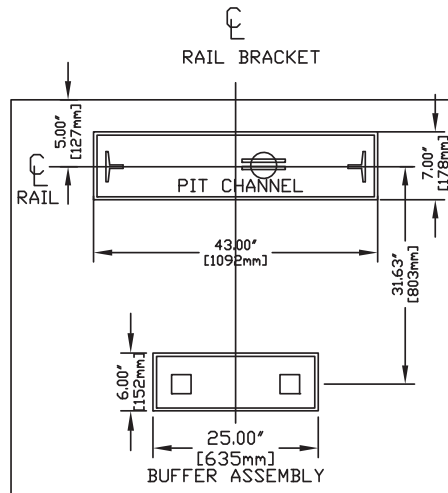

Plan view – Infinity type 4 with auto slim doors

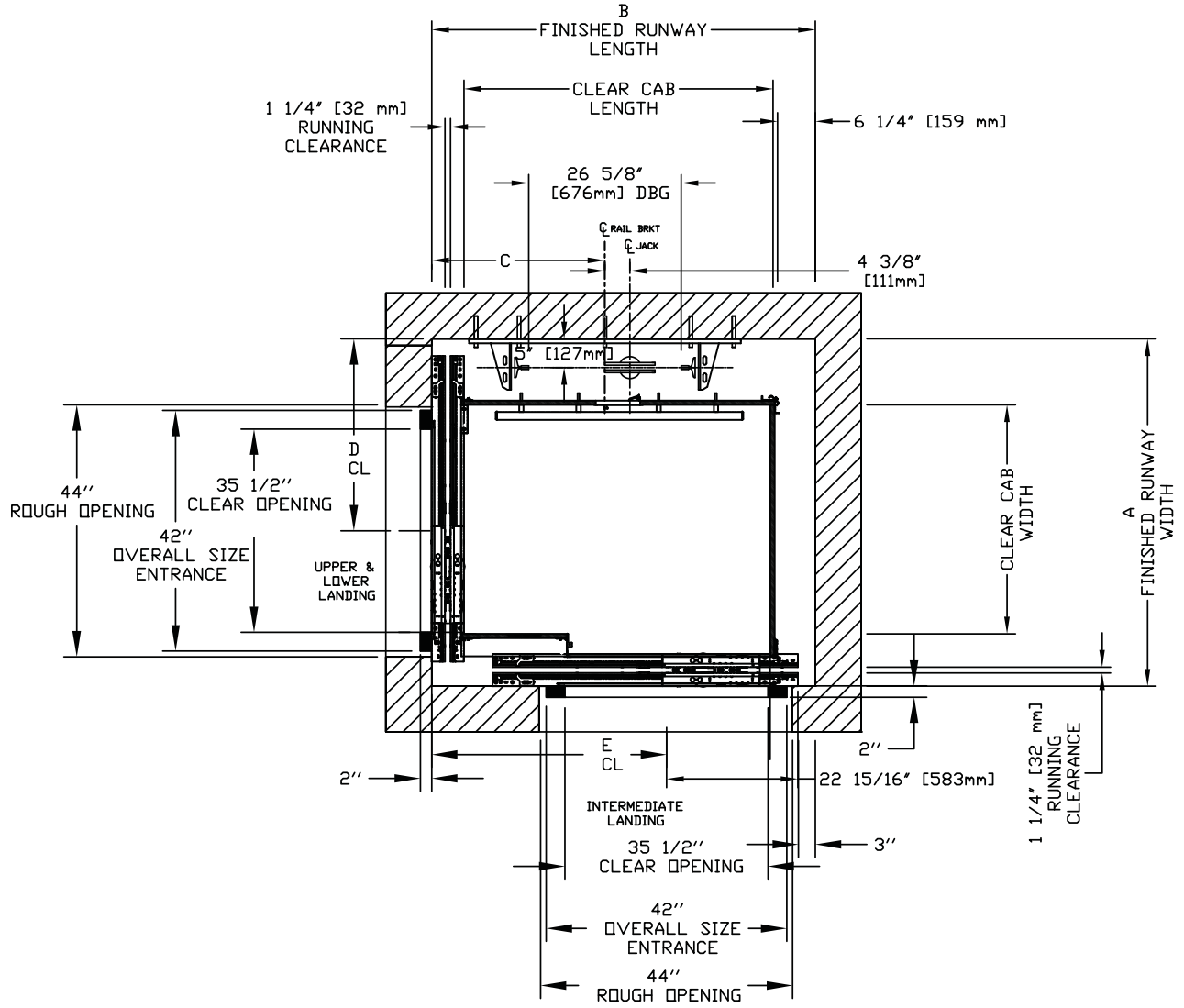

HD

CLEAR INSIDE CAB WIDTH		CLEAR INSIDE CAB LENGTH		A FINISHED RUNWAY WIDTH		B FINISHED RUNWAY LENGTH		C RAIL CENTER LINE		D DOOR CENTER LINE		E DOOR CENTER LINE	
mm	Inches	mm		mm	Inches	mm	Inches	mm	Inches	mm	Inches	mm	Inches
914	36	1372	54	1540	60 5/8	1702	67	826	32 1/2	838	33	1064	41 7/8
914	36	1524	60	1540	60 5/8	1854	73	902	35 1/2	838	33	1216	47 7/8
1016	40	1372	54	1581	62 1/4	1702	67	826	32 1/2	883	34 3/4	1064	41 7/8
1219	48	1524	60	1759	69 1/4	1778	70	889	35	857	33 3/4	768	30 1/4

Elevation view – Infinity type 5 with auto slim doors

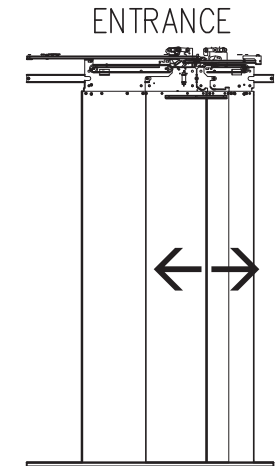
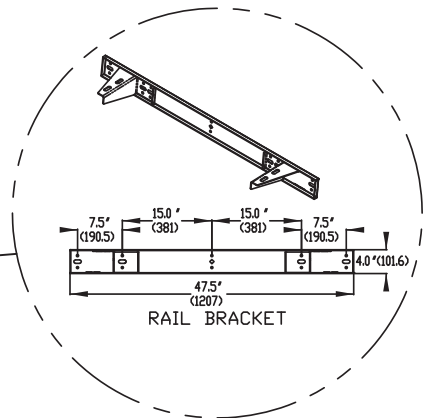
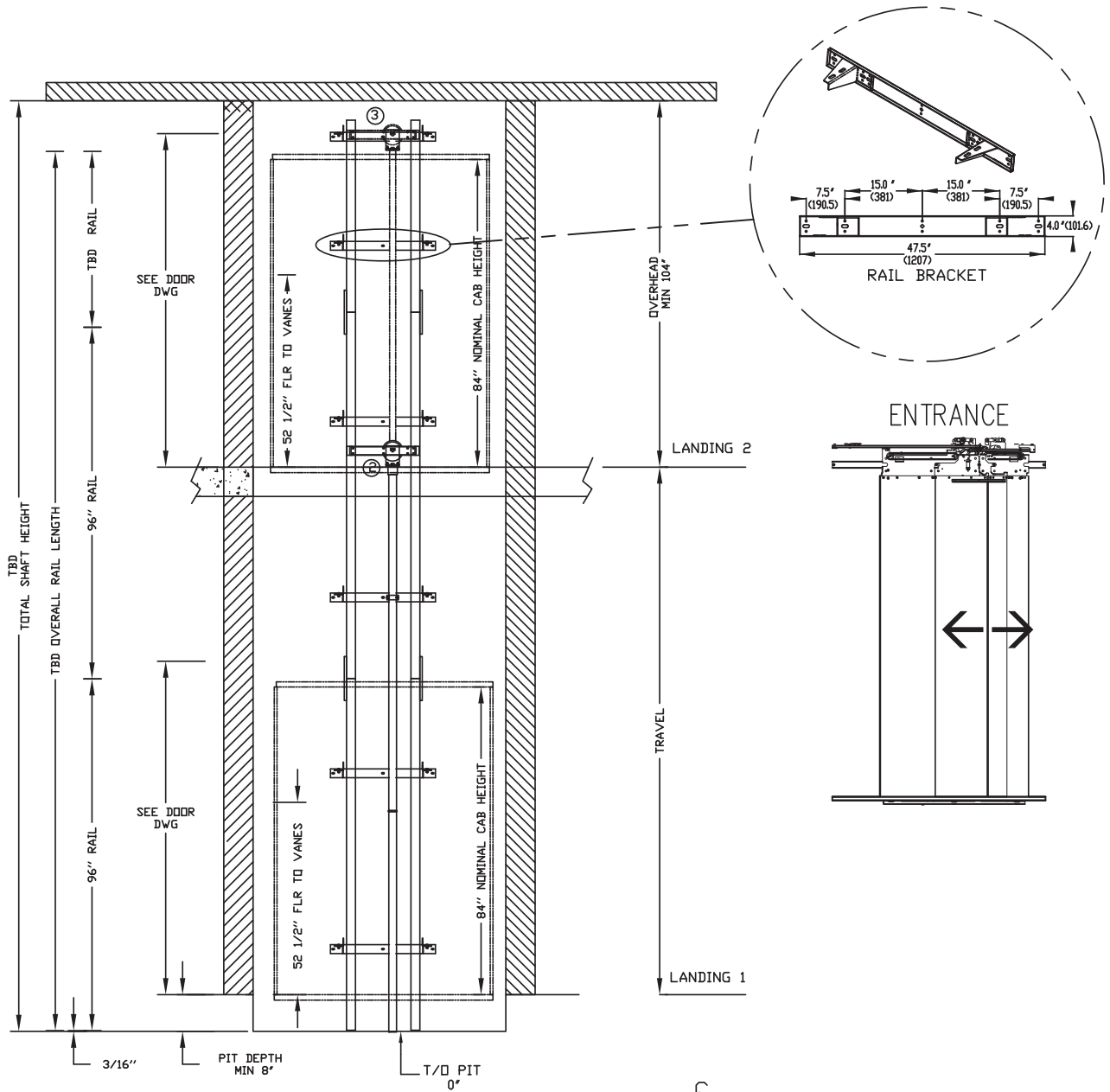

RAIL FORCES	
*R1	*R2
304lbf.	194lbf.
RAIL WEIGHT : 8.0 lbs / ft	

R3 NOTE:
 PIT FLOOR TO SUPPORT LOAD OF:
 5.6Klps * (INCLUDES IMPACT)
 FOR TOTAL PULL-OUT FORCE ON RAIL BRACKET,
 R1 MUST BE DOUBLED eg.

RAIL BRACKET

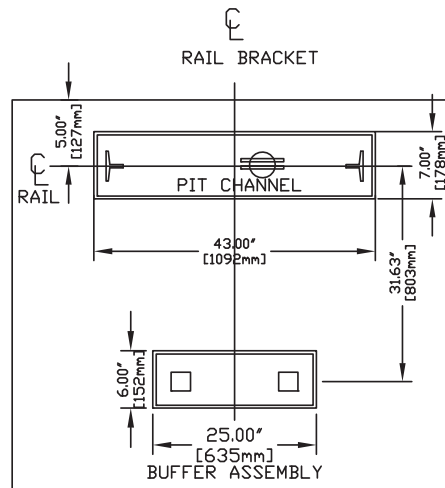

Plan view – Infinity type 5 with auto slim doors

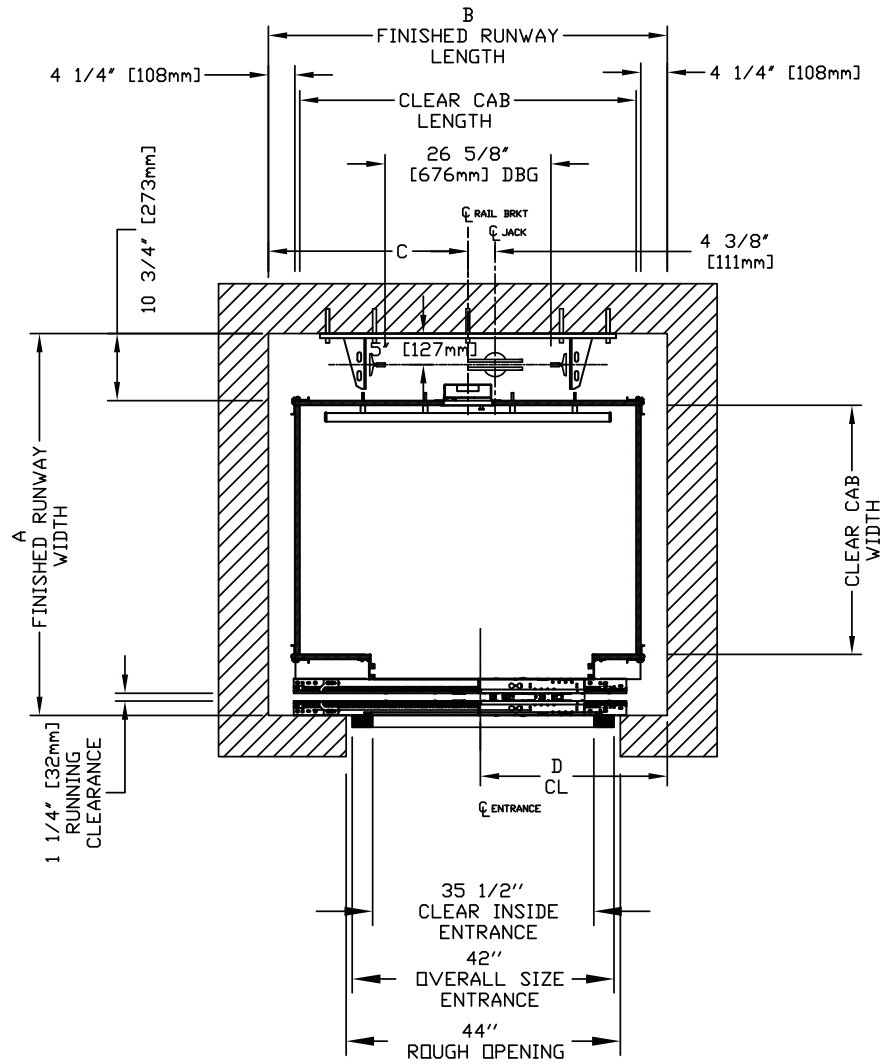

CLEAR INSIDE CAB WIDTH		CLEAR INSIDE CAB LENGTH		A FINISHED RUNWAY WIDTH		B FINISHED RUNWAY LENGTH		C RAIL CENTER LINE		D DOOR CENTER LINE	
mm	Inches	mm	mm	mm	Inches	mm	Inches	mm	Inches	mm	Inches
914	36	1372	54	1454	57 1/4	1626	64	813	32	762	30
914	36	1524	60	1454	57 1/4	1778	70	889	35	762	30
1016	40	1372	54	1556	61 1/4	1626	64	813	32	762	30
HD 1219	48	1524	60	1759	69 1/4	1778	70	889	35	889	35



2 Walker Drive
Brampton, ON Canada L6T 5E1
Phone: 905-791-5555
Fax: 905-791-2222
Sales: 800-661-5112
www.savaria.com