



Eclipse
Residential
Elevator

Planning
Guide

© savaria.

Applicable Codes:

ASME A17.1/CSA-B44

Safety Code for Elevators and Escalators

Section 5.3 – Private Residential Elevators

IMPORTANT NOTICE

This Planning Guide provides nominal dimensions and specifications useful for the initial planning of a project. Before beginning actual construction, make sure you have the installation (shop) drawings customized with specifications and dimensions for your specific project.

Lift configurations and dimensions are in accordance with our interpretation of the standards set forth by the codes listed on the front cover of this Planning Guide. Please consult Savaria or the authorized Savaria dealer in your area for more specific information pertaining to your project, including any discrepancy between referenced standards and those of any local codes or laws.

The dimensions and specifications in this Planning Guide are subject to change (without notice) due to product enhancements and continually evolving codes and product applications.

Visit our website www.savaria.com for the most current Eclipse drawings and dimensions.

Purpose of this guide

This guide assists architects, contractors, and lift professionals to incorporate the Eclipse Residential Elevator into a residential building design. The design and manufacture of the Eclipse Residential Elevator meets the requirements of the following codes and standards:

- ASME A17.1/CSA B44 2000, Section 5.3
- ASME A17.1/CSA B44 2004, Section 5.3
- ASME A17.1 2004, Addendum 2005, Section 5.3
- ASME A17.1/CSA B44 2007, Section 5.3
- ASME A17.1/CSA B44, Addendum 2008, Section 5.3
- ASME A17.1/CSA B44 2010, Section 5.3
- ASME A17.1/CSA B44 2013, Section 5.3
- ASME A17.1/CSA B44 2016, Section 5.3
- ASME A17.1/CSA B44 2019, Section 5.3
- ASME A17.1 1996, Part 5

We recommend that you contact your local authority having jurisdiction to ensure that you adhere to all local rules and regulations pertaining to residential elevators.

How to use this guide

- 1 Determine your client's intended use of the lift.
- 2 Determine the local code requirements.
- 3 Determine the site installation parameters.
- 4 Determine the cab type and hoistway size requirements.
NOTE: If the Eclipse has Auto Slim Doors, do not refer to the tables on pages 6 and 7; refer to Appendix A.
- 5 Plan for electrical requirements.

Revision history this guide

- April 2, 2008 – Added rail forces
- July 31, 2008 – Added rail forces diagram
- January 8, 2008 – Added component weights to specifications; modified center of door for type 5 center
- June 4, 2009 – Added WARNING on page 6 not to install pipes conveying steam, gas or liquid in hoistway
- June 23, 2009 – Added dimension to structural view drawing Figure 1-11 on page 8
- September 25, 2009 – Corrected power supply and lighting supply specifications on pages 2, 12, 13 and 14
- February 9, 2010 – Added recommended manufacturers for circuit breakers at the distribution panel on page 12
- March 31, 2010 – Corrected Type 3 cab measurements on page 4; Corrected Type 4 cab measurements on page 5
- September 9, 2010 – Added note at bottom of tables on pages 4 and 5; Corrected Type 5 cab measurements on page 5; Corrected controller and brake resistor dimensions on page 13
- February 23, 2011 – Added note to step 4 above under “How to use this guide”; Reformatted specifications table on pages 4 and 5; Added “Auto slim doors” to “Options” in specification table on page 5; Updated IMPORTANT note at bottom of pages 6 and 7; Added Appendix A with Auto Slim Doors planning information
- April 25, 2011 – Updated standard features and options in specifications table on pages 4 and 5; Updated Auto Slim Door entrance assembly and elevation drawings in Appendix A
- July 20, 2011 – Updated to 6 stops in specifications table on page 4
- August 12, 2011 – Revised Slim Door drawings on pages 18 and 19
- August 24, 2011 – Removed 208V reference throughout manual
- September 15, 2011 – Revised Slim Door drawings on pages 18 and 19
- October 11, 2011 – Clarified the meaning of “centerline” in the drawings on pages 10 and 11
- October 21, 2011 – Corrected the “Center of door B” dimensions in Tables for Type 3 and Type 4 cabs on pages 6 and 7
- August 30, 2012 – Revised slim door drawings on pages 20 - 30
- October 9, 2012 – Removed motor brake resistor from drawing on page 15
- November 6, 2012 – Added door recommendation on page 13
- December 3, 2012 – Revised note at bottom of Electrical Requirements on page 14
- February 21, 2013 – Changed pot lights from incandescent to halogen in specifications table on page 4
- April 25, 2013 – Revised options in specifications table on page 5
- July 8, 2013 – Added Noise Level to specifications table on page 4
- October 21, 2013 – Revised power supply info in specs table on page 4 & electrical requirements on page 14
- March 13, 2014 – Revised specifications table on pages 4 and 5
- April 29, 2014 – Revised “rough opening” dimension in drawings on pages 18, 20, 22, 24, 26, 28, and 30; Changed “Minimum Overhead” spec on page 4 from 114” to 112” for 96” cab
- August 29, 2014 – Added controller box dimensions on page 16
- November 5, 2014 – Revised Applicable codes on page 3
- March 4, 2015 – Revised drawing on page 15
- August 31, 2015 – Revised load capacity spec on page 4
- September 24, 2015 – Added Daily Cycle to specifications table on page 4
- March 2, 2016 – Removed copyright from cover page; Savaria Corporation back to Savaria Concord Lifts, Inc.
- June 15, 2016 – Revised electrical requirements on page 14
- January 25, 2017 – Added new code on page 3; Revised specs table on pages 4 and 5; Added new 3/4 & 4 safety rule and moved safety rules to pages 6 to 9
- February 9, 2017 – Added spec for distance between landings to specs table on page 4
- March 14, 2017 – Revisions throughout; page layout change for bi-fold door and small auto slim door cab plan views
- May 29, 2017 – Revised cab width in tables on pages 10 and 11 (cabs with panel-fold doors)
- March 14, 2018 – Revised pit depth to 8” on pages 4 and 27
- July 10, 2018 – Revised overhead for bi-fold doors to 96” on page 13
- August 1, 2018 – Revised forces on pages 4 and 30
- April 22, 2019 – Removed reference to “vaness” in drawings on pages 13 and 18
- June 26, 2019 - Added P/N for measuring tool on page 8
- July 12, 2019 - Revised overhead for auto slim doors to 100” (pages 4 and 18)
- October 9, 2019 - Revised specifications table on page 5
- November 22, 2019 - Revised specifications table on page 4 (pit depth requirement)
- December 31, 2019 - Revised drawings on pages 14, 15 and 16
- January 9, 2020 - Added note to temperature spec on page 4
- January 16, 2020 - Added outdoor hall call and Savaria Link to options in spec table on page 5: Added provisions by others - Savaria Link option on page 33
- May 5, 2020 - Revised Distance Between Floors spec on page 4
- May 12, 2020 - Added new spec “floor by others (in cab)” to specs table on page 4
- July 10, 2020 - Added 2019 code on page 2; Added plan views for bi-fold doors type 3 and 4 on page 17
- August 11, 2020 - Revised max travel spec on page 4
- August 20, 2020 - Revised noise spec on page 4
- August 21, 2020 - Revised tables on pages 10 and 11
- September 1, 2020 - Removed 3 & 5 rule
- October 20, 2020 - Added flush wood door instructions on pages 33 through 36
- November 19, 2020 - Updated specifications on page 4
- January 25, 2021 - Revised wall configuration dimension on page 28
- February 2, 2021 - Corrected conversion and added new overhead clearance dimension on page 5
- August 24, 2021 - Updated controller box dimensions on page 32
- September 2, 2021 - Updated Plan views
- August 2 2022 - Updated cover
- August 11, 2023 - Revised wording on pages 8-9, revised graphics on page 12-15
- September 1, 2023 - Revised controller dimensions on page 32

Eclipse specifications

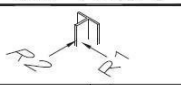
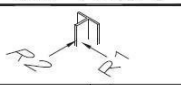
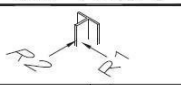
Specification type	Specification data																														
Load capacity	Standard 750 lbs. (341 kg), 950 lbs. (431 kg), and 1000 lbs. (454 kg)																														
Component weights	367 lbs. - sling and base rail section 170 lbs. - middle rail Variable weight - top rail/bed plate 600 lbs. - control wall stack (variable) 440 to 660 lbs. cab (+ 263 lbs. speedy sling) 100 lbs. motor drive 50 lbs. controller 2 lbs. per foot chain (two runs)																														
Rail forces	<div style="display: flex; justify-content: space-around;"> <table border="1" style="border-collapse: collapse; text-align: center;"> <thead> <tr> <th colspan="3">RAIL FORCES</th> </tr> </thead> <tbody> <tr> <td colspan="3"></td> </tr> <tr> <th>*R1</th> <th>*R2</th> <th>PRODUCT</th> </tr> <tr> <td>422 lbf.</td> <td>251 lbf.</td> <td>Eclipse HD</td> </tr> <tr> <td>304 lbf.</td> <td>194 lbf.</td> <td>Eclipse</td> </tr> <tr> <td colspan="3">RAIL WEIGHT: 8.0 lbs. / ft</td> </tr> </tbody> </table> <table border="1" style="border-collapse: collapse; text-align: center;"> <thead> <tr> <th colspan="2">R3 NOTE:</th> </tr> </thead> <tbody> <tr> <td colspan="2">PIT FLOOR TO SUPPORT LOAD OF:</td> </tr> <tr> <td colspan="2">* (INCLUDES IMPACT)</td> </tr> <tr> <th colspan="2">PRODUCT</th> </tr> <tr> <td>8.22 Kips</td> <td>Eclipse HD</td> </tr> <tr> <td>5.6 Kips</td> <td>Eclipse</td> </tr> </tbody> </table> </div> <p style="font-size: small; margin-top: 5px;">FOR TOTAL PULL-OUT FORCE ON RAIL BRACKET, R1 MUST BE DOUBLED eg. 608 lbf. for Eclipse</p>	RAIL FORCES						*R1	*R2	PRODUCT	422 lbf.	251 lbf.	Eclipse HD	304 lbf.	194 lbf.	Eclipse	RAIL WEIGHT: 8.0 lbs. / ft			R3 NOTE:		PIT FLOOR TO SUPPORT LOAD OF:		* (INCLUDES IMPACT)		PRODUCT		8.22 Kips	Eclipse HD	5.6 Kips	Eclipse
RAIL FORCES																															
																															
*R1	*R2	PRODUCT																													
422 lbf.	251 lbf.	Eclipse HD																													
304 lbf.	194 lbf.	Eclipse																													
RAIL WEIGHT: 8.0 lbs. / ft																															
R3 NOTE:																															
PIT FLOOR TO SUPPORT LOAD OF:																															
* (INCLUDES IMPACT)																															
PRODUCT																															
8.22 Kips	Eclipse HD																														
5.6 Kips	Eclipse																														
Rated speed	40 fpm (0.20 mps) standard.																														
Power supply (circuit by others)	230 volt, single phase, 60 Hz, 30-Amp fused disconnect box with 20-Amp fuse																														
Lighting supply (circuit by others)	120 volt, 60 Hz, 2 amps (consumption)																														
Drive system	Automatic 2HP-g geared roller chain variable frequency drive, complete with counterweight																														
Distance between floors	7" (178 mm) minimum (floors 1 to 2, 3 to 4, 5 to 6) 11" (279 mm) minimum (floors 2 to 3, 4 to 5)																														
Temperature operating range (environment)	- 10°C to + 40°C / 14°F to 104°F NOTE: For optimal running conditions, each landing of the unit should be in a climate-controlled environment.																														
Noise level	60 dBA to 63 dBA Measured 10" (254 mm) away from COP at top landing																														
Daily cycle	Normal: 40 Heavy: 80 Excessive: 150 Maximum starts in 1 hour on standard installation: 20 NOTE: Please consult your Sales Representative if there a chance you may exceed these amounts.																														
Cab size	<ul style="list-style-type: none"> • W36" x L48" x H80" (914 mm x 1219 mm x 2032 mm), Type 1, 2, 3, 4, 5 • W36" x L54" x H80" (914 mm x 1371 mm x 2032 mm), Type 1, 2, 3, 4, 5 • W36" x L60" x H80" (914 mm x 1524 mm x 2032 mm), Type 1, 2, 3, 4, 5 • W40" x L54" x H80" (1067mm x 1371 mm x2032 mm), Type 1, 2, 3, 4, 5 																														
Floor by others (in cab)	3/4" (19 mm) maximum																														
Cab panel and finish	Solid melamine or MDF panels (standard), unfinished oak veneer panels (optional), finished recessed veneer panels (optional), solid hardwood raised panels (optional)																														
Maximum travel	50 ft (15.24 m); 60 ft (18.29 m) where a variance is possible																														
Control system	Relay logic controller complete with diagnostic LEDs																														
Levels and openings	Up to 6 stops / up to 2 cab openings																														
Pit depth requirement	Eclipse: 8" (152 mm) minimum Eclipse HD: 10" (254 mm) minimum Optional: with buffer springs - plus 3" (76 mm); with steel cab - plus 1.5" (38 mm)																														

Eclipse specifications (continued)

Specification type	Specification data
Minimum overhead clearance	96" (2438 mm) for standard 80" cab 100" (2540 mm) for 84" cab 112" (2845 mm) for 96" cab 100" (2540 mm) for 84" cab with auto slim doors 112" (2845 mm) for 96" cab with auto slim doors
Hall station and control panel finish	<ul style="list-style-type: none"> • Clear or bronze anodized aluminum (standard), or stainless steel (optional), or brass (optional), or architect white (optional) • Rectangular (standard) or oval (optional) hall stations, keyless (standard) or keyed (optional)
Standard features	<ul style="list-style-type: none"> • Automatic cab on/off lighting • Recessed gate pocket • Digital display in car operating panel • Clear or bronze anodized aluminum cab entrance trim and handrail • Data plates, capacity tags • Proximity floor selection, stopping and two-way levelling • Motor access cover (locked and switched) • Home landing feature • Plan drawings • Modular rail sections • Unfinished plywood sub-floor • White ceiling with four LED lights • MDF cab with or without finish, melamine cab in choice of finishes • Stainless steel, clear or bronze anodized aluminum cab operating panel and hall call stations
Safety features	<ul style="list-style-type: none"> • Cab gate safety switch • Pit run/stop switch and car top run/stop switch • Emergency stop and alarm buttons • Uninterruptible power supply (UPS)/battery back-up system for lowering, automatic gate operation (if equipped), and electrical interlock operation and lighting in the event of a power failure • Upper and lower terminal limits • Final limit switch • Mechanical rail shoring blocks • Sling: factory pre-assembled speedy sling c/w pre-set slack chain safety brake and switch
Options	<ul style="list-style-type: none"> • Custom cab size • 96" (2438 mm) high cab; 84" (2133 mm) high cab • Rated speed - (50 fpm (0.250 mps) available where code permits) • Accordion car gate (choice of style) • Automatic gate operator • Bi-fold doors • Automatic swing landing door operator • Buffer springs (11" pit depth minimum) • Interlocks for doors by others and Savaria landing doors (fire rated door or wood door) • Keyed on/off control panel and hall stations • Optional cab finishes: raised hardwood, unfinished veneer • Optional fixture finishes: brass #4 finish or blackened stainless steel (handrail, cab operating panel, hall call stations); hall call stations available in rectangular or oval • Telephone cabinet to match trim • Automatic slim doors • Digital position indicator (PI) in hall calls • Surface mount hall call for outdoor use • Savaria Link remote monitoring

Safety first – 3/4 & 4 rule

The ASME A17.1-2016/CSA B44-16 Safety Code for Elevators and Escalators (**2016 AND AFTER**) mandates the following maximum hoistway door clearances (see drawing on next page):

- Clearance between the hoistway side of the landing door and the edge of the landing sill shall not exceed 0.75" (19 mm) for swing doors (shown below) and 2.25" (57 mm) for sliding doors.
- Distance between the hoistway side of the landing door or gate and the car door or gate shall not exceed 4" (102 mm). *A measuring tool for this is shown below.*
- Eclipse Residential Elevator design is with a maximum 1.25" (32 mm) running clearance.

NOTE: Concrete block/masonry shafts and some commercial metal door frames often create 3/4 & 4 rule violations.

Recommendation: We recommend installation of a solid door as hollow doors do not respect the pull-out force required by code for the door locks.

IMPORTANT

- If the landing door has a pattern on the hoistway side, measure the 3/4" setback from the deeper part of the door to the landing sill.
- For accordion (panel fold) gates, you **MUST** have flush doors (not the 3/4" setback).
- 3/4" setback is possible only when the car doors are bi-fold or slim doors.

Measuring tool for accordion car gate and landing door (3/4 & 4 rule)



Measuring Tool P/N 301803

With the measuring tool pressed into the "V" of the accordion car gate, the hoistway side of the landing door must not be more than 4" (102 mm) as shown.

3/4 & 4 rule

3/4" & 4" rule

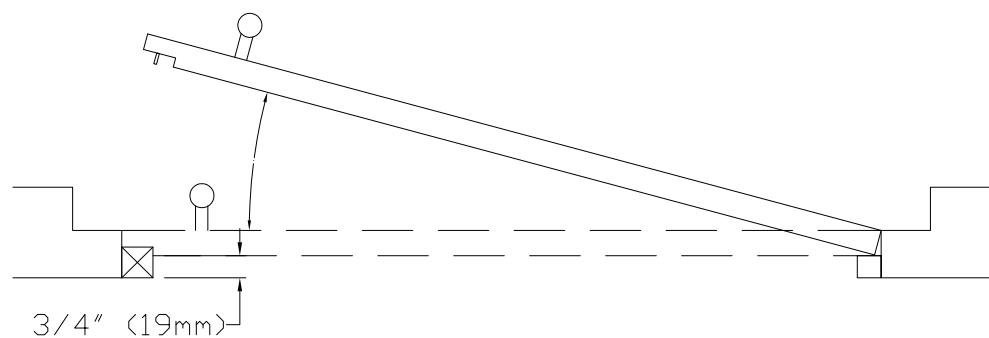
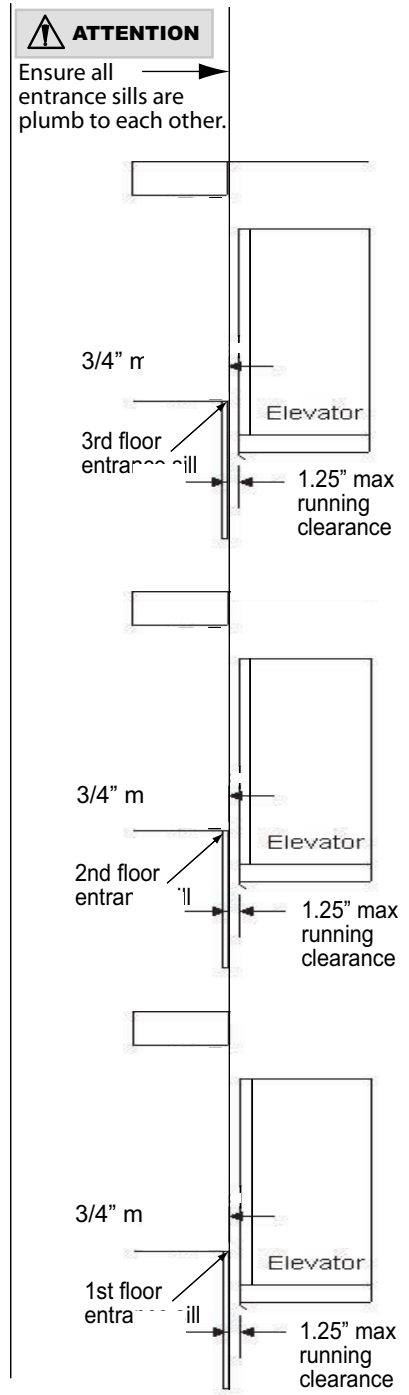
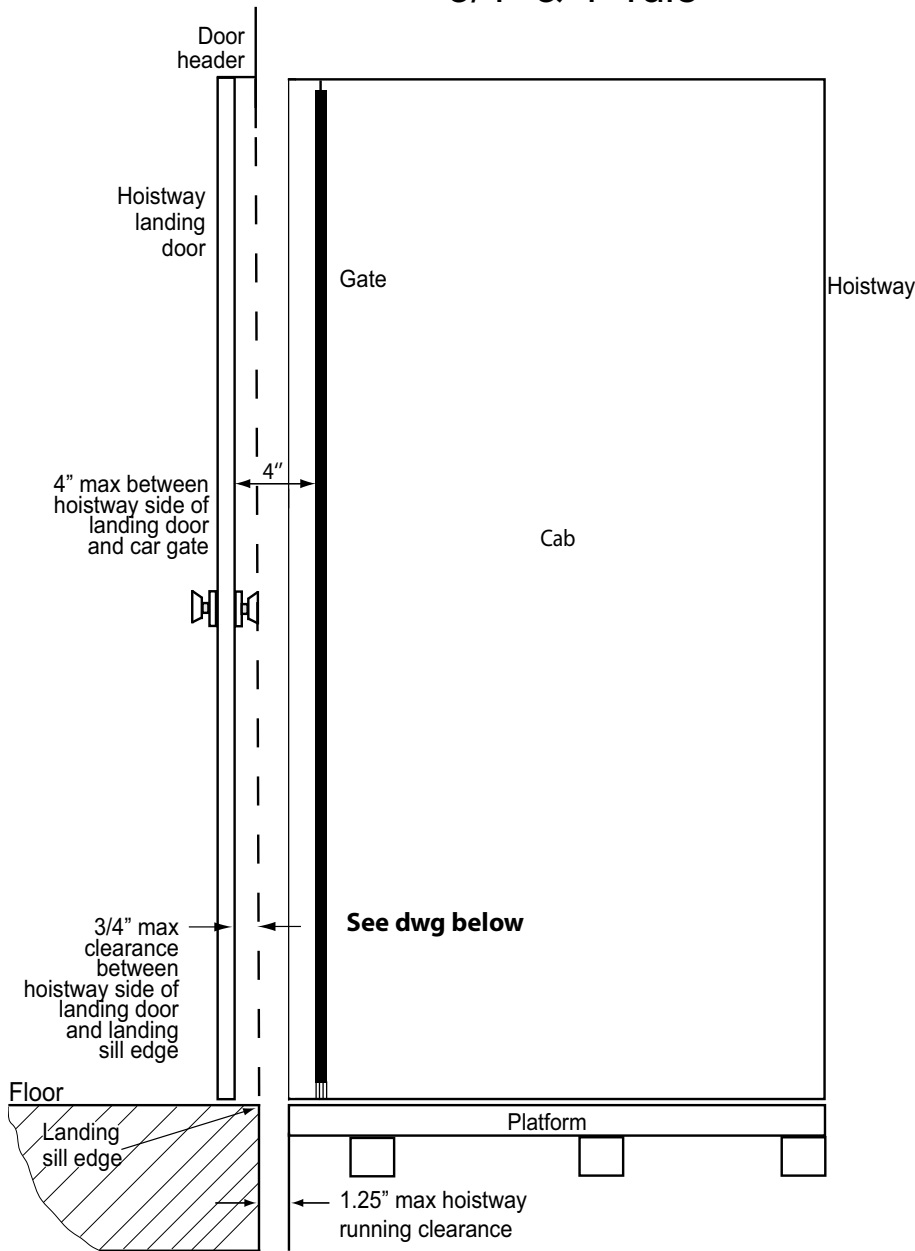

Eclipse with panel-fold doors

Note: All measurements in inches (").

Type 1L (panel-fold doors)

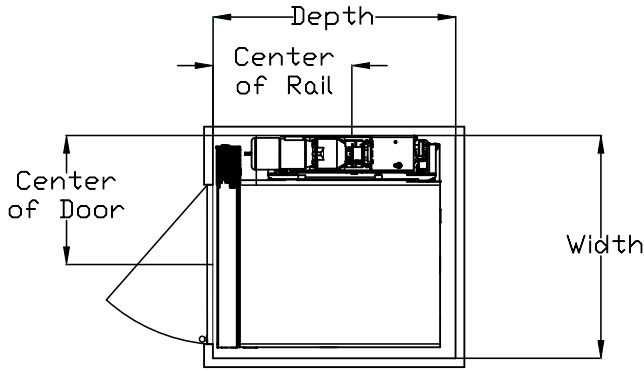

Type 1R (panel-fold doors)

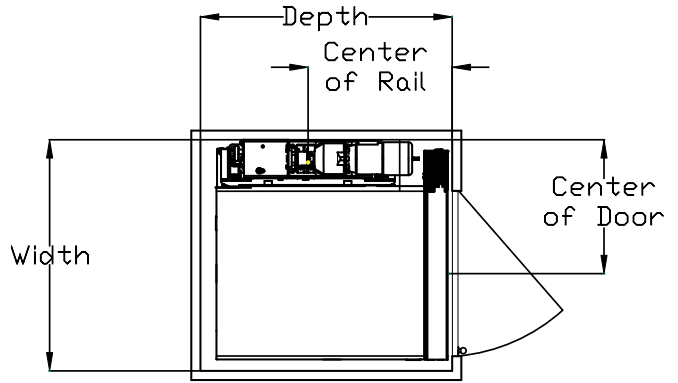

Type 1 left hand

Nominal Cab size	Width	Depth	Center of rail	Center of door
36 x 48	50½	55	31*	29¼
36 x 54	50½	61	33	29¼
36 x 60	50½	67	36	29¼
40 x 54	54½	61	33	33¼

Note: * 30" if right hand motor

Type 1 right hand

Nominal Cab size	Width	Depth	Center of rail	Center of door
36 x 48	50½	55	31*	29¼
36 x 54	50½	61	33	29¼
36 x 60	50½	67	36	29¼
40 x 54	54½	61	33	33¼

Note: * 30" if left hand motor

Type 2 (panel-fold doors)

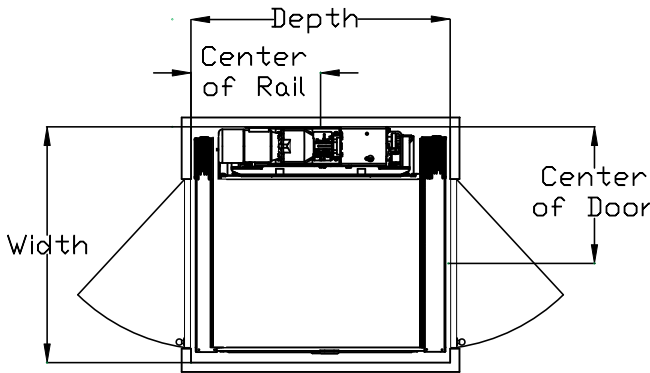

Type 2

Nominal Cab size	Width	Depth	Center of rail	Center of door
36 x 48	50½	55½	27¾	29¼
36 x 54	50½	61½	30¾	29¼
36 x 60	50½	67½	33¾	29¼
40 x 54	54½	61½	30¾	33¼

Type 3 (panel-fold doors)

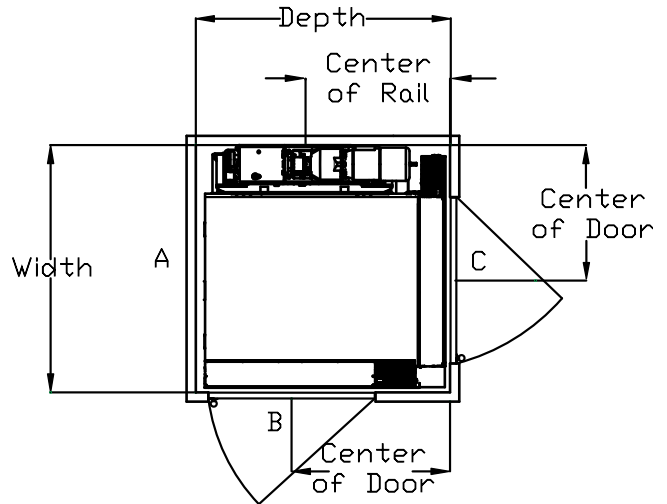

Type 3

Nominal Cab size	Width	Depth	Center of rail	Center of door C	Center of door B
36 x 48	52⅝	55	31	27⅞	34¼
36 x 54	52⅝	61	33	27⅞	38¾
36 x 60	52⅝	67	36	27⅞	46¼
40 x 54	56⅝	61	33	31⅞	38¾

IMPORTANT: Measurements in the above tables are only valid for the cab and hoistway sizes listed. For non-standard cab and/or hoistway sizes, always refer to your plan drawings.

Type 4 (panel-fold doors)

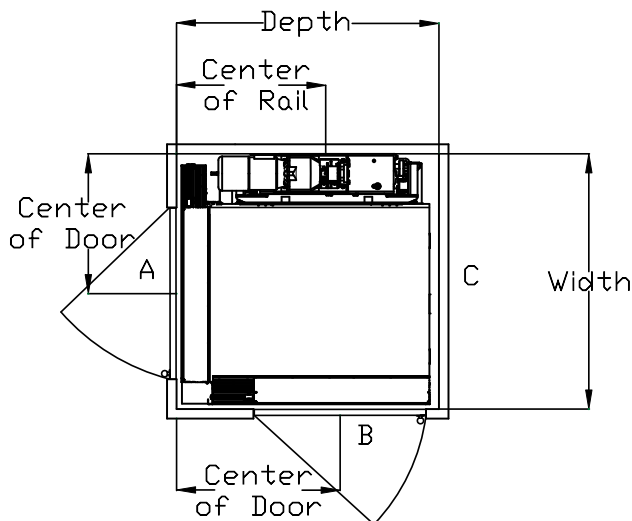

Type 5 center (panel-fold doors)

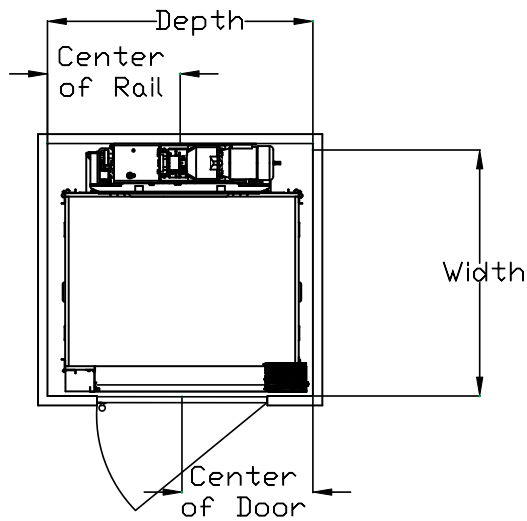

Type 4

Nominal Cab size	Width	Depth	Center of rail	Center of door A	Center of door B
36 x 48	52 ⁵ / ₈	55	31	27 ⁷ / ₈	34 ¹ / ₄
36 x 54	52 ⁵ / ₈	61	33	27 ⁷ / ₈	38 ³ / ₄
36 x 60	52 ⁵ / ₈	67	36	27 ⁷ / ₈	46 ¹ / ₄
40 x 54	56 ⁵ / ₈	61	33	31 ⁷ / ₈	38 ³ / ₄

Type 5 center

Nominal Cab size	Width	Depth	Center of rail	Center of door
36 x 48	52 ⁵ / ₈	56 ¹ / ₄	28 ¹ / ₈	29
36 x 54	52 ⁵ / ₈	62 ¹ / ₄	31 ¹ / ₈	29
36 x 60	52 ⁵ / ₈	68 ¹ / ₄	34 ¹ / ₈	34 ⁵ / ₈
40 x 54	56 ⁵ / ₈	62 ¹ / ₄	31 ¹ / ₈	29

Type 5L (panel-fold doors)

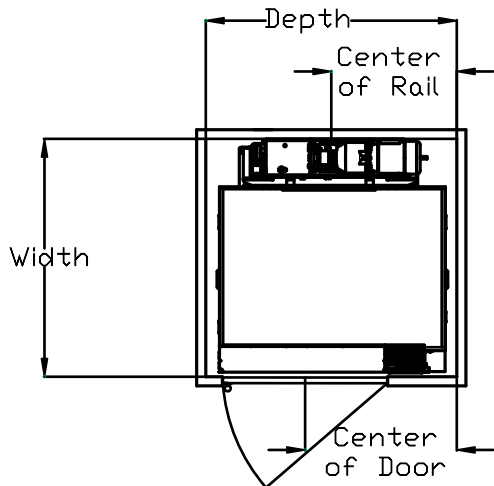

Type 5R (panel-fold doors)

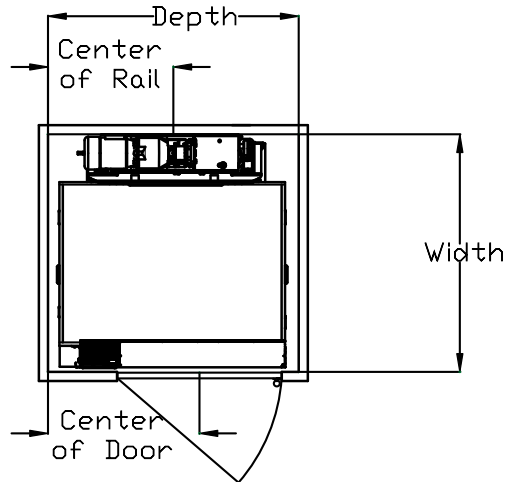

Type 5: left hand

Nominal Cab size	Width	Depth	Center of rail	Center of door
36 x 48	52 ⁵ / ₈	55	27 ¹ / ₂	33 ¹ / ₄
36 x 54	52 ⁵ / ₈	61	30 ¹ / ₂	39 ¹ / ₄
36 x 60	52 ⁵ / ₈	67	33 ¹ / ₂	45 ¹ / ₄
40 x 54	56 ⁵ / ₈	61	30 ¹ / ₂	39 ¹ / ₄

Type 5: right hand

Nominal Cab size	Width	Depth	Center of rail	Center of door
36 x 48	52 ⁵ / ₈	55	27 ¹ / ₂	33 ¹ / ₄
36 x 54	52 ⁵ / ₈	61	30 ¹ / ₂	39 ¹ / ₄
36 x 60	52 ⁵ / ₈	67	33 ¹ / ₂	45 ¹ / ₄
40 x 54	56 ⁵ / ₈	61	30 ¹ / ₂	39 ¹ / ₄

IMPORTANT: Measurements in the above tables are only valid for the cab and hoistway sizes listed. For non-standard cab and/or hoistway sizes, always refer to your plan drawings.

Eclipse with bi-fold doors

Bi-fold doors entrance assembly

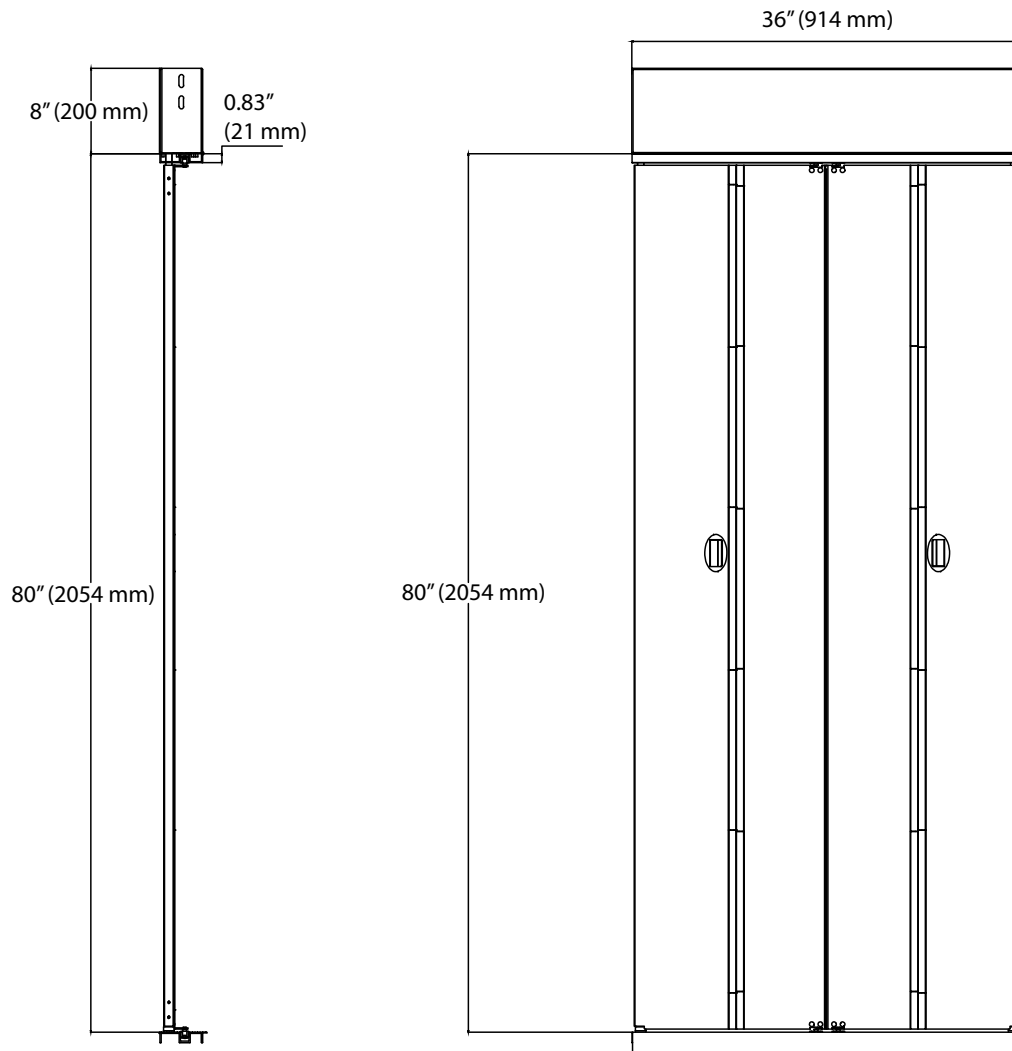

NOTE: Bi-fold doors available in size 36"x80"; white and stainless. Not available for 90 degrees.

Sample elevation view – bi-fold doors (Type 1L shown)

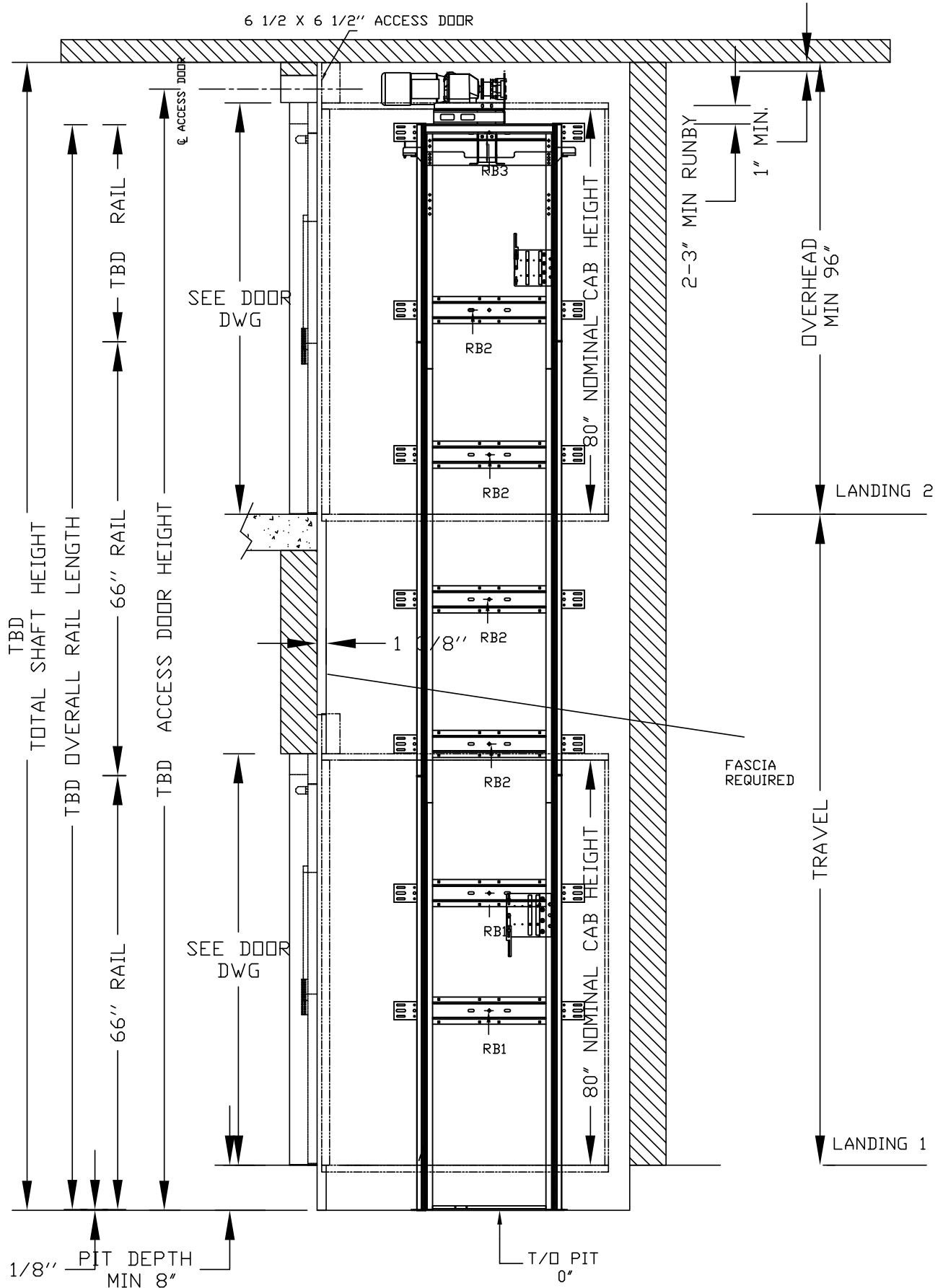

Type 1L (bi-fold doors) - 36" cab width

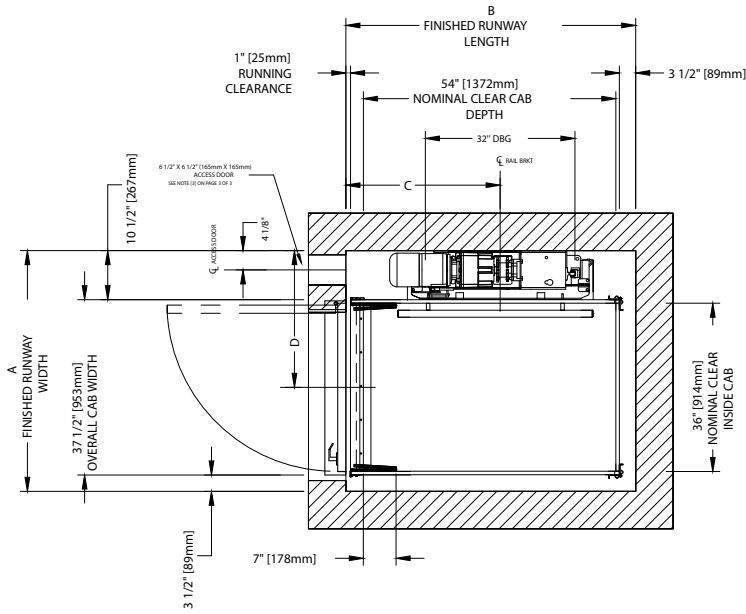

NOMINAL CLEAR INSIDE CAB WIDTH		NOMINAL CLEAR INSIDE CAB LENGTH		A FINISHED RUNWAY WIDTH		B FINISHED RUNWAY LENGTH		C RAIL CENTRE LINE		D DOOR CENTER LINE	
mm	inches	mm		mm	inches	mm	inches	mm	inches	mm	inches
914	36	1219	48	1308	51 1/2	1422	56	762	30	743	29 1/4
914	36	1372	54	1308	51 1/2	1575	62	838	33	743	29 1/4
914	36	1499	59	1308	51 1/2	1702	67	914	36	743	29 1/4

Type 1L (bi-fold doors) - 40" cab width

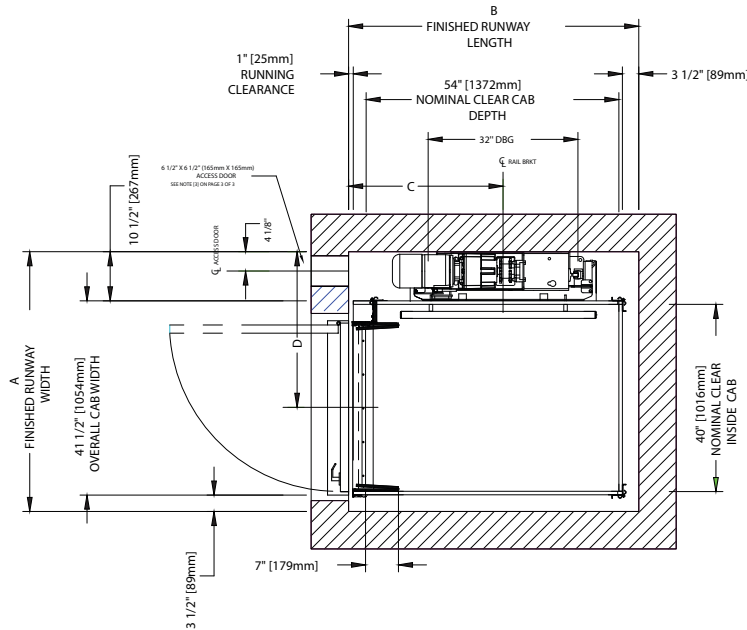

NOMINAL CLEAR INSIDE CAB WIDTH		NOMINAL CLEAR INSIDE CAB LENGTH		A FINISHED RUNWAY WIDTH		B FINISHED RUNWAY LENGTH		C RAIL CENTRE LINE		D DOOR CENTER LINE	
mm	inches	mm		mm	inches	mm	inches	mm	inches	mm	inches
1016	40	1219	48	1410	55 1/2	1422	56	762	30	743	33 1/4
1016	40	1372	54	1410	55 1/2	1575	62	838	33	743	33 1/4
1016	40	1499	59	1410	55 1/2	1702	67	914	36	743	33 1/4

Type 1R (bi-fold doors) - 36" cab width

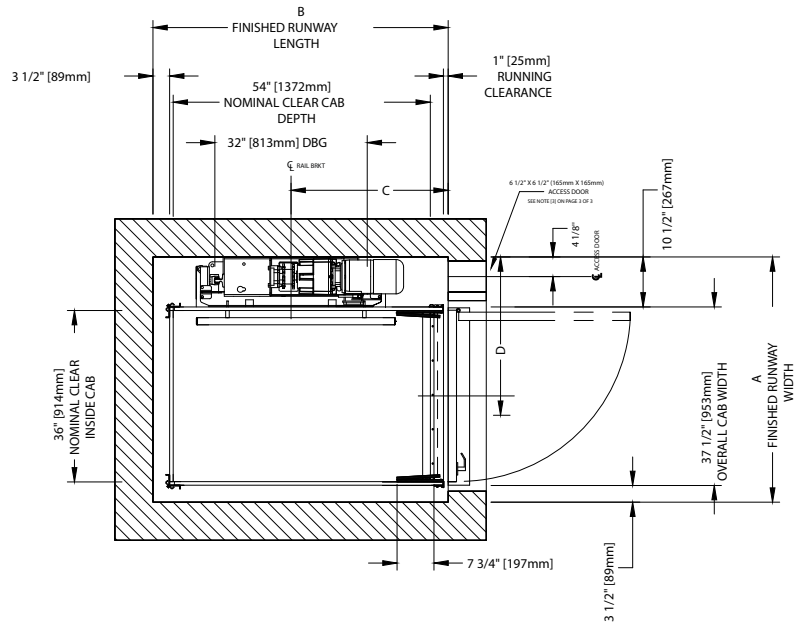

NOMINAL CLEAR INSIDE CAB WIDTH		NOMINAL CLEAR INSIDE CAB LENGTH		A FINISHED RUNWAY WIDTH		B FINISHED RUNWAY LENGTH		C RAIL CENTRE LINE		D DOOR CENTER LINE	
mm	inches	mm		mm	inches	mm	inches	mm	inches	mm	inches
914	36	1219	48	1308	51 1/2	1422	56	762	30	743	29 1/4
914	36	1372	54	1308	51 1/2	1575	62	838	33	743	29 1/4
914	36	1499	59	1308	51 1/2	1702	67	914	36	743	29 1/4

Type 1R (bi-fold doors) - 40" cab width

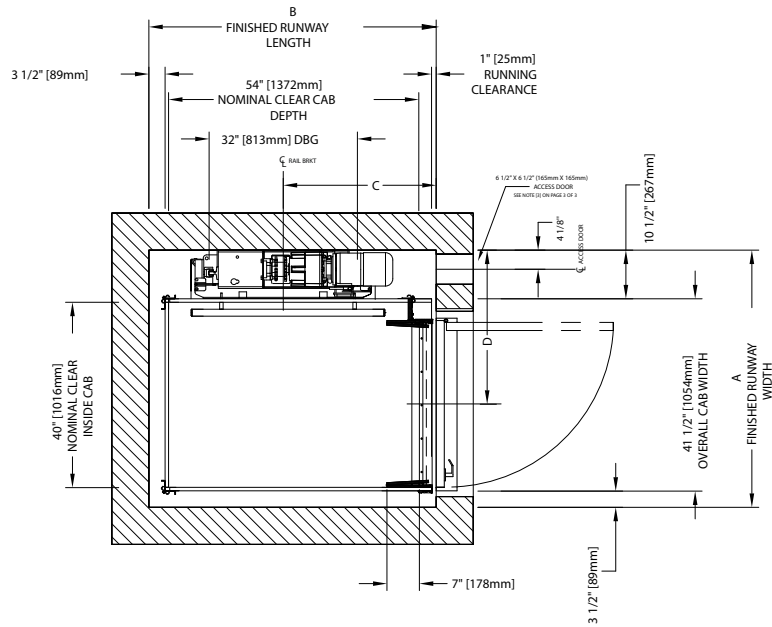

NOMINAL CLEAR INSIDE CAB WIDTH		NOMINAL CLEAR INSIDE CAB LENGTH		A FINISHED RUNWAY WIDTH		B FINISHED RUNWAY LENGTH		C RAIL CENTRE LINE		D DOOR CENTER LINE	
mm	inches	mm		mm	inches	mm	inches	mm	inches	mm	inches
1016	40	1219	48	1410	55 1/2	1422	56	762	30	845	33 1/4
1016	40	1372	54	1410	55 1/2	1575	62	838	33	845	33 1/4
1016	40	1499	59	1410	55 1/2	1702	67	914	36	845	33 1/4

Type 2 (bi-fold doors) - 36" cab width

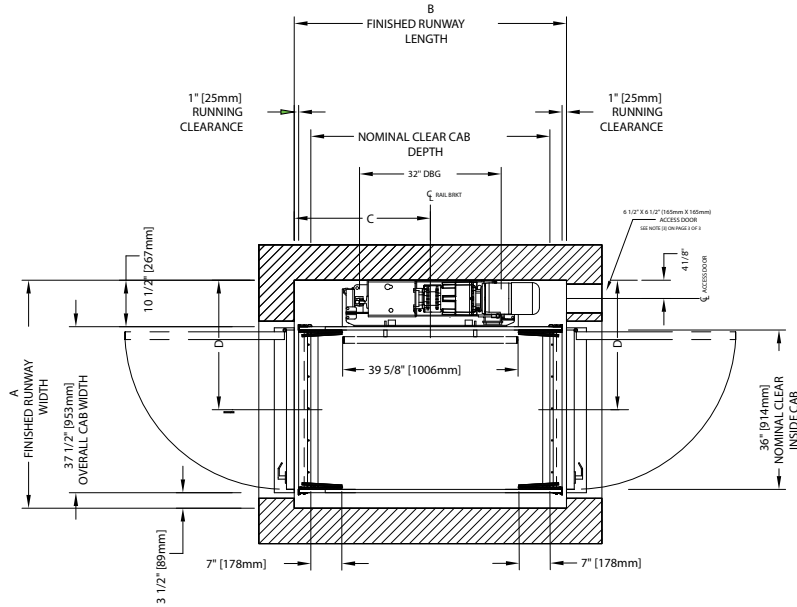

NOMINAL CLEAR INSIDE CAB WIDTH		NOMINAL CLEAR INSIDE CAB LENGTH		A FINISHED RUNWAY WIDTH		B FINISHED RUNWAY LENGTH		C RAIL CENTRE LINE		D DOOR CENTER LINE	
mm	inches	mm		mm	inches	mm	inches	mm	inches	mm	inches
914	36	1219	48	1308	51 1/2	1410	55 1/2	705	27 3/4	743	29 1/4
914	36	1372	54	1308	51 1/2	1562	61 1/2	781	30 3/4	743	29 1/4
914	36	1499	59	1308	51 1/2	1689	66 1/2	845	33 1/4	743	29 1/4

Type 2 (bi-fold doors) - 40" cab width

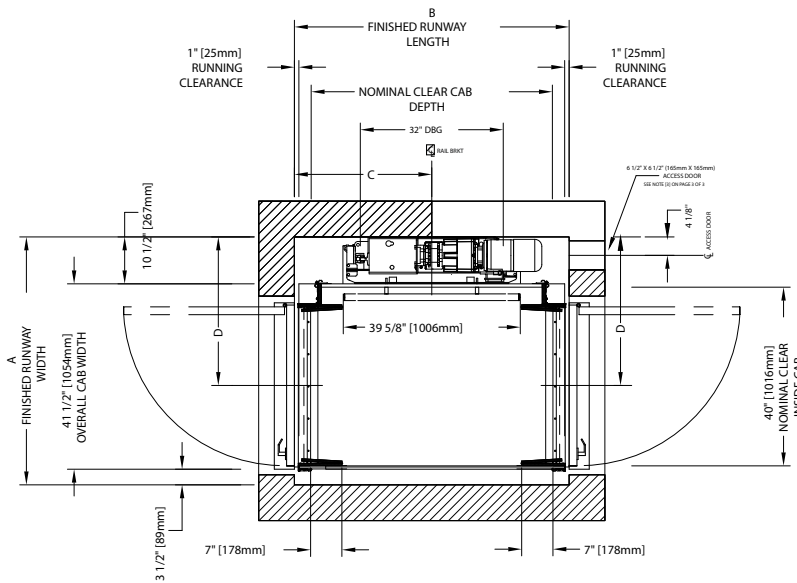

NOMINAL CLEAR INSIDE CAB WIDTH		NOMINAL CLEAR INSIDE CAB LENGTH		A FINISHED RUNWAY WIDTH		B FINISHED RUNWAY LENGTH		C RAIL CENTRE LINE		D DOOR CENTER LINE	
mm	inches	mm		mm	inches	mm	inches	mm	inches	mm	inches
1016	40	1219	48	1410	51 1/2	1410	55 1/2	705	27 3/4	743	33 1/4
1016	40	1372	54	1410	51 1/2	1562	61 1/2	781	30 3/4	743	33 1/4
1016	40	1499	59	1410	51 1/2	1689	66 1/2	845	33 1/4	743	33 1/4

Type 3(bi-fold doors) - 36" cab width

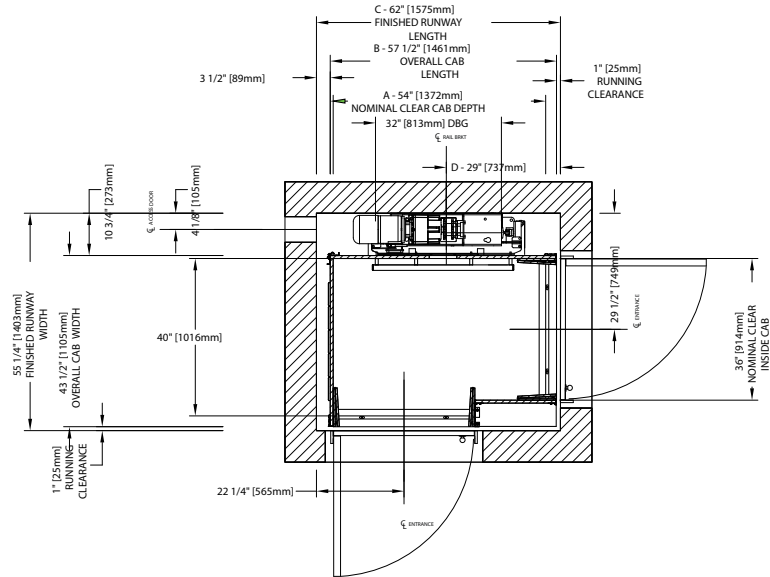

A NOMINAL CLEAR INSIDE CAB LENGTH		B OVERALL CAB LENGTH		C FINISHED RUNWAY LENGTH		D RAIL CENTRE LINE	
mm	inches	mm		mm	inches	mm	inches
1219	48	1308	51 1/2	1422	56	660	26
1372	54	1461	57 1/2	1575	62	737	29
1524	60	1613	63 1/2	1702	67	864	34

Type 4(bi-fold doors) - 36" cab width

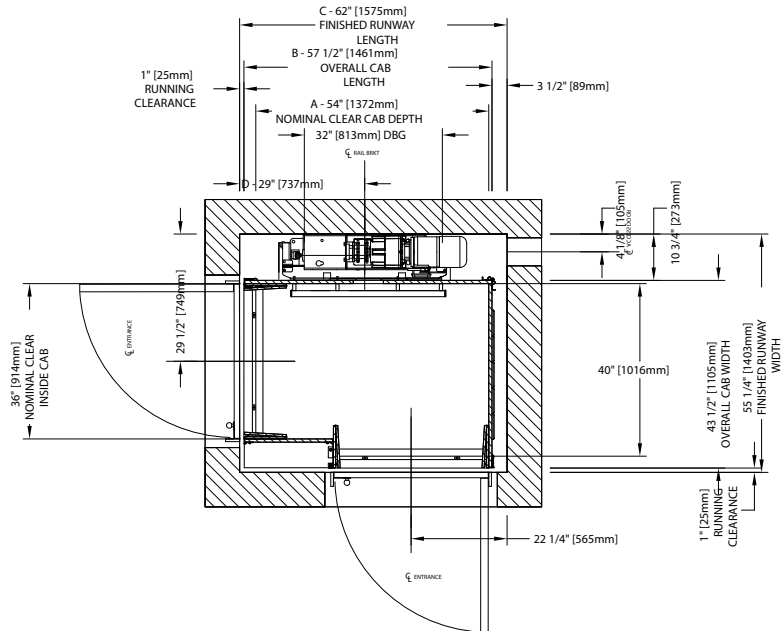

A NOMINAL CLEAR INSIDE CAB LENGTH		B OVERALL CAB LENGTH		C FINISHED RUNWAY LENGTH		D RAIL CENTRE LINE	
mm	inches	mm		mm	inches	mm	inches
1219	48	1308	51 1/2	1422	56	660	26
1372	54	1461	57 1/2	1575	62	737	29
1524	60	1613	63 1/2	1702	67	864	34

Eclipse with auto slim doors (35.5" opening)

Auto slim doors entrance assembly, CO = 2100

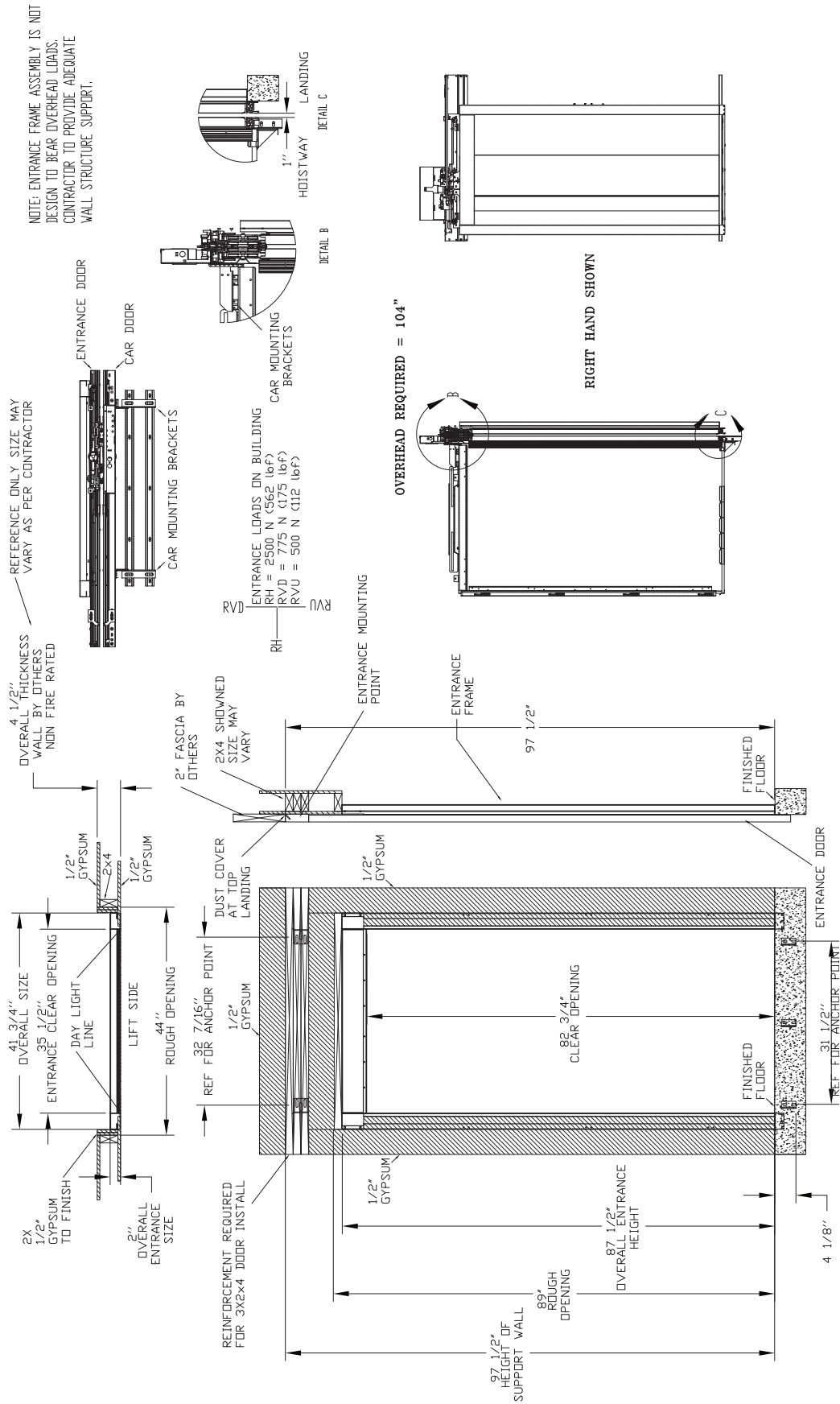

Sample elevation view – auto slim doors (Type 1L shown)

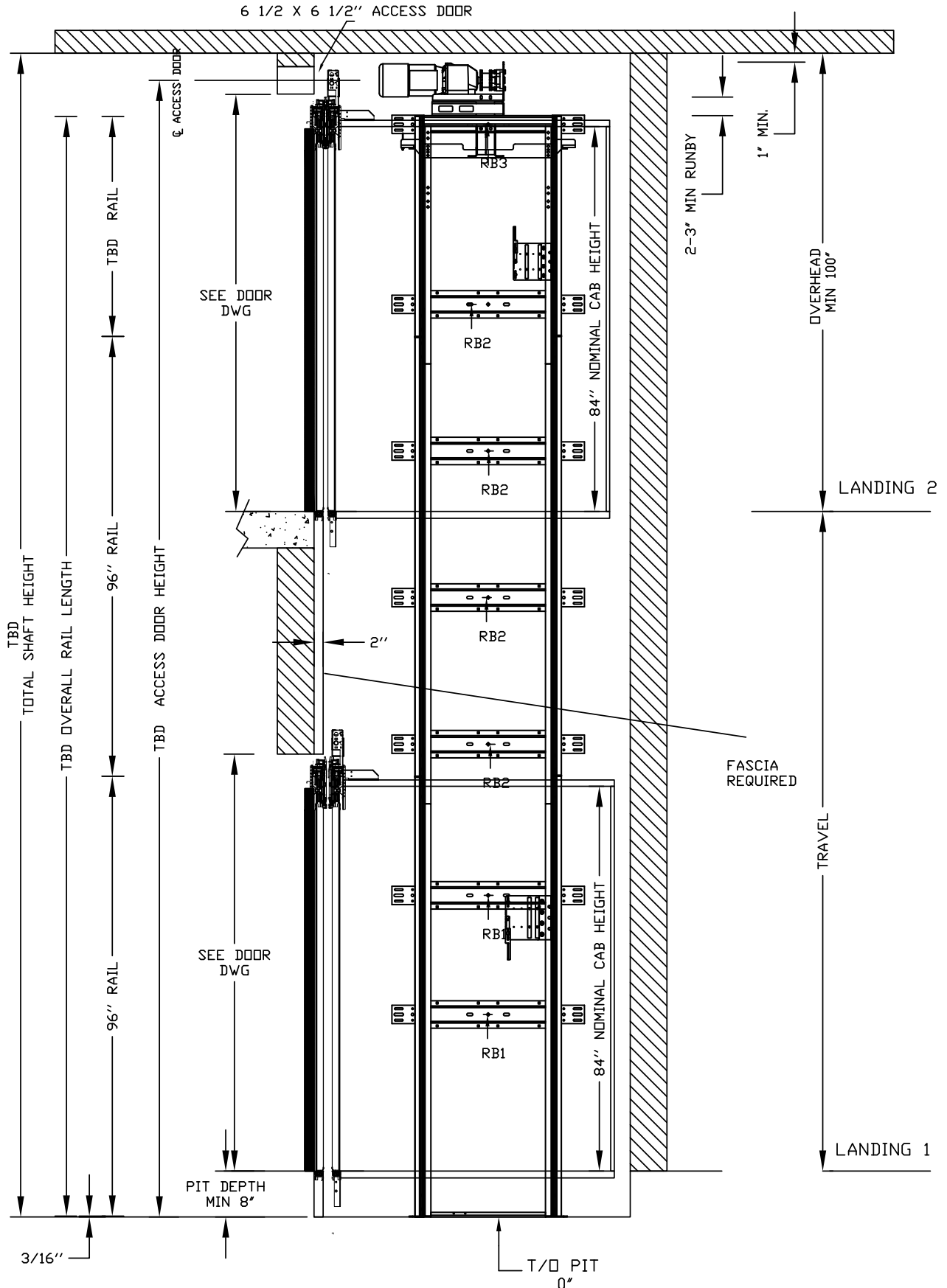

Type 1L (auto slim doors) - 35.5" opening

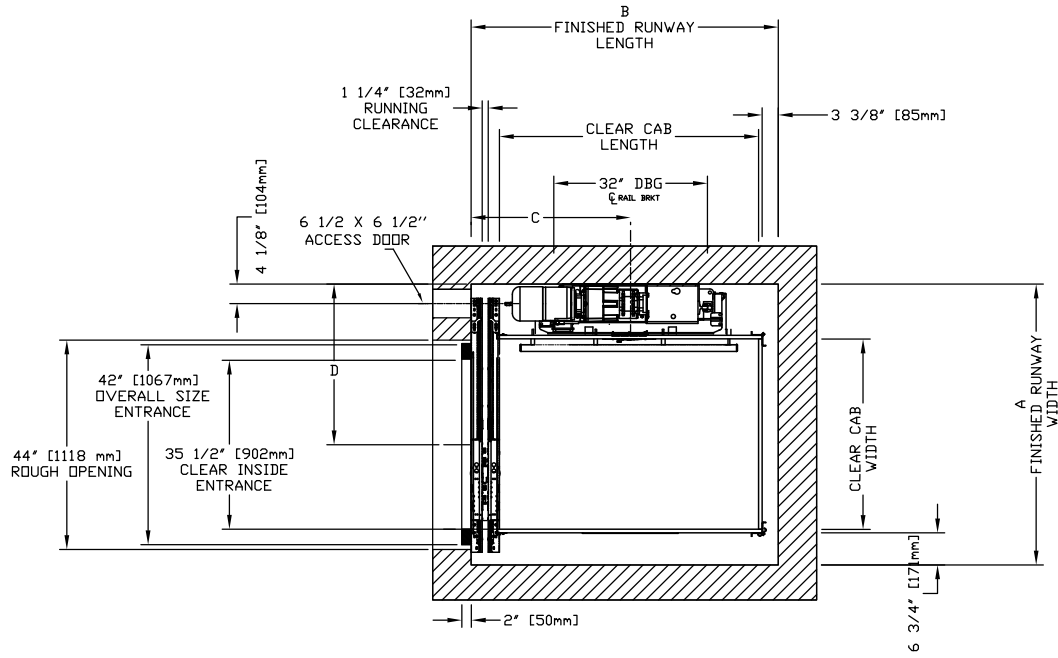

CLEAR INSIDE CAB WIDTH		CLEAR INSIDE CAB LENGTH		A FINISHED RUNWAY WIDTH		B FINISHED RUNWAY LENGTH		C RAIL CENTER LINE		D DOOR CENTER LINE	
mm	Inches	mm	Inches	mm	Inches	mm	Inches	mm	Inches	mm	Inches
914	36	1219	48	1499	59	1473	58	794	31 1/4	838	33
914	36	1372	54	1499	59	1626	64	845	33 1/4	838	33
914	36	1524	60	1499	59	1778	70	921	36 1/4	838	33
1016	40	1372	54	1524	60	1626	64	845	33 1/4	883	34 3/4

Type 1R (auto slim doors) - 35.5" opening

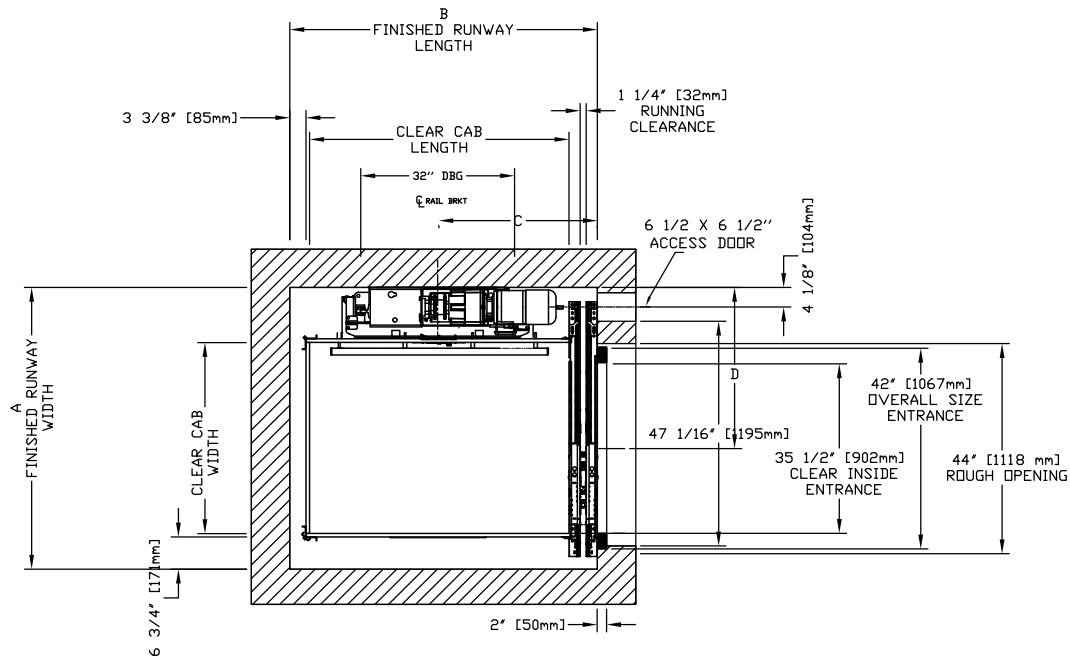

CLEAR INSIDE CAB WIDTH		CLEAR INSIDE CAB LENGTH		A FINISHED RUNWAY WIDTH		B FINISHED RUNWAY LENGTH		C RAIL CENTER LINE		D DOOR CENTER LINE	
mm	Inches	mm	Inches	mm	Inches	mm	Inches	mm	Inches	mm	Inches
914	36	1219	48	1499	59	1473	58	794	31 1/4	838	33
914	36	1372	54	1499	59	1626	64	845	33 1/4	838	33
914	36	1524	60	1499	59	1778	70	921	36 1/4	838	33
1016	40	1372	54	1524	60	1626	64	845	33 1/4	883	34 3/4

Type 2 (auto slim doors) - 35.5" opening

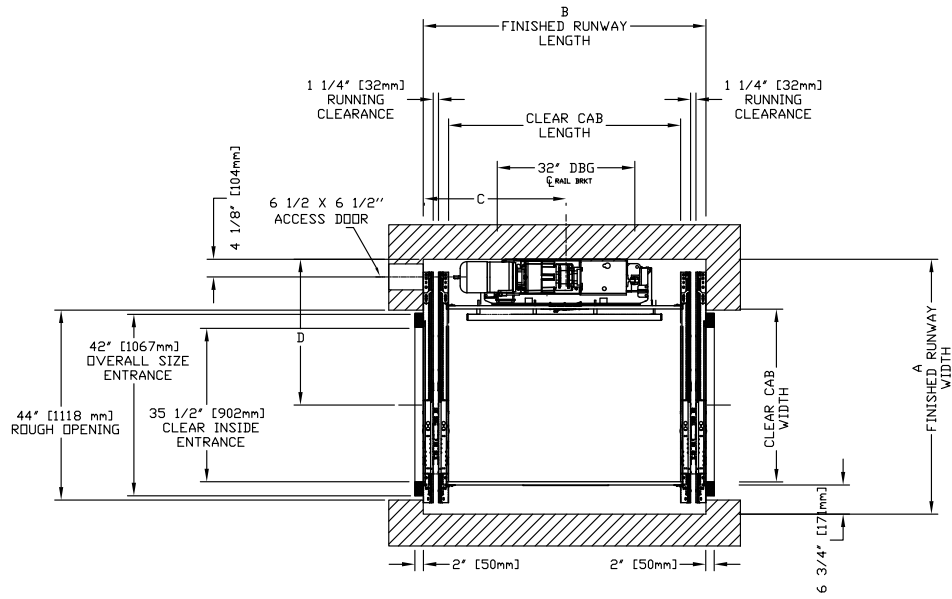

CLEAR INSIDE CAB WIDTH		CLEAR INSIDE CAB LENGTH		A FINISHED RUNWAY WIDTH		B FINISHED RUNWAY LENGTH		C RAIL CENTER LINE		D DOOR CENTER LINE	
mm	Inches	mm	Inches	mm	Inches	mm	Inches	mm	Inches	mm	Inches
914	36	1219	48	1499	59	1518	59 3/4	759	29 7/8	838	33
914	36	1372	54	1499	59	1670	65 3/4	835	32 7/8	838	33
914	36	1524	60	1499	59	1822	71 3/4	911	35 7/8	838	33
1016	40	1372	54	1524	60	1670	65 3/4	835	32 7/8	883	34 3/4

Type 3 (auto slim doors) - 35.5" opening

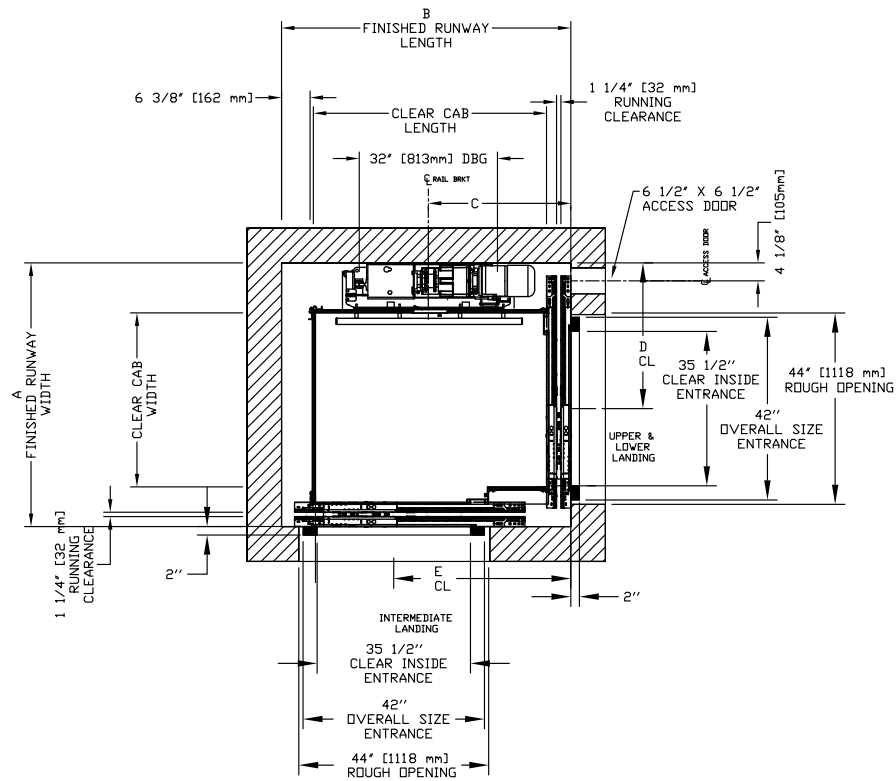

CLEAR INSIDE CAB WIDTH		CLEAR INSIDE CAB LENGTH		A FINISHED RUNWAY WIDTH		B FINISHED RUNWAY LENGTH		C RAIL CENTER LINE		D DOOR CENTER LINE		E DOOR CENTER LINE	
mm	Inches	mm	Inches	mm	Inches	mm	Inches	mm	Inches	mm	Inches	mm	Inches
914	36	1372	54	1540	60 5/8	1702	67	838	33	838	33	1064	41 7/8
914	36	1524	60	1540	60 5/8	1854	73	914	36	838	33	1216	47 7/8
1016	40	1372	54	1581	62 1/4	1702	67	838	33	883	34 3/4	1064	41 7/8

Type 4 (auto slim doors) - 35.5" opening

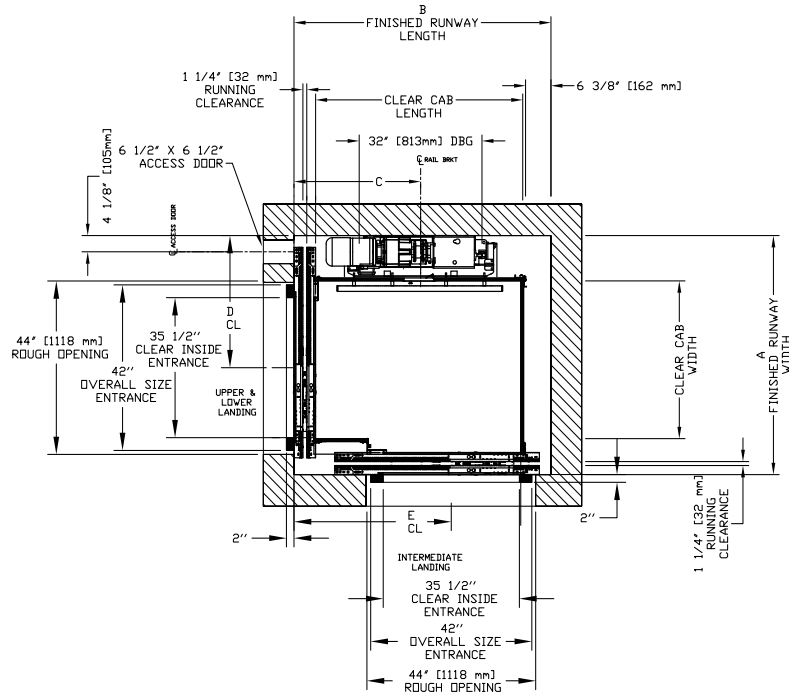

CLEAR INSIDE CAB WIDTH		CLEAR INSIDE CAB LENGTH		A FINISHED RUNWAY WIDTH		B FINISHED RUNWAY LENGTH		C RAIL CENTER LINE		D DOOR CENTER LINE		E DOOR CENTER LINE	
mm	Inches	mm	Inches	mm	Inches	mm	Inches	mm	Inches	mm	Inches	mm	Inches
914	36	1372	54	1540	60 5/8	1702	67	838	33	838	33	1064	41 7/8
914	36	1524	60	1540	60 5/8	1854	73	914	36	838	33	1216	47 7/8
1016	40	1372	54	1581	62 1/4	1702	67	838	33	883	34 3/4	1064	41 7/8

Type 5 (auto slim doors) - 35.5" opening

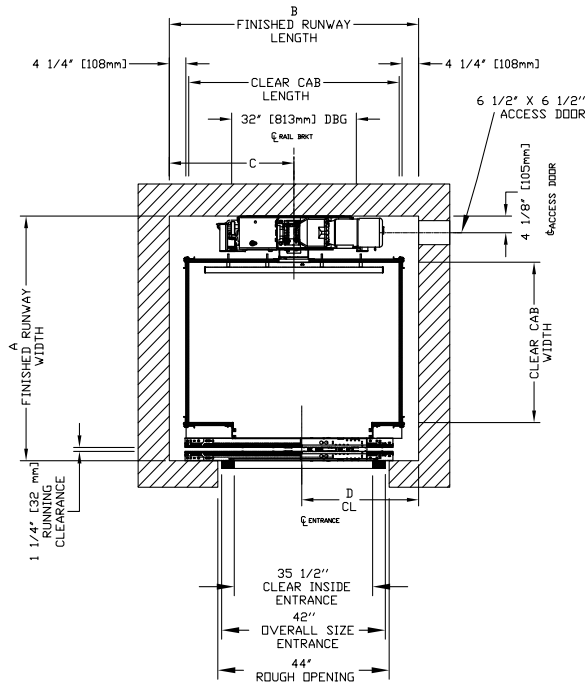

CLEAR INSIDE CAB WIDTH		CLEAR INSIDE CAB LENGTH		A FINISHED RUNWAY WIDTH		B FINISHED RUNWAY LENGTH		C RAIL CENTER LINE		D DOOR CENTER LINE	
mm	Inches	mm	Inches	mm	Inches	mm	Inches	mm	Inches	mm	Inches
914	36	1372	54	1486	58 1/2	1626	64	813	32	762	30
914	36	1524	60	1486	58 1/2	1778	70	889	35	762	30
1016	40	1372	54	1588	62 1/2	1626	64	813	32	762	30

Eclipse with auto slim doors 29.5" opening

Type 1L (auto slim doors on car and landing) - 29.5" opening

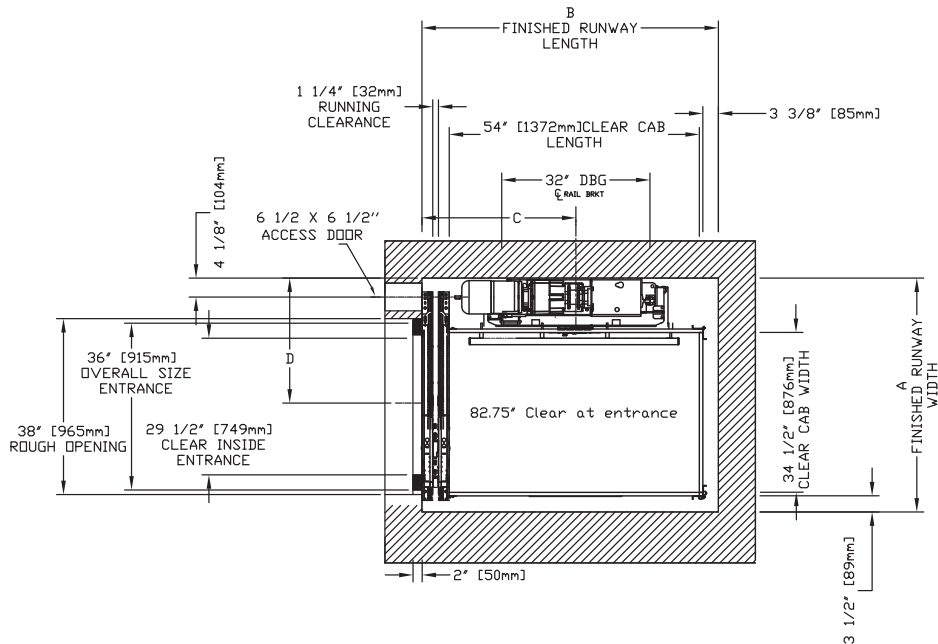

CLEAR INSIDE CAB WIDTH		CLEAR INSIDE CAB LENGTH		A FINISHED RUNWAY WIDTH		B FINISHED RUNWAY LENGTH		C RAIL CENTER LINE		D DOOR CENTER LINE	
mm	Inches	mm	Inches	mm	Inches	mm	Inches	mm	Inches	mm	Inches
876	34 1/2	1219	48	1283	50 1/2	1473	58	794	31 1/4	686	27
876	34 1/2	1372	54	1283	50 1/2	1626	64	845	33 1/4	686	27
876	34 1/2	1524	60	1283	50 1/2	1778	70	921	36 1/4	686	27

Type 1L (auto slim doors on car, swing doors on landing) - 29.5" opening

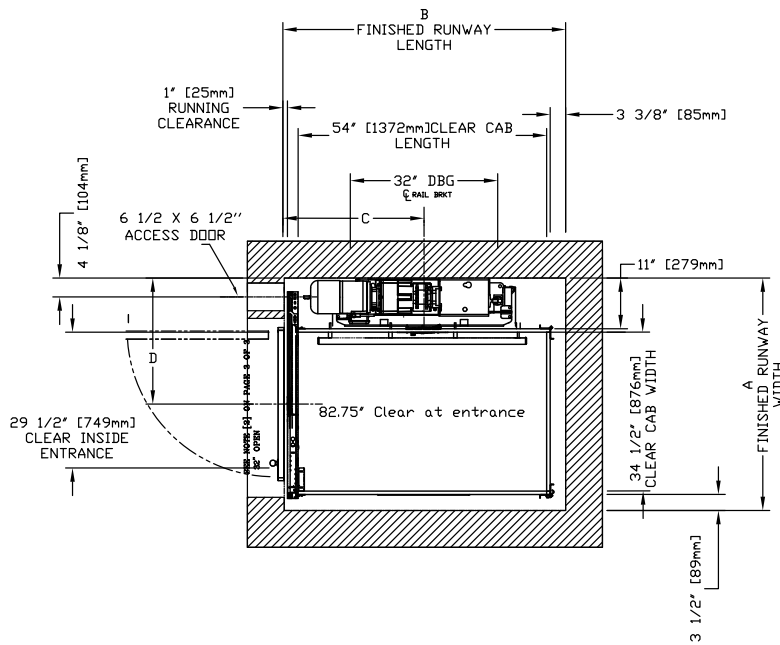

CLEAR INSIDE CAB WIDTH		CLEAR INSIDE CAB LENGTH		A FINISHED RUNWAY WIDTH		B FINISHED RUNWAY LENGTH		C RAIL CENTER LINE		D DOOR CENTER LINE	
mm	Inches	mm	Inches	mm	Inches	mm	Inches	mm	Inches	mm	Inches
876	34 1/2	1219	48	1283	50 1/2	1408	55 7/16	729	28 11/16	695	27 3/8
876	34 1/2	1372	54	1283	50 1/2	1561	61 7/16	779	30 11/16	695	27 3/8
876	34 1/2	1524	60	1283	50 1/2	1713	67 7/16	856	33 11/16	695	27 3/8

Type 1R (auto slim doors on car and landing) - 29.5" opening

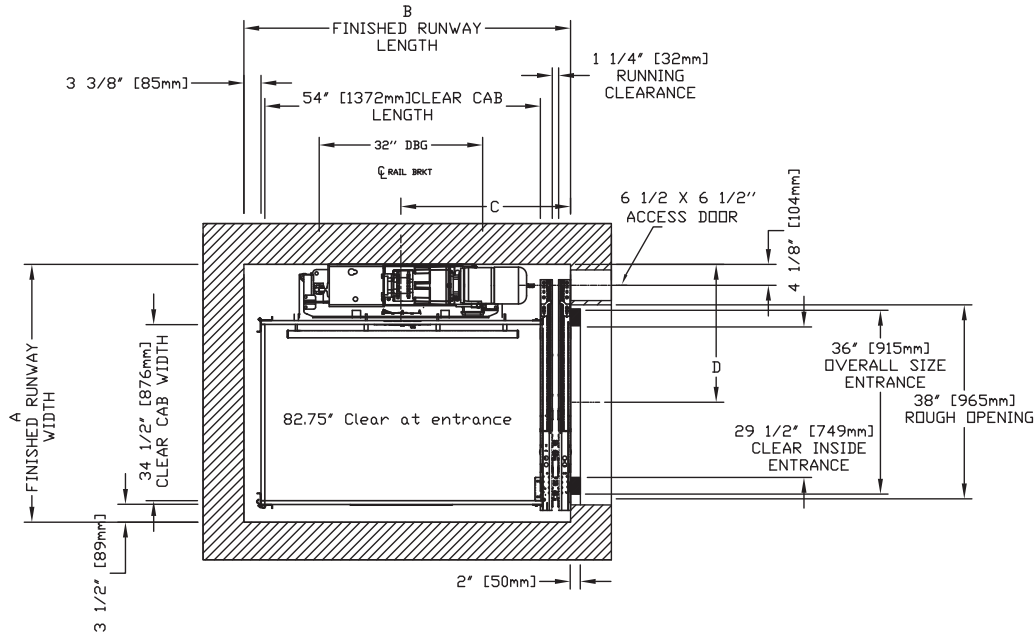

CLEAR INSIDE CAB WIDTH		CLEAR INSIDE CAB LENGTH		A FINISHED RUNWAY WIDTH		B FINISHED RUNWAY LENGTH		C RAIL CENTER LINE		D DOOR CENTER LINE	
mm	Inches	mm	Inches	mm	Inches	mm	Inches	mm	Inches	mm	Inches
876	34 1/2	1219	48	1283	50 1/2	1473	58	794	31 1/4	686	27
876	34 1/2	1372	54	1283	50 1/2	1626	64	845	33 1/4	686	27
876	34 1/2	1524	60	1283	50 1/2	1778	70	921	36 1/4	686	27

Type 1R (auto slim doors on car, swing doors on landing) - 29.5" opening

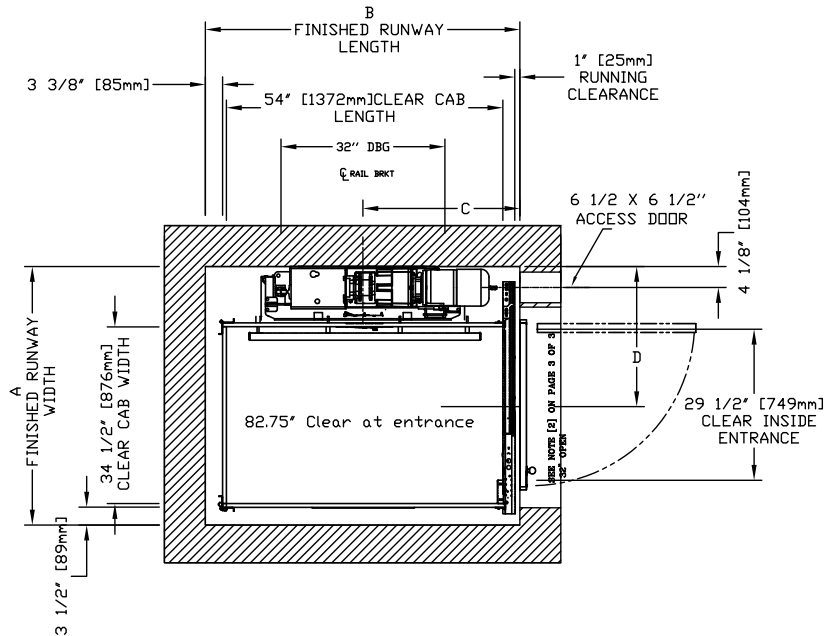

CLEAR INSIDE CAB WIDTH		CLEAR INSIDE CAB LENGTH		A FINISHED RUNWAY WIDTH		B FINISHED RUNWAY LENGTH		C RAIL CENTER LINE		D DOOR CENTER LINE	
mm	Inches	mm	Inches	mm	Inches	mm	Inches	mm	Inches	mm	Inches
876	34 1/2	1219	48	1283	50 1/2	1408	55 7/16	729	28 11/16	695	27 3/8
876	34 1/2	1372	54	1283	50 1/2	1561	61 7/16	779	30 11/16	695	27 3/8
876	34 1/2	1524	60	1283	50 1/2	1713	67 7/16	856	33 11/16	695	27 3/8

Type 2 (auto slim doors on car and landing) - 29.5" opening

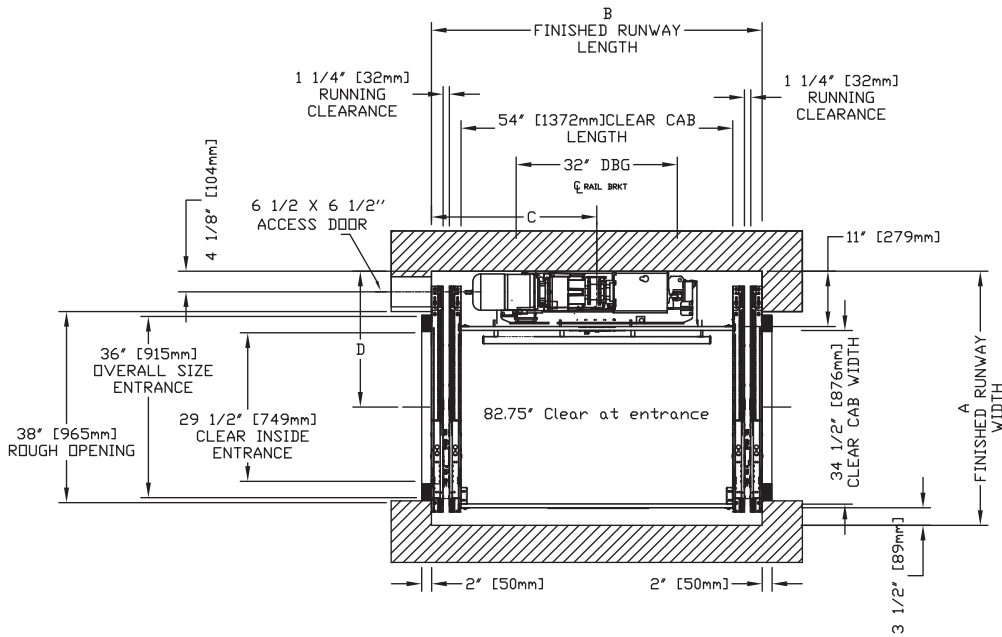

CLEAR INSIDE CAB WIDTH		CLEAR INSIDE CAB LENGTH		A FINISHED RUNWAY WIDTH		B FINISHED RUNWAY LENGTH		C RAIL CENTER LINE		D DOOR CENTER LINE	
mm	Inches	mm	Inches	mm	Inches	mm	Inches	mm	Inches	mm	Inches
876	34 1/2	1219	48	1283	50 1/2	1518	59 3/4	759	29 7/8	686	27
876	34 1/2	1372	54	1283	50 1/2	1670	65 3/4	835	32 7/8	686	27
876	34 1/2	1524	60	1283	50 1/2	1822	71 3/4	911	35 7/8	686	27

Type 2 (auto slim doors on car, swing doors on landing) - 29.5" opening

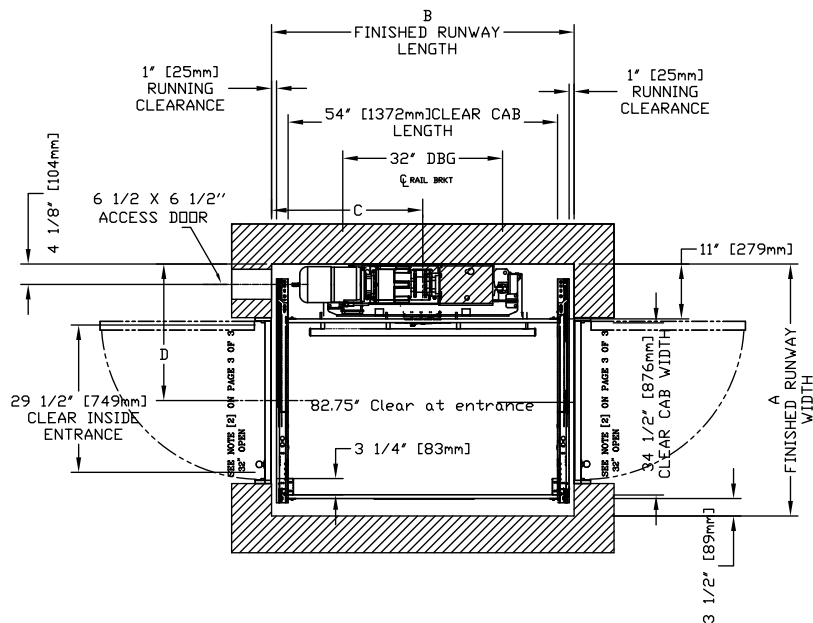

CLEAR INSIDE CAB WIDTH		CLEAR INSIDE CAB LENGTH		A FINISHED RUNWAY WIDTH		B FINISHED RUNWAY LENGTH		C RAIL CENTER LINE		D DOOR CENTER LINE	
mm	Inches	mm	Inches	mm	Inches	mm	Inches	mm	Inches	mm	Inches
876	34 1/2	1219	48	1283	50 1/2	1387	54 5/8	694	27 5/16	695	27 3/8
876	34 1/2	1372	54	1283	50 1/2	1540	60 5/8	770	30 5/16	695	27 3/8
876	34 1/2	1524	60	1283	50 1/2	1692	66 5/8	846	33 5/16	695	27 3/8

Type 3 with auto slim doors on car and landing (29.5" opening)

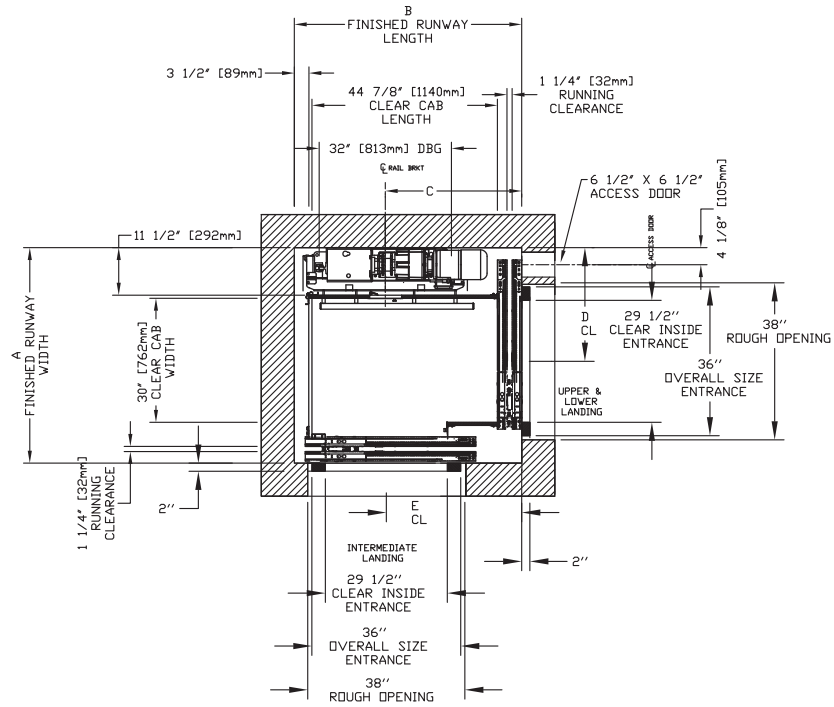

CLEAR INSIDE CAB WIDTH		CLEAR INSIDE CAB LENGTH		A FINISHED RUNWAY WIDTH		B FINISHED RUNWAY LENGTH		C RAIL CENTER LINE		D DOOR CENTER LINE		E DOOR CENTER LINE	
mm	Inches	mm	Inches	mm	Inches	mm	Inches	mm	Inches	mm	Inches	mm	Inches
762	30	1140	44 7/8	1324	52 1/8	1397	55	838	33	699	27 1/2	832	32 3/4
762	30	1292	50 7/8	1324	52 1/8	1549	61	838	33	699	27 1/2	984	38 3/4
762	30	1445	56 7/8	1324	52 1/8	1702	67	914	36	699	27 1/2	1137	44 3/4

Type 3 with auto slim doors on car, swing doors on landing (29.5" opening)

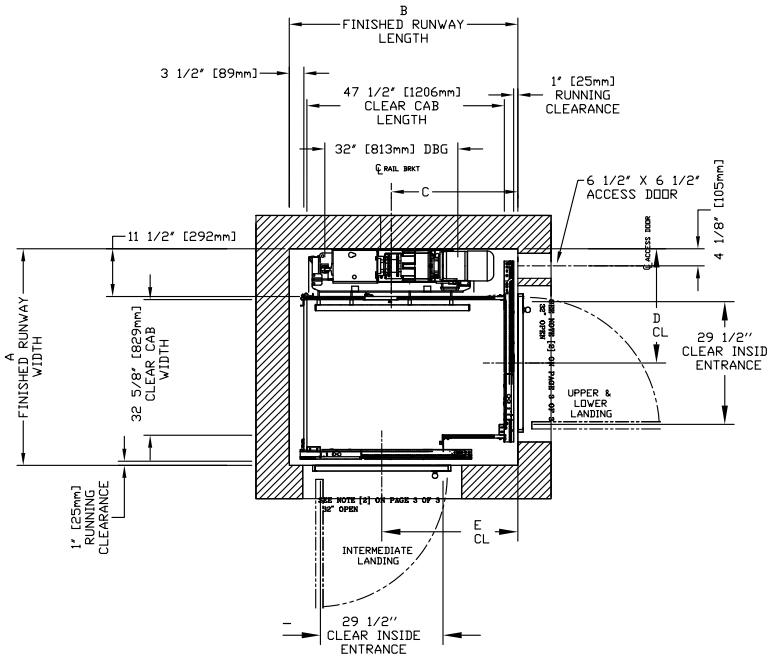

CLEAR INSIDE CAB WIDTH		CLEAR INSIDE CAB LENGTH		A FINISHED RUNWAY WIDTH		B FINISHED RUNWAY LENGTH		C RAIL CENTER LINE		D DOOR CENTER LINE		E DOOR CENTER LINE	
mm	Inches	mm	Inches	mm	Inches	mm	Inches	mm	Inches	mm	Inches	mm	Inches
829	32 5/8	1207	47 1/2	1324	52 1/8	1397	55	762	30	699	27 1/2	832	32 3/4
829	32 5/8	1359	53 1/2	1324	52 1/8	1549	61	838	33	699	27 1/2	984	38 3/4
829	32 5/8	1511	59 1/2	1324	52 1/8	1702	67	914	36	699	27 1/2	1137	44 3/4

Eclipse hoistway with rail

Hoistway type 1 right hand with rail

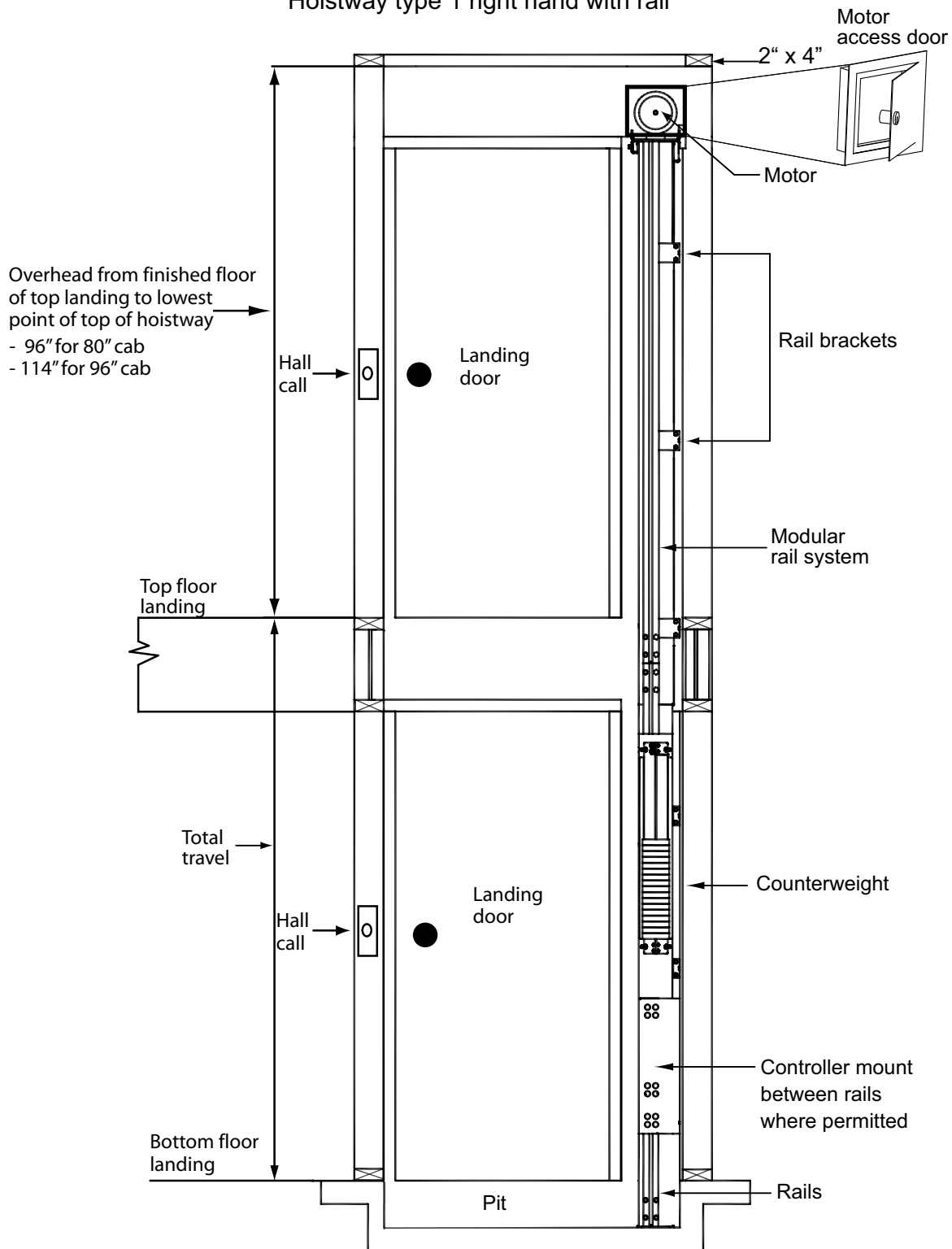

Eclipse hoistway mount

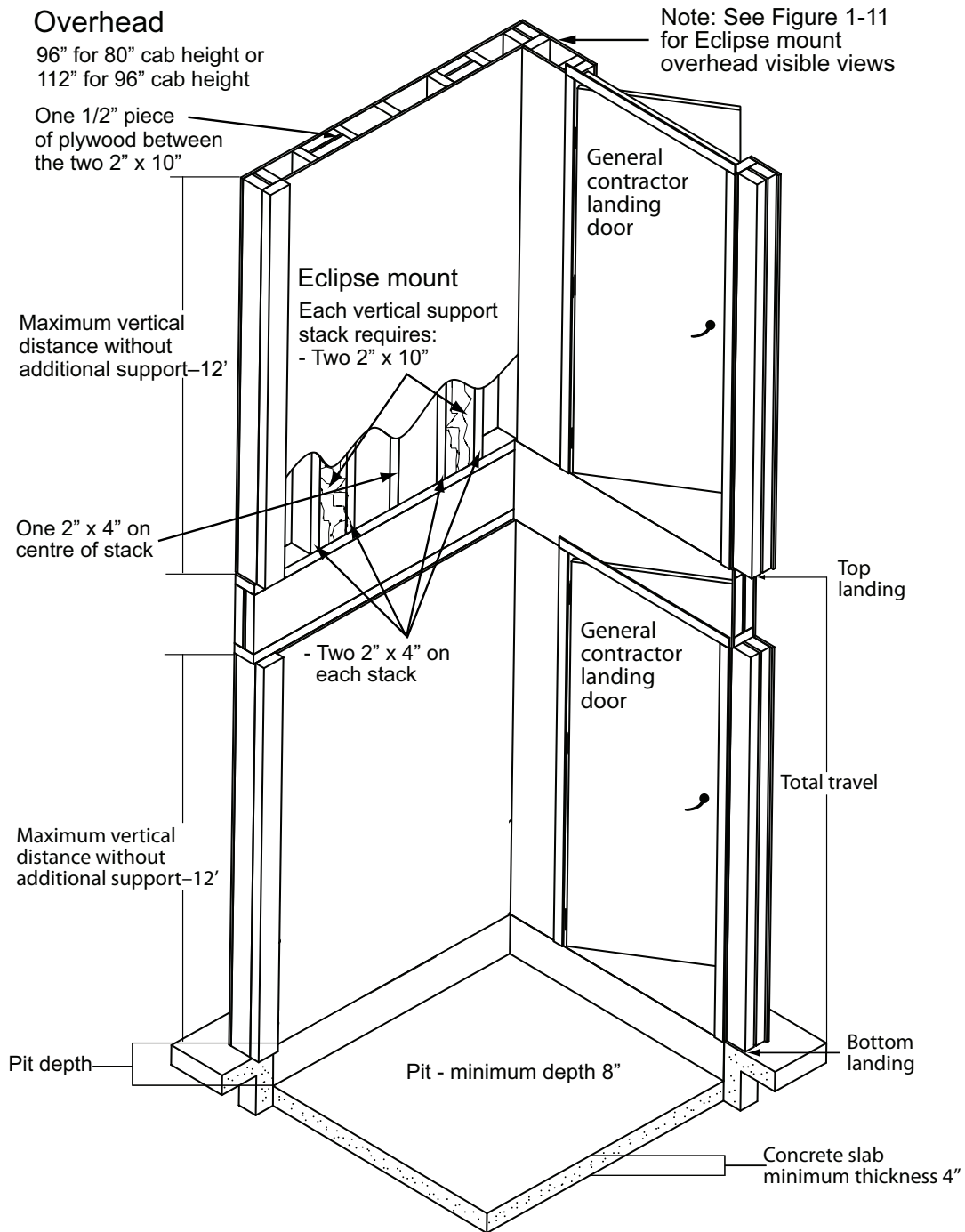

⚠ WARNING

Pipes conveying steam, gas or liquids, which, if discharged into the hoistway would endanger life, shall not be installed in the hoistway.

Eclipse top of hoistway view for wood construction

Structural views for elevator

Overhead view of Eclipse support wall

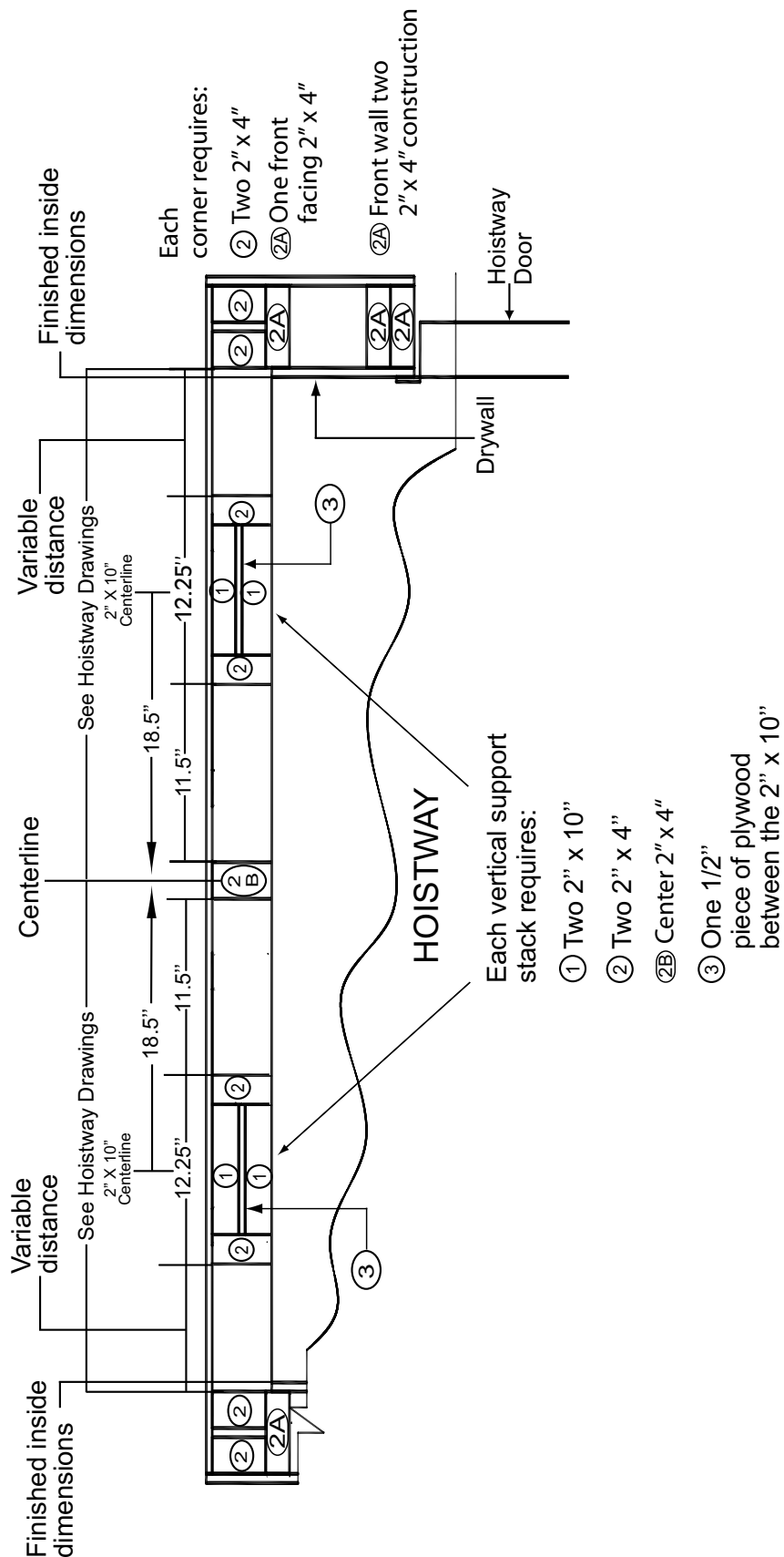

Wall configuration for wood construction (continued)

Structural views for elevator shaft (continued)

Front view of support wall

Eclipse mount load bearing wall
Top of hoistway

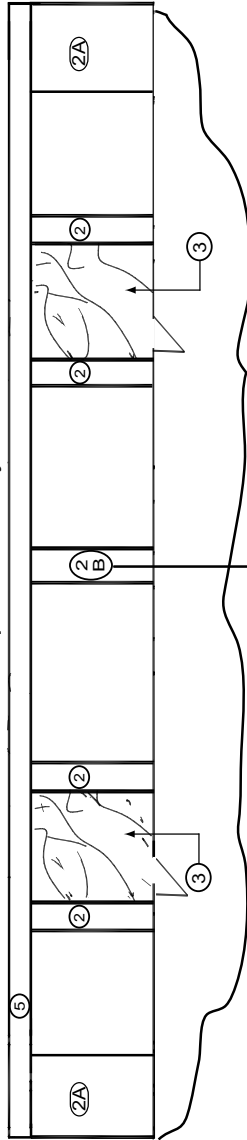

Ensure front wall of shaft uses 2" x 4" construction to avoid 3/4" & 4" code violation based on 3/4" & 4" rule. See 3/4" & 4" rule in this guide.

Eclipse mount front wall view

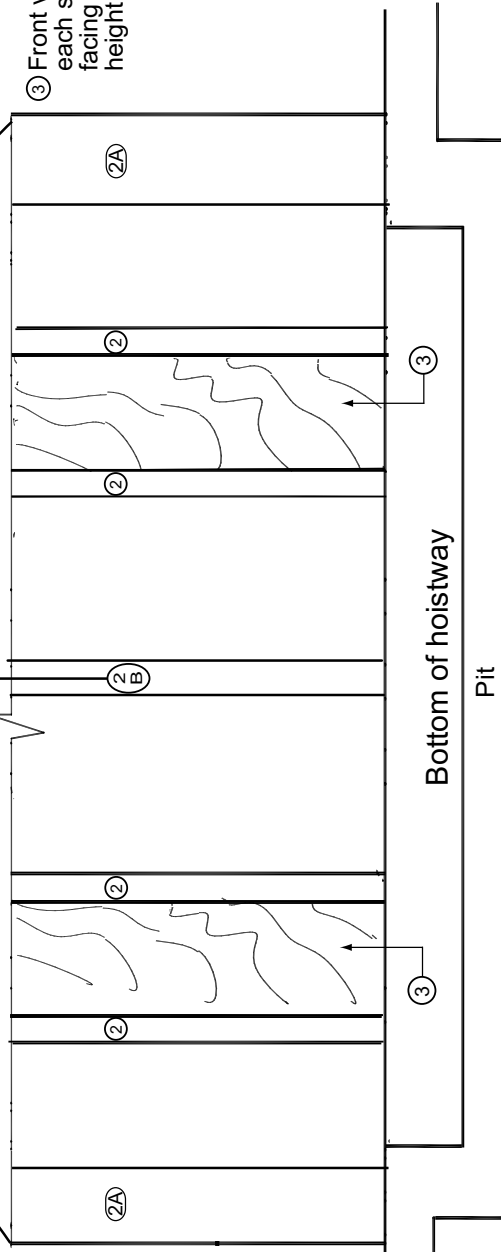

- ② Showing both vertical stacks with all four 2" x 4" vertical stacks
- ②A Showing front facing 2" x 4"
- ②B Center 2" x 4"

③ Front view shows each stack's front facing 2" x 4" height of hoistway

Loads on building and forces on rails

RAIL FORCES		
* R1	* R2	PRODUCT
422 lbf.	251 lbf.	Eclipse HD
304 lbf.	194 lbf.	Eclipse
RAIL WEIGHT 8.0 lbs / ft		

R3 NOTE:	
PIT FLOOR TO SUPPORT LOAD OF:	
* (INCLUDES IMPACT)	
PRODUCT	
8.22 Kips	Eclipse HD
5.6 Kips	Eclipse

FOR TOTAL PULL-OUT FORCE ON RAIL BRACKET, R1 MUST BE DOUBLED eg. 608 lbf for Eclipse

R1: Equal and opposing reaction loads caused by offset suspension means relative to center of mass-top shoes pull out; bottom shoes push in.

R2: Side forces experienced on rail face caused by asymmetrical loading.

R3: Downforce on the rail under safety stop conditions.

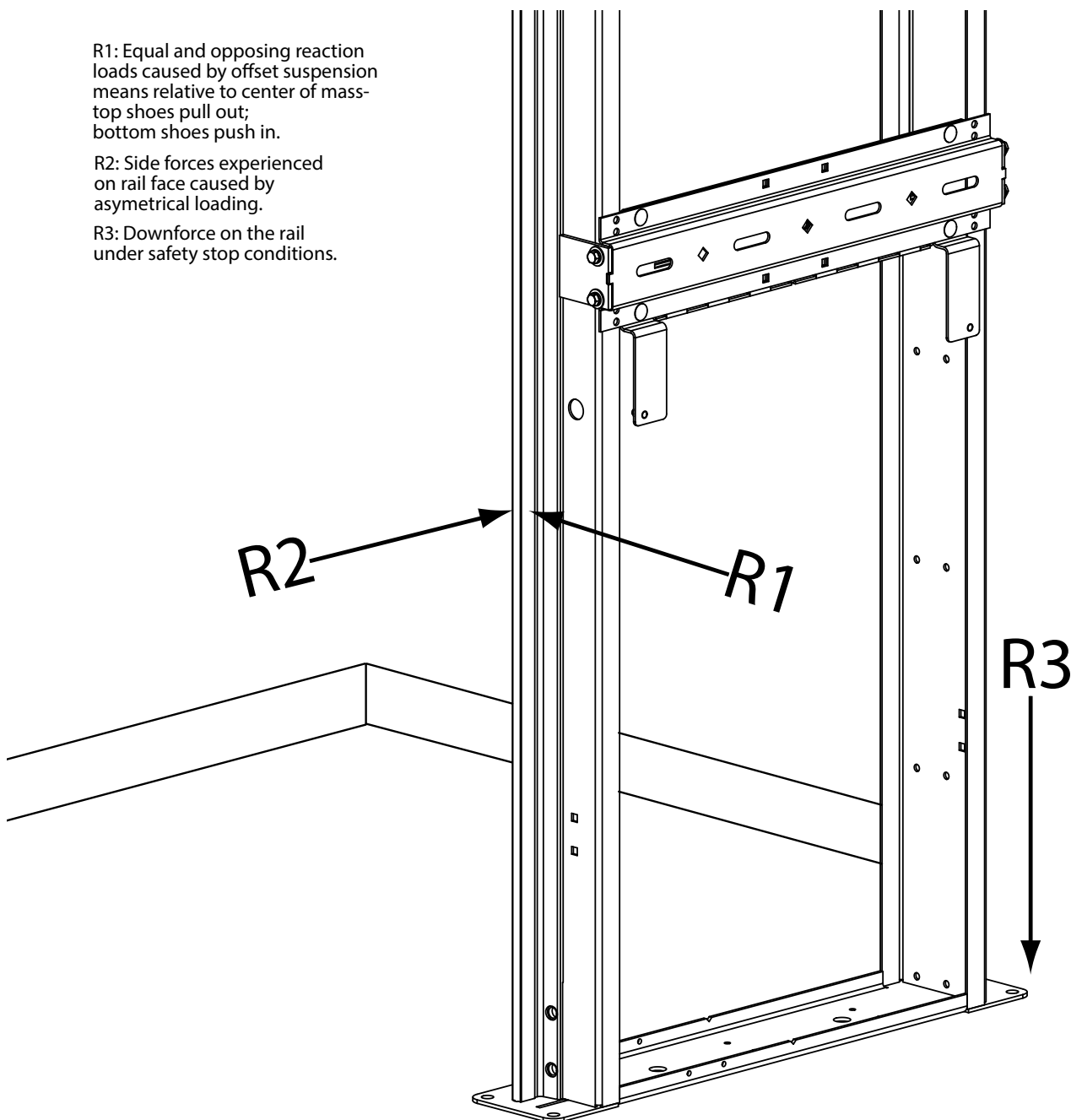

Eclipse electrical requirements

By General Contractor/Owner

Your electrician and phone installer supply the following connections:

- Main disconnect - One (1) 230V single-phase 30 Amp fused disconnect (if voltage is not 230V minimum, a buck-boost transformer is required)
- Lighting disconnect - One (1) 120V 15 Amp fused disconnect or circuit breaker for cab lighting
- Telephone line - One (1) telephone line jack in close proximity to the controller

NOTE: Savaria Corporation does not provide power cable to main disconnect.

Recommended manufacturers for fused disconnect

Square D

- Main disconnect: 230V single-phase disconnect model # H221N
- 240V - 30 Amp with Interlock Kit - ELK031 Aux Contacts (normally opened/normally closed)
- In addition, two each - 250V, 20 Amp, RK5 fuses
- Lighting disconnect: 120V 15 Amp fused disconnect or circuit breaker

Siemens

- Main disconnect: 230V single-phase disconnect model #HF221N
- 240V - 30 Amp with Interlock Kit-HA 161234 Aux Contacts (normally opened/normally closed)
- In addition, two each - 250V, 20 Amp, RK5 fuses
- Lighting disconnect: 120V 15 Amp fused disconnect or circuit breaker

G.E.

- Main disconnect: 230V single-phase disconnect model # TH3221
- 240V - 30 Amp with Interlock Kit - THAUX21D Aux Contacts (normally opened/normally closed)
- In addition, two each - 250V, 20 Amp, RK5 fuses
- Lighting disconnect - 120V 15 Amp fused disconnect or circuit breaker

Cutler Hammer

- Main disconnect: 230V single-phase disconnect model # DH221NGK
- 240V - 30 Amp with Interlock Kit - THAUX21D Aux Contacts (normally opened/normally closed)
- In addition, two each - 250V, 20 Amp, RK5 fuses
- Lighting disconnect: 120V 15 Amp fused disconnect or circuit breaker

Recommended manufacturers for circuit breakers at the distribution panel (and the distribution panel itself): Square D or Siemens only.

Wiring (use as reference)

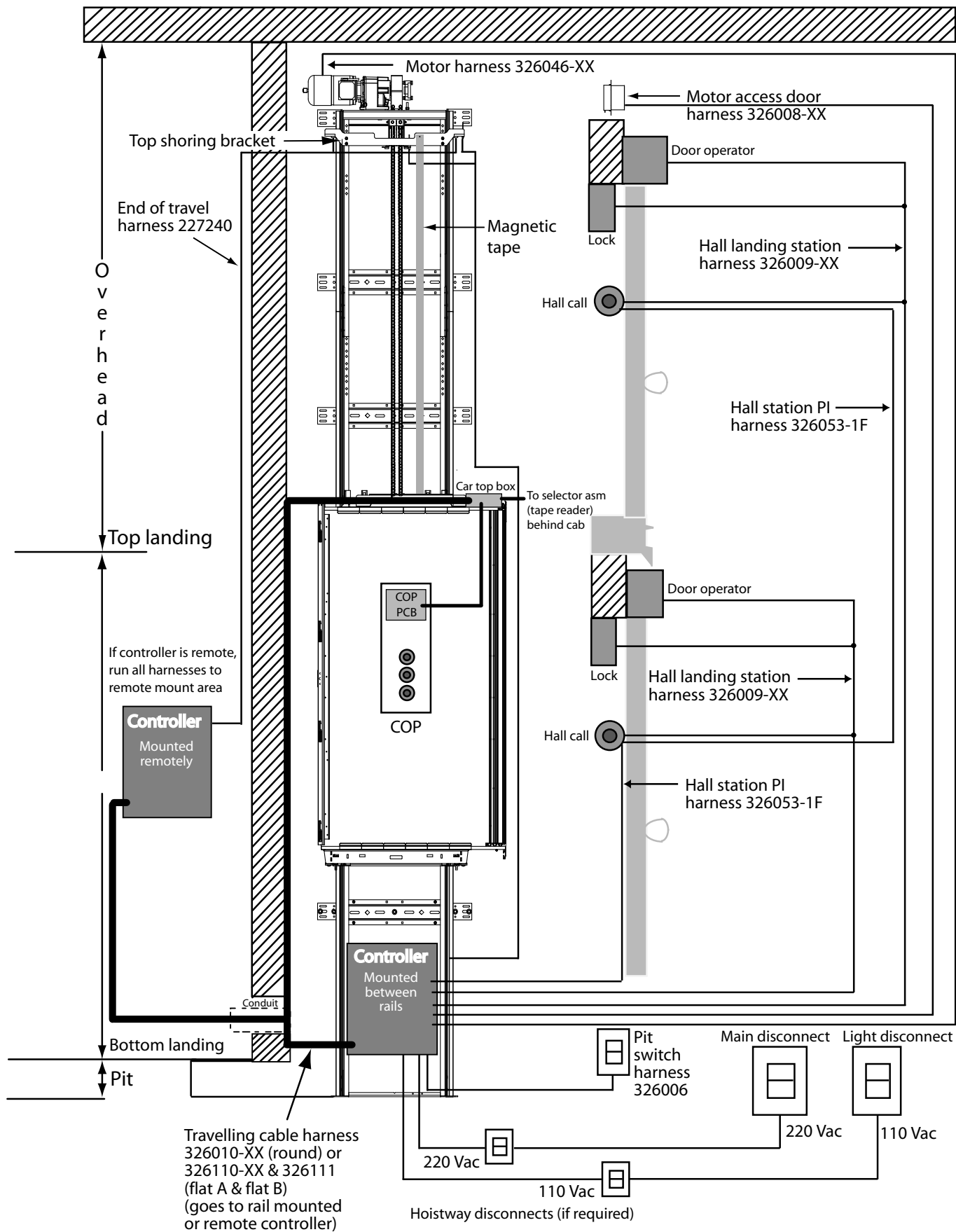

Controller box dimensions

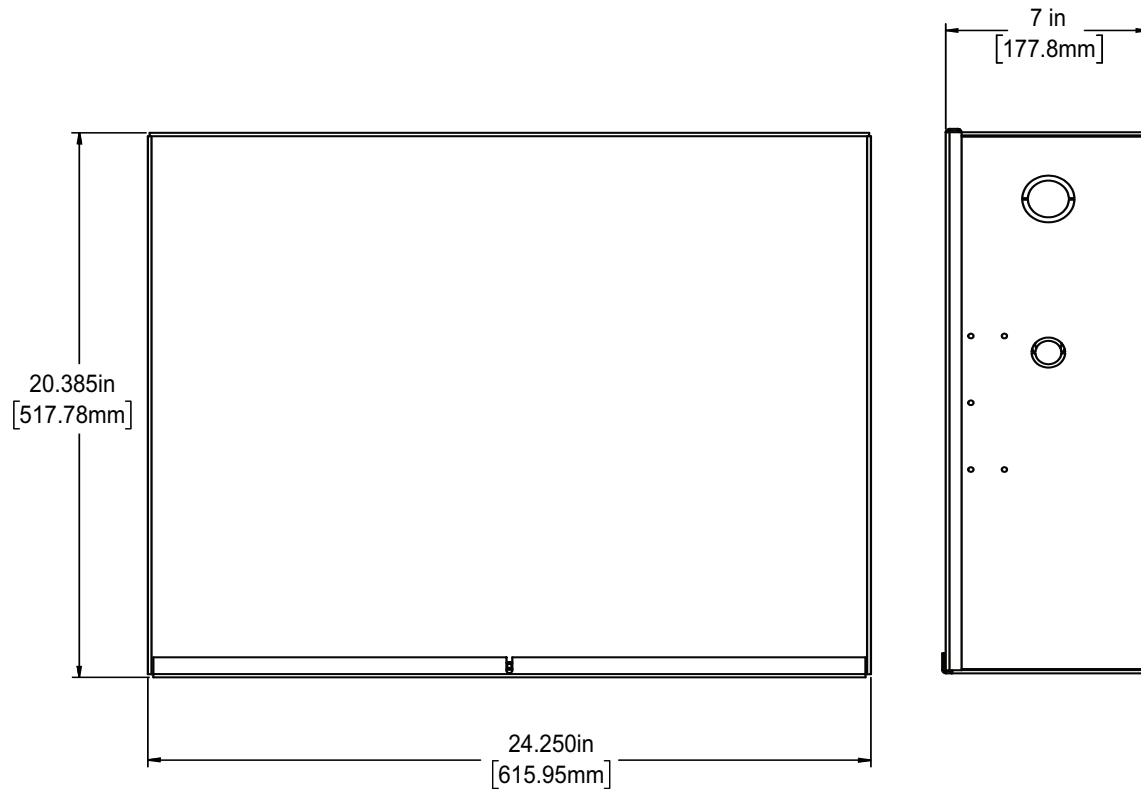

Provisions by others

Savaria Link option

If you have the Savaria Link Ethernet remote monitoring option, ensure that you have an Ethernet connection with Internet capability in the vicinity of the unit's controller.

If you have the Savaria Link Wireless remote monitoring option, ensure that you have a wireless signal with Internet capability in the vicinity of the unit's controller.

Flush wood door instructions for contractors

METHOD TO BUILD FLUSH DOOR: USING STOPPER ON INSIDE OF DOOR FRAME



HOISTWAY VIEW WITH 1/8" SHEET-METAL STOPPER

WARNING : Lock cut-out in top corner representative of a standard 80" door. For taller doors, such as 84" to 96" the top of the cut-out itself needs to stay at 80" from the ground to allow users access to unlock in case of emergency.

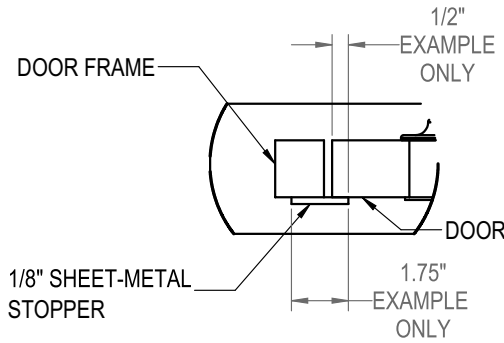
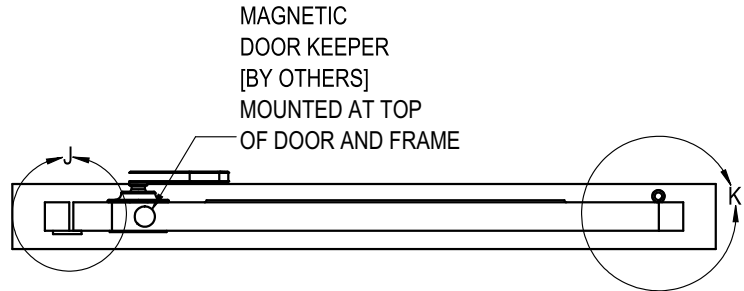

DETAIL J

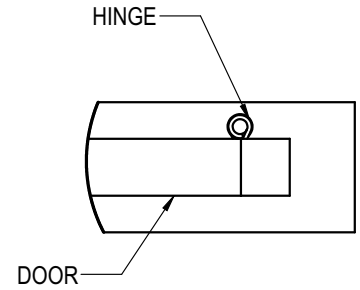

DETAIL K

3X HINGES (SPRING HINGES OR DOOR CLOSER ON HYDRAULIC ELEVATOR AND VPL UNITS)

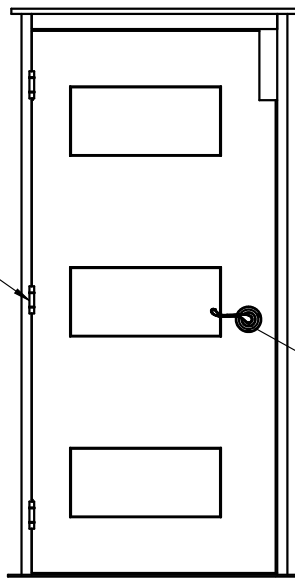

LANDING VIEW

SHEET-METAL STOPPER FLUSH TO DOOR LOCK CUT-OUT
 2-3/8"
 DOOR LOCK CUT-OUT ON DOOR
 10-1/4"

CUP STYLE DOOR HANDLE [BY OTHERS] FROM HOISTWAY VIEW MUST BE FLUSH / RECESSED

NON-FUNCTIONAL DOOR HANDLE [BY OTHERS] FROM LANDING VIEW

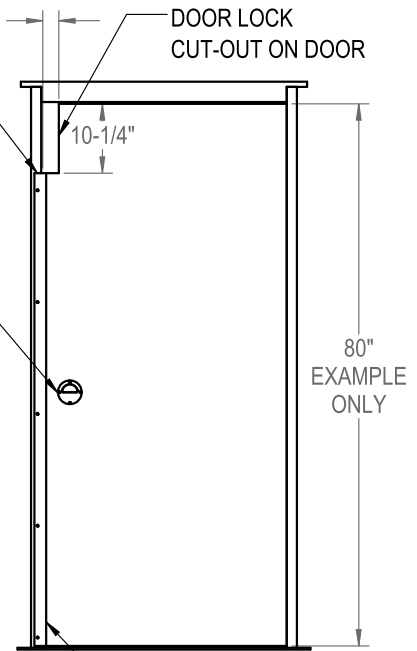

1/8" SHEET-METAL STOPPER HOISTWAY VIEW

Flush wood door instructions for contractors (cont.)

METHOD TO BUILD FLUSH DOOR USING ANGLE (L) BRACKET STOPPER

WARNING: Lock cut-out in top corner representative of a standard 80" door. For taller doors, such as 84" to 96", the top of the cut-out itself needs to stay at 80" from the ground to allow users access to unlock in case of emergency.



HOUSE VIEW WITH "L" BRACKET STOPPER

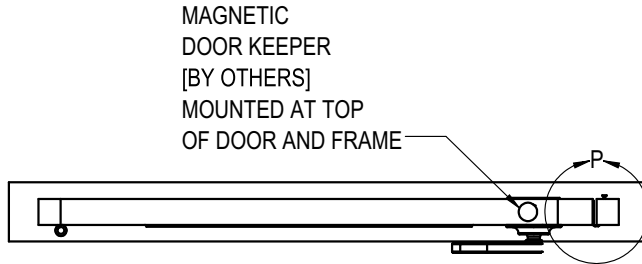

MAGNETIC DOOR KEEPER [BY OTHERS] MOUNTED AT TOP OF DOOR AND FRAME

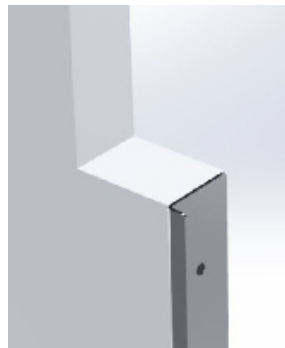

DETAIL M "L" BRACKET MOUNTED ON DOOR SLAB

"L" BRACKET [BY OTHERS]

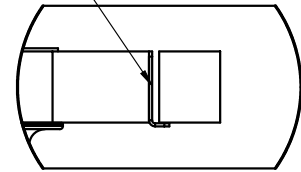

DETAIL P SCALE 1 : 4

CUP STYLE DOOR HANDLE [BY OTHERS] FROM HOISTWAY VIEW MUST BE FLUSH / RECESSED

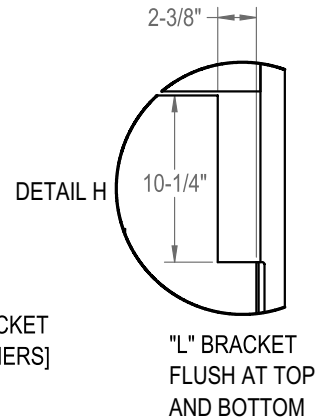
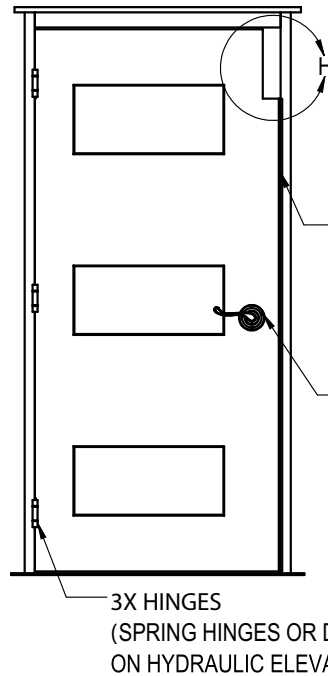
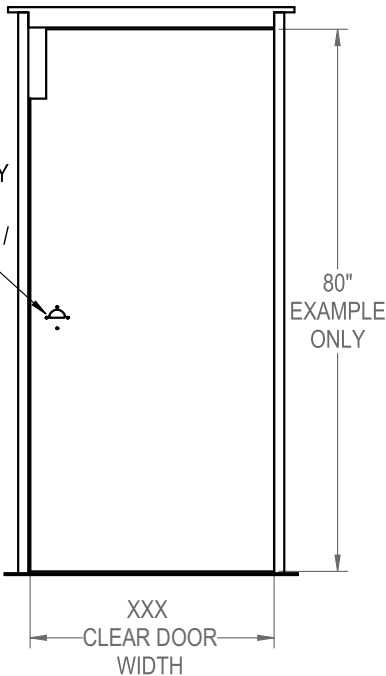

Flush wood door instructions for contractors (cont.)

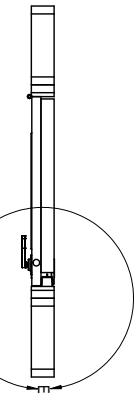
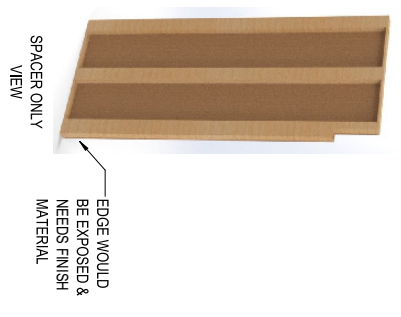
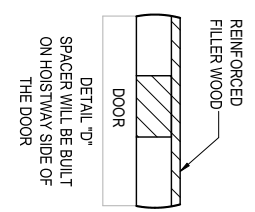
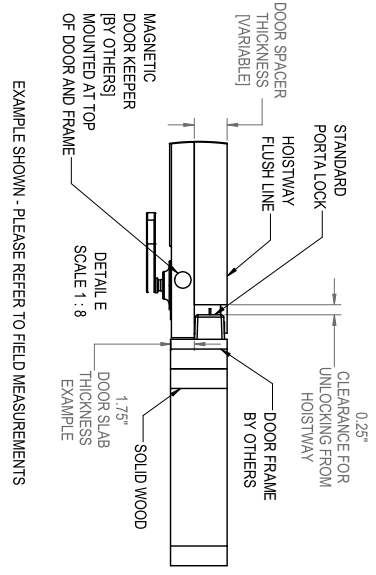

WARNING: Lock cut-out in top corner representative of a standard 80" door. For taller doors, such as 84" to 96", the top of the cut-out itself needs to stay at 90" from the ground to allow users access to unlock in case of emergency.

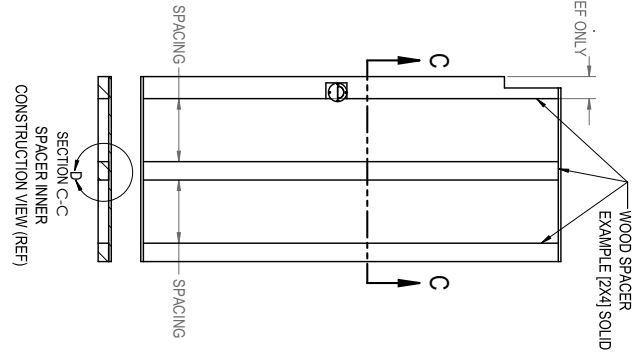
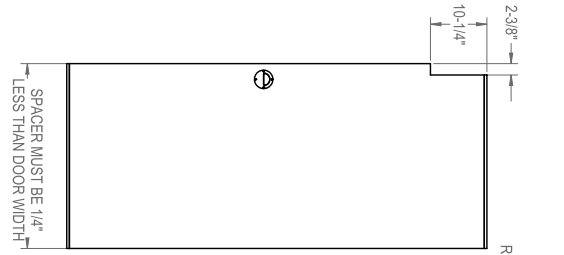
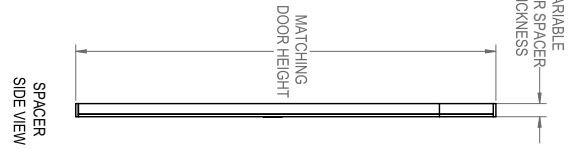
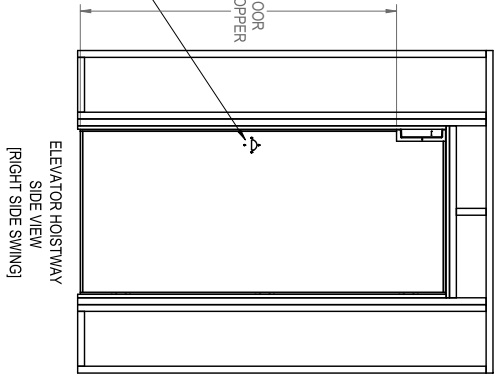
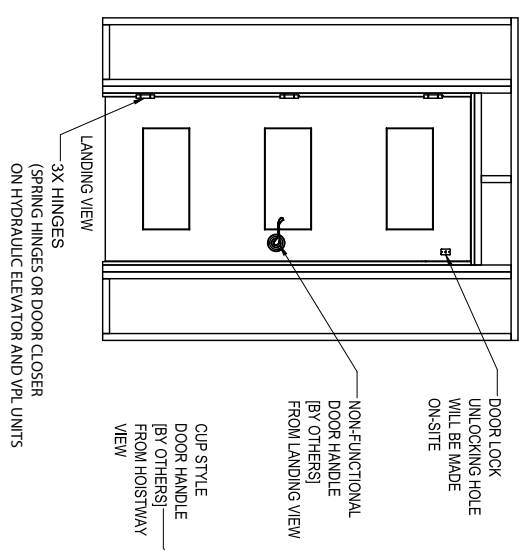

Flush wood door instructions for contractors (cont.)

LOCK CUTOUT DIMENSIONS: FLUSH PORTA LOCK BRACKET

WARNING: Lock cut-out in top corner representative of a standard 80" door.
For taller doors, such as 84" to 96", the top of the cut-out itself needs to stay
at 80" from the ground to allow users access to unlock in case of emergency.

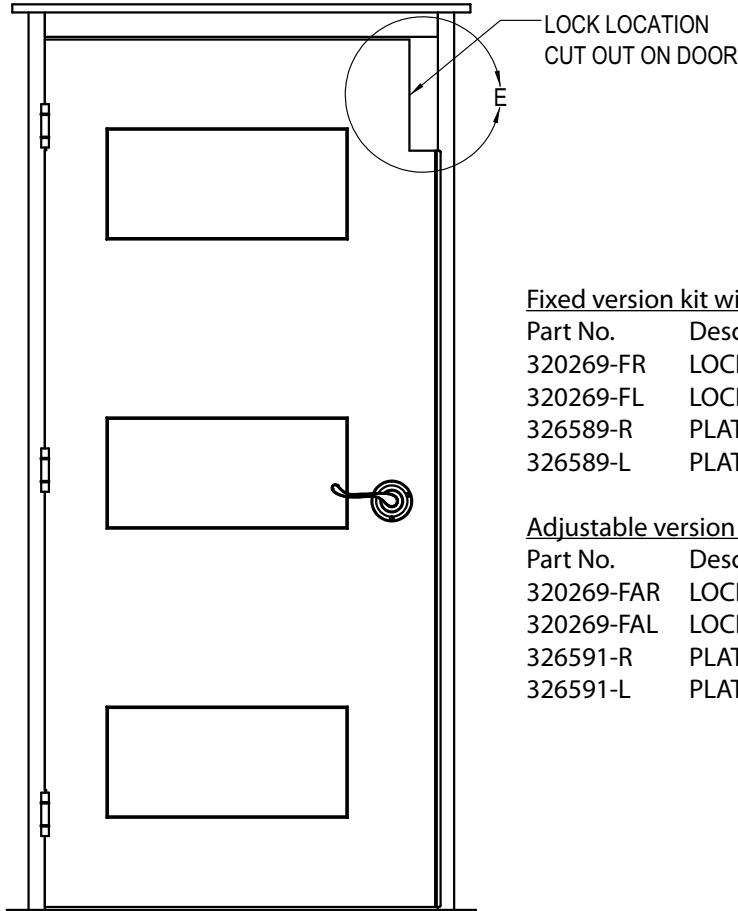

Fixed version kit with lock

Part No.	Description
320269-FR	LOCK_PORTA WOOD DR FLSH, RH ASSY
320269-FL	LOCK_PORTA WOOD DR FLSH, LH ASSY
326589-R	PLATE ONLY, RH
326589-L	PLATE ONLY, LH

Adjustable version kit with lock

Part No.	Description
320269-FAR	LOCK_PORTA WOOD DR FLSH, RH ASSY
320269-FAL	LOCK_PORTA WOOD DR FLSH, LH ASSY
326591-R	PLATE ASSEMBLY ONLY, RH
326591-L	PLATE ASSEMBLY ONLY, LH

LOCK BRACKET OPTIONS:

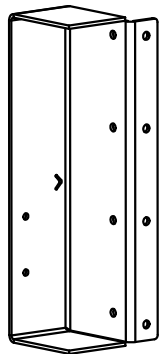

OPTION-1
FOR 1-3/4" DOOR
THICKNESS

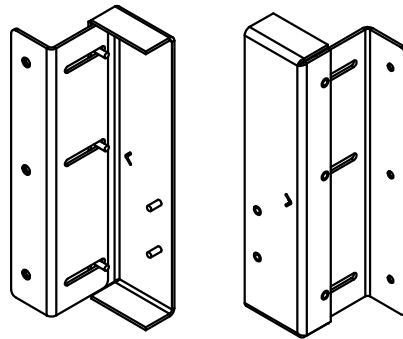

OPTION-2
2 PIECES LOCK
BRACKET FOR 1-1/2" - 2"
DOOR THICKNESS

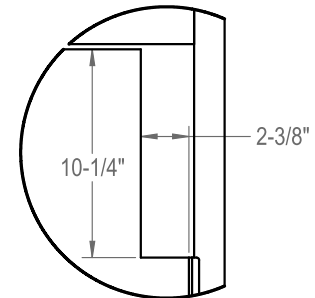

DETAIL E
SCALE 1 : 8

THIS PAGE IS INTENTIONALLY LEFT BLANK

Find more design resources at:

savaria.com

[Online configurator](#)

[CAD drawings](#)

[BIM objects](#)

[SpecWizard](#)

[Continuing education calendar](#)

Savaria Concord Lifts, Inc.

2 Walker Drive Brampton ON L6T 5E1 Canada

*"Serving San Diego and Orange Counties
in Southern California"*

**ADVANTAGE
ELEVATOR**
INCORPORATED

License # C11 1027832

(858) 678-8780

advantageelevator.net



Authorized Savaria Dealer

 **savaria.**

savaria.com

©2023 Savaria Corporation